

KOHLER®

GEN 5.0

Generator Service Manual

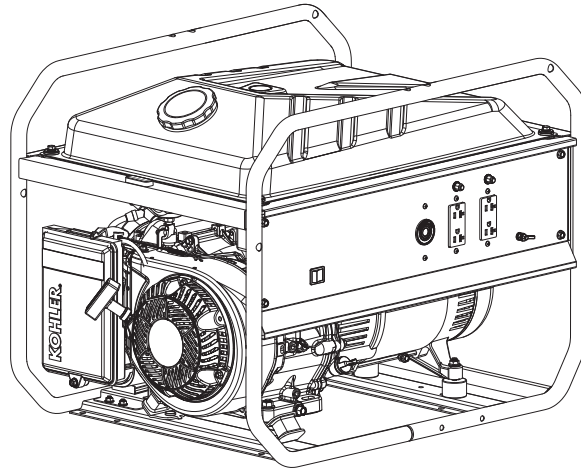

IMPORTANT: Read all safety precautions and instructions carefully before operating equipment.
Ensure equipment is stopped and level before performing any maintenance or service.
For all engine related maintenance, disassembly and reassembly, refer to service manual of engine powering this equipment.

- 2 Safety
- 3 Specifications
- 6 Troubleshooting
- 9 Electrical System
- 10 Disassembly/Inspection and Service
- 12 Reassembly

Safety

SAFETY PRECAUTIONS

- ⚠ DANGER:** A hazard that will result in death, serious injury, or substantial property damage.
- ⚠ WARNING:** A hazard that could result in death, serious injury, or substantial property damage.
- ⚠ CAUTION:** A hazard that could result in minor personal injury or property damage.

NOTE: is used to notify people of important installation, operation, or maintenance information.

	⚠ WARNING
	Explosive Fuel can cause fires and severe burns. Do not fill fuel tank while engine is hot or running.
Gasoline is extremely flammable and its vapors can explode if ignited. Never refuel while smoking or in vicinity of an open flame. Store gasoline only in approved containers, in well ventilated, unoccupied buildings, away from sparks or flames. Spilled fuel could ignite if it comes in contact with hot parts or sparks from ignition. Never use gasoline as a cleaning agent.	





	⚠ WARNING
	Hot Parts can cause severe burns. Do not touch generator while operating or just after stopping.
Never operate generator with heat shields or guards removed. Do not modify generator. Place generator in a place where pedestrians or children are not likely to touch generator. Be sure to carry generator only by its carrying handles.	

	⚠ WARNING
	Rotating Parts can cause severe injury. Stay away while generator is in operation.
Keep hands, feet, hair, and clothing away from all moving parts to prevent injury. Never operate generator with covers, shrouds, or guards removed.	

	⚠ CAUTION
	Hazardous Voltage. Backfeed to utility system can cause property damage, severe injury, or death.
Never plug a portable generator directly into a building outlet. If generator is used for standby power, have a certified, licensed electrician install an automatic transfer switch to prevent inadvertent interconnection of standby and normal sources of supply. There is a permanent conductor between the generator (stator winding) and the frame.	

	⚠ WARNING
	Cleaning Solvents can cause severe injury or death. Use only in well ventilated areas away from ignition sources.
Carburetor cleaners and solvents are extremely flammable. Follow cleaner manufacturer's warnings and instructions on its proper and safe use. Never use gasoline as a cleaning agent.	

	⚠ CAUTION
	Electrical Shock can cause injury. Do not touch wires while generator is running.
Never operate generator in rain or snow. Never touch generator with wet hands or electrical shock may occur.	

⚠ DANGER	
Using a generator indoors CAN KILL YOU IN MINUTES. Generator exhaust contains carbon monoxide. This is a poison you cannot see or smell.	
	
NEVER use inside a home or garage, EVEN IF doors and windows are open.	 
Only use OUTSIDE and far away from windows, door, and vents.	

IDENTIFICATION NUMBERS

Kohler identification numbers (model, specification and serial) should be referenced for efficient repair, ordering correct parts, and engine replacement.

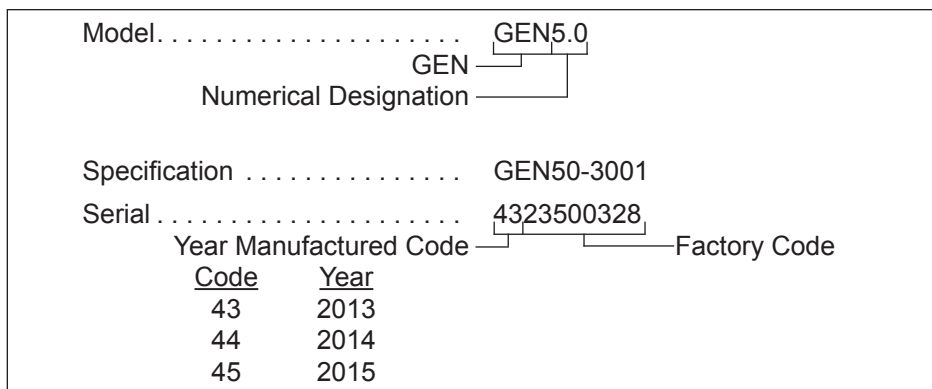

GENERAL SPECIFICATIONS¹

GEN 5.0

Overall Dimensions (L x W x H)	670 mm (26.4 in.) 545 mm (21.5 in.) 535 mm (21.1 in.)
Dry Weight	82 kg (180 lbs.)
AC Rated Power	4300 Watt (120 Volts x 35.8 Amps) (240 Volts x 17.9 Amps)
AC Maximum Power	5000 Watt (120 Volts x 41.7 Amps) (240 Volts x 20.8 Amps)
Fuel Tank	30.2 L (8 gal.)

¹ Values are in Metric units. Values in parentheses are English equivalents.

Specifications



TORQUE SPECIFICATIONS¹

GEN 5.0





Alternator Front Cover	53.5 N·m (474 in. lb.)
Alternator Rear Cover	4.5 N·m (40 in. lb.)
AVR and Brush Assembly	4.0 N·m (35 in. lb.)
Battery Mounting Bracket	
M6 Screws	9.9 N·m (87 in. lb.)
M8 Screws	25.0 N·m (221 in. lb.)
Carbon Canister Mounting Bracket	9.9 N·m (87 in. lb.)
Control Panel Back Cover	5.8 N·m (51 in. lb.)
Control Panel Electrical Components	
M3 Screws	1.3 N·m (11 in. lb.)
M4 Screws	2.9 N·m (26 in. lb.)
Control Panel	9.9 N·m (87 in. lb.)
End Cover	4.0 N·m (35 in. lb.)
Engine/Alternator Rubber Mounts	18.3 N·m (162 in. lb.)
Frame Assembly	
M6 Screws	11.5 N·m (102 in. lb.)
M10 Screws	30.0 N·m (266 in. lb.)
Fuel Tank Mounting	9.9 N·m (87 in. lb.)
Muffler Assembly	
M8 Screws	25.0 N·m (221 in. lb.)
M10 Screws	32.5 N·m (288 in. lb.)
Muffler Cover Assembly	9.9 N·m (87 in. lb.)
Rotor Assembly	22.0 N·m (195 in. lb.)
Stator Assembly	10.4 N·m (92 in. lb.)
Wire Connector	2.5 N·m (22 in. lb.)

¹ Values are in Metric units. Values in parentheses are English equivalents.

GENERAL TORQUE VALUES

English Fastener Torque Recommendations for Standard Applications				
Bolts, Screws, Nuts and Fasteners Assembled Into Cast Iron or Steel				Grade 2 or 5 Fasteners Into Aluminum
Size	 Grade 2	 Grade 5	 Grade 8	
Tightening Torque: N·m (in. lb.) ± 20%				
8-32	2.3 (20)	2.8 (25)	—	2.3 (20)
10-24	3.6 (32)	4.5 (40)	—	3.6 (32)
10-32	3.6 (32)	4.5 (40)	—	—
1/4-20	7.9 (70)	13.0 (115)	18.7 (165)	7.9 (70)
1/4-28	9.6 (85)	15.8 (140)	22.6 (200)	—
5/16-18	17.0 (150)	28.3 (250)	39.6 (350)	17.0 (150)
5/16-24	18.7 (165)	30.5 (270)	—	—
3/8-16	29.4 (260)	—	—	—
3/8-24	33.9 (300)	—	—	—

Tightening Torque: N·m (ft. lb.) ± 20%				
5/16-24	—	—	40.7 (30)	—
3/8-16	—	47.5 (35)	67.8 (50)	—
3/8-24	—	54.2 (40)	81.4 (60)	—
7/16-14	47.5 (35)	74.6 (55)	108.5 (80)	—
7/16-20	61.0 (45)	101.7 (75)	142.5 (105)	—
1/2-13	67.8 (50)	108.5 (80)	155.9 (115)	—
1/2-20	94.9 (70)	142.4 (105)	223.7 (165)	—
9/16-12	101.7 (75)	169.5 (125)	237.3 (175)	—
9/16-18	135.6 (100)	223.7 (165)	311.9 (230)	—
5/8-11	149.5 (110)	244.1 (180)	352.6 (260)	—
5/8-18	189.8 (140)	311.9 (230)	447.5 (330)	—
3/4-10	199.3 (147)	332.2 (245)	474.6 (350)	—
3/4-16	271.2 (200)	440.7 (325)	637.3 (470)	—

Metric Fastener Torque Recommendations for Standard Applications						
Size	Property Class					Noncritical Fasteners Into Aluminum
	 4.8	 5.8	 8.8	 10.9	 12.9	
Tightening Torque: N·m (in. lb.) ± 10%						
M4	1.2 (11)	1.7 (15)	2.9 (26)	4.1 (36)	5.0 (44)	2.0 (18)
M5	2.5 (22)	3.2 (28)	5.8 (51)	8.1 (72)	9.7 (86)	4.0 (35)
M6	4.3 (38)	5.7 (50)	9.9 (88)	14.0 (124)	16.5 (146)	6.8 (60)
M8	10.5 (93)	13.6 (120)	24.4 (216)	33.9 (300)	40.7 (360)	17.0 (150)
Tightening Torque: N·m (ft. lb.) ± 10%						
M10	21.7 (16)	27.1 (20)	47.5 (35)	66.4 (49)	81.4 (60)	33.9 (25)
M12	36.6 (27)	47.5 (35)	82.7 (61)	116.6 (86)	139.7 (103)	61.0 (45)
M14	58.3 (43)	76.4 (56)	131.5 (97)	184.4 (136)	219.7 (162)	94.9 (70)

Torque Conversions	
N·m = in. lb. x 0.113	in. lb. = N·m x 8.85
N·m = ft. lb. x 1.356	ft. lb. = N·m x 0.737

Troubleshooting

TROUBLESHOOTING GUIDE

When troubles occur, be sure to check simple causes which, at first, may seem too obvious to be considered. For example, a starting problem could be caused by an empty fuel tank.

Some general common causes of generator troubles are listed below and vary by specification. Use these to locate causing factors.

Condition	Possible Cause	Solution
No AC output	Circuit breaker in OFF position.	Switch circuit breaker to ON.
	Circuit protector popped out.	Press circuit protectors.
	Engine not operating at rated RPM.	Adjust engine running at normal operating temperature to 3750 ± 100 RPM.
	Circuit breaker or receptacles faulty.	Test for voltage at circuit breaker and receptacles.
	Stator is faulty.	Test for voltage and resistance.
	Brushes are faulty.	Test for resistance between brushes and slip ring.
	AVR is faulty.	Test for voltage.
Low voltage at stator	Field polarity was lost.	Flash rotor field.
Alternator can't output rated power	Engine not operating at rated RPM.	Adjust engine running at normal operating temperature to 3750 ± 100 RPM.
	Overload condition.	Calculate electrical power required by electric appliances (in Watts). Reduce total wattage of connected electric devices within application range.
	Appliance is faulty.	Repair faulty appliance.

Tests

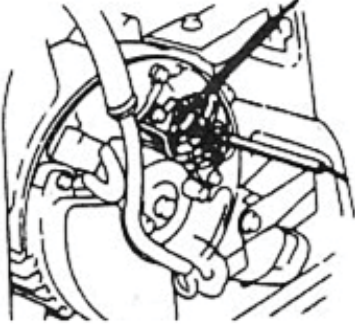
Stator voltage		Remove rear cover and start engine with no load. Check if stator terminals have correct voltage.
----------------	---	--

Troubleshooting

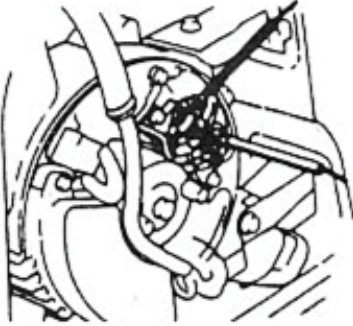
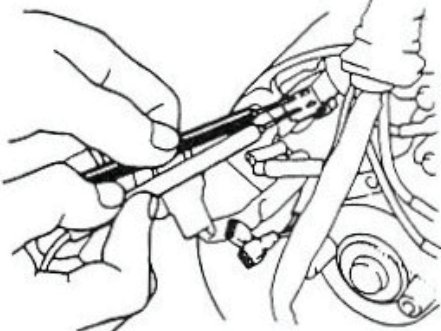
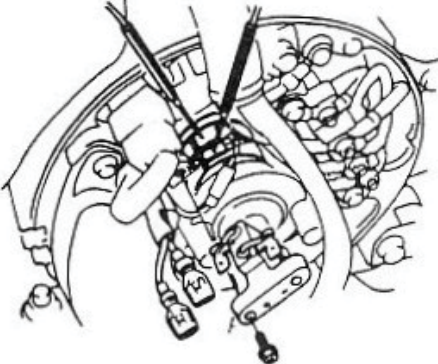
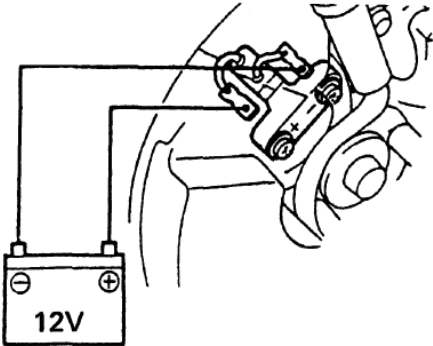
Stator resistance		<p>With engine stopped, check main coil stator winding resistance between wires with ohmmeter or circuit tester. Replace if out of specification.</p>
		<p>With engine stopped, check exciting coil stator winding resistance between wires with ohmmeter or circuit tester. Replace if out of specification.</p>
Brush resistance		<p>With engine stopped, remove brush. Check brush and slip ring of rotor for resistance. Replace if out of specification.</p>
Flashing Field		<p>With engine stopped, momentarily touch brush terminals with leads from a good 12 volt battery.</p>

Troubleshooting

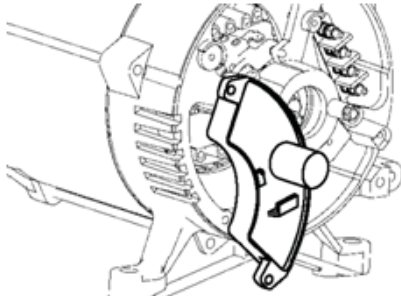
Replace AVR		<p>With engine stopped, replace AVR with a new AVR. Start engine and adjust trimmer on back of AVR. Test terminal voltage. Voltage should be between 95-135V. If voltage is met, original AVR is not adjusted properly or faulty. Replace as necessary. If voltage not met, check circuit breakers and receptacles.</p>
-------------	---	---

Unit	Item	Generator Spec.			REMARK
		GEN 5.0	PRO5.2/5.2E	PRO7.5/7.5E	
Main Winding	Red-Blue	0.37Ω±10%	0.27Ω±10%	0.13Ω±10%	Red-White (PRO 7.5 E)
	White-Black	0.37Ω±10%	0.27Ω±10%	0.13Ω±10%	
Field Winding	Between slip ring	47.9Ω±10%	46.6Ω±10%	56.4Ω±10%	
Exciter Winding	Blue-Blue	1.30Ω±10%	1.60Ω±10%	1.02Ω±10%	
DC Winding	Orange-Orange	-	0.10Ω±10%	0.08Ω±10%	
Brush	Length	9mm			Service limit: 5mm

NOTE: Alternator should not be in contact with panel, AVR, etc during above resistance tests. Alternator should be tested at room temperature.

GEN 5.0 Wiring Diagram

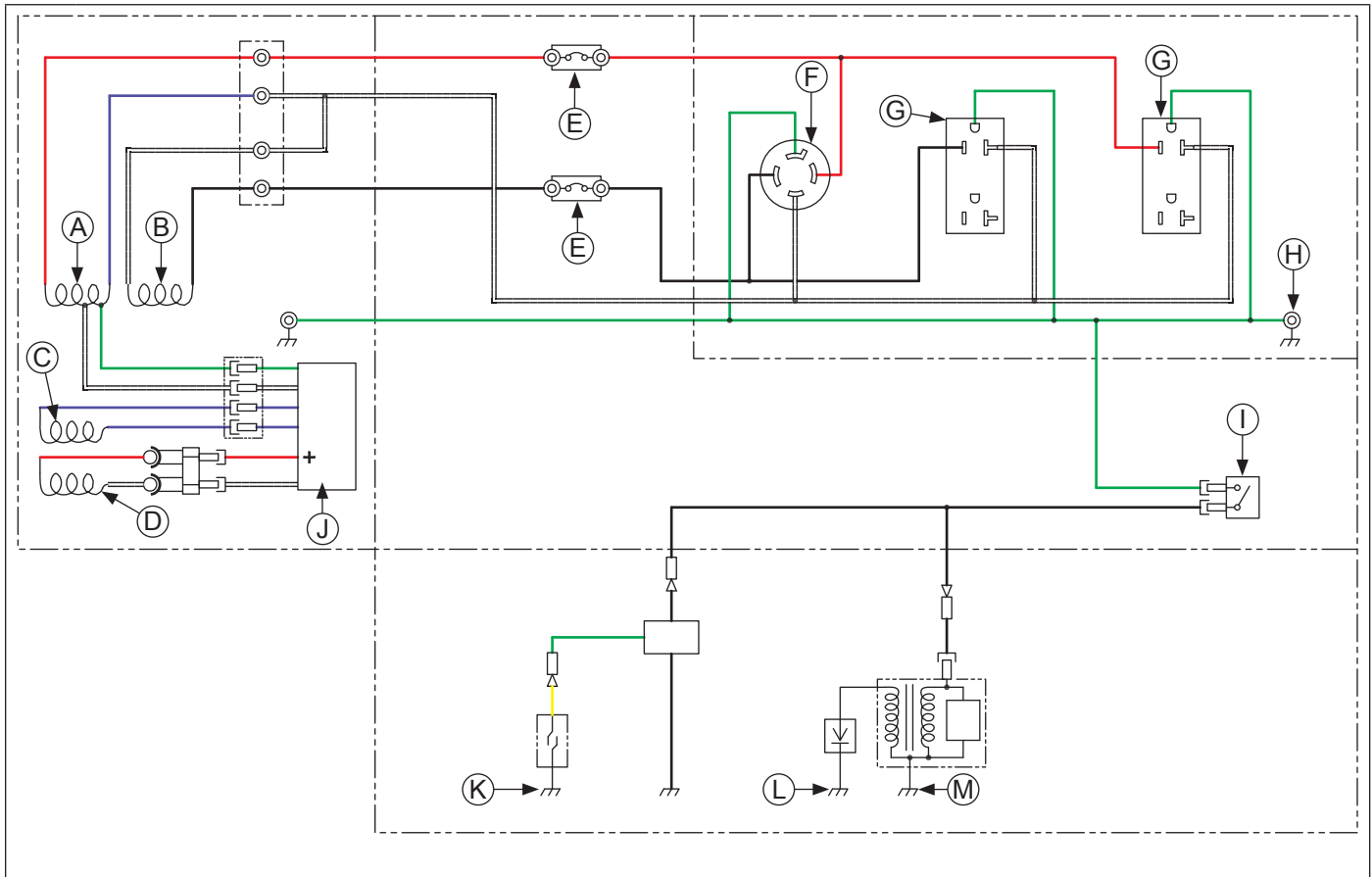

A	Main Winding 1	B	Main Winding 2	C	Exciter Field Coil	D	Sub Coil
E	Circuit Protector 20A	F	240/120V/20A Electrical Socket	G	120V/20A Receptacle	H	Ground Terminal
I	On/Off Switch	J	AVR	K	Oil Float Switch	L	Spark Plug
M	Ignition Module						

⚠ CAUTION

Electrical Shock can cause injury.
Do not touch wires while engine is running.

Check Control Panel

Remove control panel from frame. Remove control box from control panel and check each components and wiring.

Disassembly

1. Remove the end cover and disconnect wire terminals from wiring board.
2. Remove control panel.
3. After disconnecting individual wires, remove control panel components.

Reassembly

NOTE: Circuit diagrams provide colored wires used for easy identification. To replace wires, use heat-resistant type wires (permissible temperature range 75°C (167°F) or over) and same gauge of wire that is removed.

1. Install receptacles, circuit breakers, sockets, switches, etc. on control panel.
2. Connect wires to control panel components.
3. Assemble wire terminals to wiring board.
4. Assemble end cover to rear cover. Torque screws to 4 N·m (35 in. lb.).
5. Attach control panel and control box to frame.

Disassembly/Inspection and Service

GEN 5.0 Components

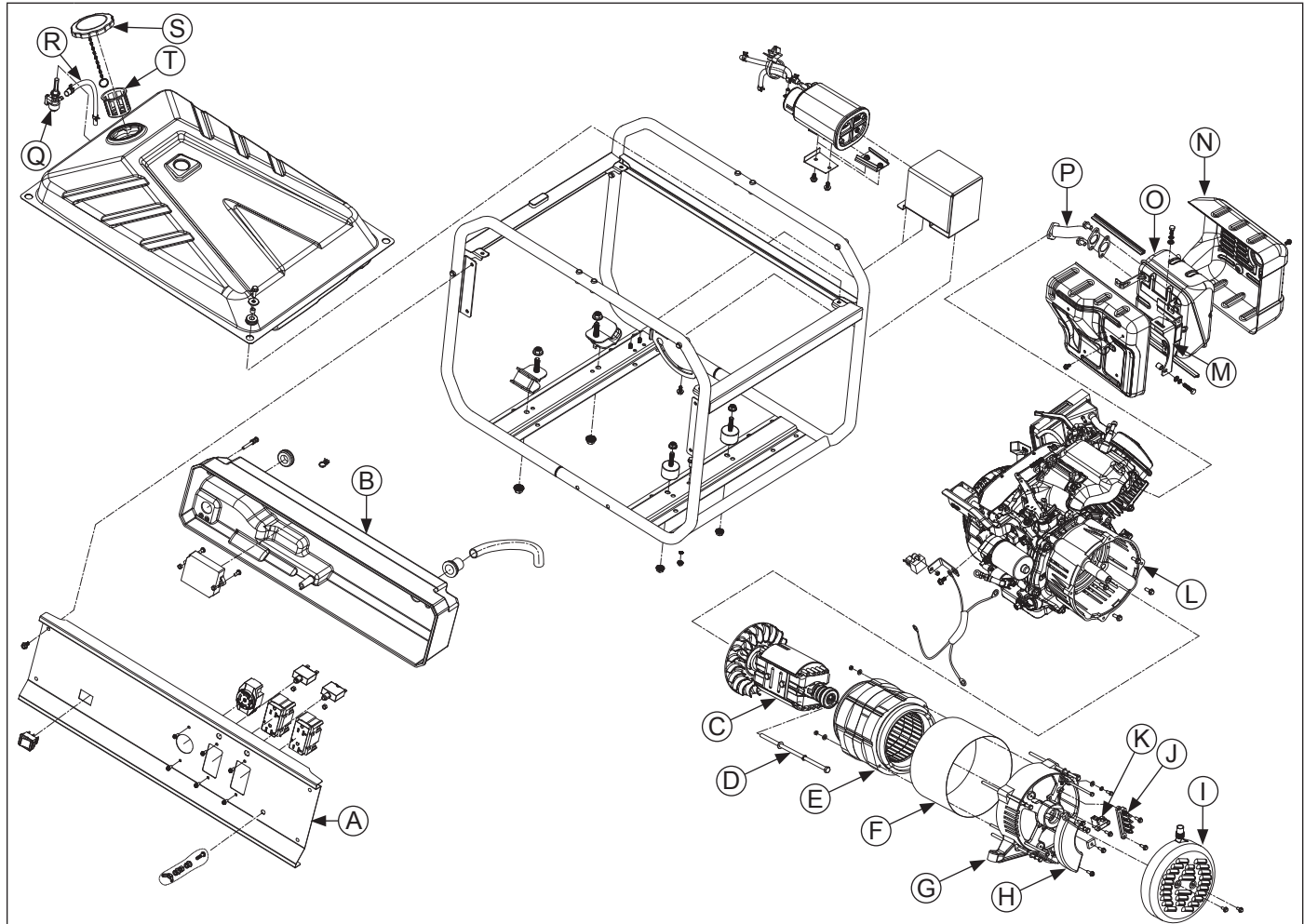

A	Control Panel	B	Control Box	C	Rotor	D	Through Bolt
E	Stator	F	Stator Cover	G	Rear Cover	H	AVR
I	End Cover	J	Wiring Board	K	Brush Holder	L	Front Cover
M	Muffler Bracket	N	Muffler Cover	O	Muffler	P	Exhaust Pipe
Q	Fuel Valve	R	Fuel Hose	S	Fuel Tank Cap	T	Fuel Filter

Disassembly/Inspection and Service

Be sure to memorize location of individual parts when disassembling generator so that generator can be reassembled correctly. Tag disassembled part with necessary information to facilitate easier and smoother reassembly.

For more convenience, divide parts into several groups and store them in boxes.

To prevent screws from being misplaced or installed incorrectly, replace them temporarily to their original position.

Handle disassembled parts with care; clean them before reassembly using a neutral cleaning fluid.

Be sure to attach foam rubber linings inside covers on their original position when reassembling generator. When deformation or damage of foam rubber lining is found, replace it with new part. Failure to do so will result in poor performance and durability of generator.

Tie wires and fuel hoses using cable ties as they were in original configuration.

Remove Fuel Tank

1. Close fuel valve and remove fuel hose from carburetor. Drain fuel into an approved container.
2. Disconnect fuel hose from fuel valve.
3. Remove screws from fuel tank and remove fuel tank.

Remove Muffler

1. Remove screws securing muffler cover and muffler cover.
2. Remove screws for muffler bracket.
3. Remove screws securing exhaust pipe to engine and remove muffler.

Remove Control Panel



CAUTION

Electrical Shock can cause injury.
Do not touch wires while engine is running.

NOTE: When removing wiring terminals from wiring board, it may be helpful to document order.

1. Remove end cover.
2. Disconnect wire connections from alternator.
3. Remove wiring terminals from wiring board.
4. Disconnect wiring from control panel to engine.
5. Remove screws securing control panel to frame.
6. To access inside control panel, remove screws securing control box to control panel.

Remove AVR

Remove screws attaching AVR to rear cover and remove AVR unit.

Remove Brush Holder

Remove screw attaching brush holder to rear cover and remove brush holder.

Inspection

1. Inspect brushes for freedom of movement in brush holder.
2. Check continuity between each brush tip and its wire terminal.
3. Inspect brush-to-rotor contact surface for unusual wear or contamination.
4. Check brush free length. Replace brush assembly if length is less than 3/16 in. (5 mm).

Remove Stator

NOTE: Take care not to damage stator coil and rotor coil when removing/installing them.

NOTE: Place stator core side down. Do not set stator on coil end. Coils may be damaged.

NOTE: It may be easier in some instances to tip generator set on a side. Ensure oil is drained from engine prior to doing this.

NOTE: Rear cover and stator are screwed together. Do not loosen or remove screws. Remove rear cover from stator after separated from alternator.

NOTE: Stator is heavy; be prepared to handle weight to maneuver for inspection and service.

1. Remove nuts fixing rear cover onto rubber mounts.
2. Remove stator.
 - a. Remove stator and rear cover as an assembly.
 - b. Remove screws connecting rear cover and stator.
3. Remove rear cover.

Remove Rotor

1. Remove through bolt of rotor.
2. Place a wooden block or similar material under rotor to support weight as rotor is removed.
3. With a rubber mallet, tap rotor a few times. Rotor should slide off engine shaft.

Remove Front Cover

Remove screws and washers securing front cover and remove front cover.

Reassembly

GEN 5.0 Components

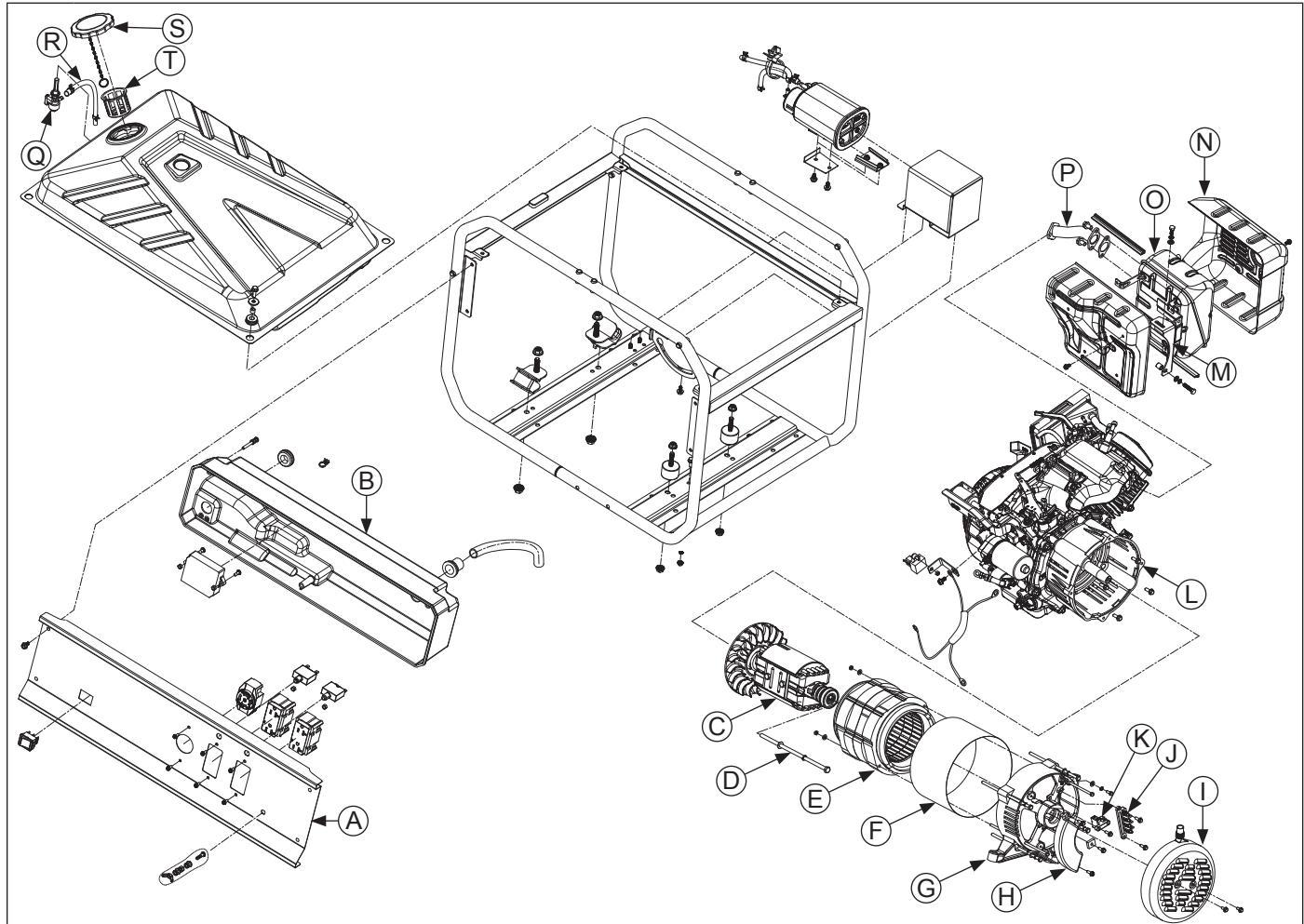

A	Control Panel	B	Control Box	C	Rotor	D	Through Bolt
E	Stator	F	Stator Cover	G	Rear Cover	H	AVR
I	End Cover	J	Wiring Board	K	Brush Holder	L	Front Cover
M	Muffler Bracket	N	Muffler Cover	O	Muffler	P	Exhaust Pipe
Q	Fuel Valve	R	Fuel Hose	S	Fuel Tank Cap	T	Fuel Filter

Install Front Cover

Attach front cover to engine main bearing cover. Torque to 53.5 N·m (474 in. lb.).

Install Rotor

NOTE: Before installing rotor make sure crankshaft taper and rotor are clean, dry, and completely free of any lubricants. Presence of lubricants can cause rotor to be over stressed and damaged when screw is torqued to specifications.

Mount rotor to engine shaft. Tighten through bolt.

Install Stator

1. Assemble rear cover to stator and pull out stator wire harness through opening of rear cover.
2. Torque stator and rear cover screws to 10.4 N·m (92 in. lb.).
3. Press stator with rear cover evenly onto rotor. Tap with a rubber mallet to ensure rotor bearing is pressed into rear cover.
4. Tighten rear cover screws to front cover. Torque to 4.5 N·m (40 in. lb.).
5. Set rubber mount screws into rear cover. Do not tighten nuts at this moment.

Install Brush Holder

NOTE: Install brush holder evenly onto rear cover using locating pin. If set incorrectly, damage may occur when tightened with screw or when generator is started.

Install brush holder. Torque screw to 4 N·m (35 in. lb.).

Install AVR

Attach connectors to brush holder, AVR unit. Torque screws to 4 N·m (35 in. lb.).

Install End Cover

1. Tighten earth (ground) wire (green) to rear cover with screw and washer.
2. Assemble earth (ground) wire between frame and rear cover rubber mount. Torque nuts to 18.3 N·m (162 in. lb.).
3. Assemble wire terminals to wiring board .
4. Assemble end cover to rear cover. Torque screws to 4 N·m (35 in. lb.).

Install Muffler

1. Assemble muffler pipe and gasket to engine exhaust and snug screws.
2. Assemble muffler bracket to rear cover and snug screws.
3. Torque M8 screws to 25 N·m (221 in. lb.) and M10 screws to 32.5 N·m (288 in. lb.).
4. Attach muffler cover to muffler. Torque screws to 9.9 N·m (87 in. lb.).

Install Control Panel

Place control panel onto frame. Torque screws to 9.9 N·m (87 in. lb.).

Install Fuel Tank

1. Mount fuel tank on frame. Torque nuts to 9.9 N·m (87 in. lb.).
2. Replace fuel hose to fuel valve.

Generator is now completely reassembled. Before starting or operating engine, be sure to follow steps below.

1. Make sure all hardware is tightened securely.
2. Turn on fuel supply.
3. Replace battery (if equipped).
4. Start generator following starting instructions.
5. Check for proper voltage at receptacles.



1P37 690 02



8 85612 30290 8