

Service

PSI Emission Certified Engine
Envirotec 1600

Generator Models:
10-30 kW

CAUTION

Caution: In order to reduce the chance of personal injury and/or property damage, carefully observe the instructions that follow.

This service manual is intended for use by professional, qualified technicians. Attempting repairs or service without the appropriate training, tools, and equipment could cause injury to you or others, damage the equipment, or cause the equipment to operate improperly.

Proper equipment and repair are important to the safety of the service technician and to the safe, reliable operation of the equipment. If you need to replace a part, use the same part number or an equivalent part. Do not use a replacement part of lesser quality.

The service procedures we recommend and describe in this service manual are effective methods of performing service and repair. Some of the procedures require the use of tools that are designed for specific purposes.

Accordingly, any person who intends to use a replacement part, a service procedure, or a tool that is not recommended by the generator set manufacturer must first establish that there is no jeopardy to personal safety or the safe operation of the equipment.

This manual contains various *Cautions* and *Notices* that you must observe carefully to reduce the risk of personal injury during service or repair. Improper service or repair may damage the equipment or render the equipment unsafe. These *Cautions* and *Notices* are not exhaustive. The generator set manufacturer cannot possibly warn of all the potentially hazardous consequences of failure to follow these instructions.

Table of Contents

Caution	Inside Front Cover
Introduction	i
Cautions and Notices	l
Section 0B Maintenance	OB-1
Section 1A1 LPG Vapor Fuel System Operation	1A1-1
Section 1A2 Gasoline Vapor Fuel System Operation	1A2-1
Section 1B1 LPG System Diagnosis	1B1-1
Section 1B2 Gasoline System Diagnosis	1B2-1
Section 1C2 Engine Control System Electrical	1C2-1
Section 1C4 Diagnostic Trouble Codes	1BC-1
Section 2A1 Base Engine Repair	2A1-1

This service manual provides the service technician with information to service the Envirotec 1600 engine.

In general, this manual covers the service of the engine and associated standard equipment. In some cases the engine is supplied with accessories and equipment that are unique to the application. If service information is required on such unique accessories or equipment, contact the generator set manufacturer who will forward the proper information or advise the service technician where it can be obtained.

The information in this manual is grouped in sections according to the type of work being performed. The various sections are indicated in the Table of Contents of the manual.

This manual has been reprinted by the generator set manufacturer with the permission of Power Solutions, Inc.

This manual is a reproduction of a Power Solutions, Inc. publication and contains information pertaining to generator set engines. Some information pertains to other applications of the engine. The accuracy and completeness of information is the sole responsibility of Power Solutions, Inc.

The descriptions and specifications contained in this manual were in effect at the time the book was released by Power Solutions, Inc.. The generator set manufacturer and Power Solutions, Inc. reserve the right to discontinue models or change specs or design at any time without notice and without incurring obligation.

Notes

Definition of Caution, Notice, and Important

The diagnosis and repair procedures in the GM Powertrain Service Manual contain both general and specific Cautions, Notices, and Important. GM Powertrain is dedicated to the presentation of service information that helps the technician diagnose and repair the systems necessary for the proper operation of the equipment; however, certain procedures may present a hazard to the technician if they are not followed in the recommended manner. Cautions, Notices, and Important are elements designed to prevent these hazards; however, not all hazards can be foreseen. This information is placed at strategic locations within the service manual and is designed to prevent the following:

- Serious bodily injury to the technician.
- Damage to the equipment.
- Unnecessary equipment repairs.
- Unnecessary component repairs.
- Improper repair or replacement equipment components. Any caution or notice that appears in general information is referenced from the individual service categories.

Caution Defined

When encountering a Caution, you will be asked to take a necessary action or avoid a prohibited action. Cautions are designed to prevent:

- Serious bodily injury to the technician.
- Serious bodily injury to other technicians in the workplace area.
- Serious bodily injury to the equipment operator if the equipment has been improperly repaired.

Notice Defined

Notices call special attention to a necessary action or to a prohibited action. Notices are designed to prevent:

- Damage to the equipment.
- Unnecessary equipment repairs.
- Unnecessary component replacement.
- Improper operation or performance of the system or component under repair.
- Damage to any systems or components that are dependent upon the proper operation of the system or component under repair.
- Improper operation or performance of any systems or components that are dependent upon the proper operation or performance of the system or component under repair.
- Damage to fasteners, basic tools, or special tools.
- Leaks of coolant, lubricant, or other vital fluids.

Important Defined

Important statements emphasize a necessary characteristic of a diagnostic or repair procedure. *Important* statements are designed to do the following:

- Clarify a procedure.
- Present additional information for accomplishing a procedure.
- Give insight into the reason or reasons for performing a procedure in the manner recommended.
- Present information that will help to accomplish a procedure in a more effective manner.
- Present information that gives the technician the benefit of past experience in accomplishing a procedure with greater ease.

Moving Parts and Hot Surfaces Caution

Caution: Avoid contact with moving parts and hot surfaces while working around a running engine in order to prevent physical injury.

Safety Glasses Caution

Caution: Always wear safety glasses to avoid eye damage.

Belt Drive Notice

Notice: Do not use belt dressing on the drive belt. Belt dressing causes the breakdown of the composition of the drive belt. Failure to follow this recommendation will damage the drive belt.

Component Fastener Tightening Notice

Notice: Replacement components must be the correct parts for the application. The service procedure identifies components requiring the use of the thread-locking compound, lubricants, corrosion inhibitors, or sealants. Some replacement components may come with these coatings already applied. Do not use these coatings on components unless specified. These coatings can affect the final torque, which may affect the operation of the component. Use the correct torque specifications when installing components in order to avoid damage.

Fastener Notice

Notice: Use the correct fastener in the correct location. Replacement fasteners must be the correct parts for that application. The service procedure identifies fasteners requiring replacement or fasteners requiring the use of thread-locking compound or sealant. Do not use paints, lubricants, or corrosion inhibitors on fasteners or fastener joint surfaces unless specified. These coatings affect fastener torque and joint clamping force and may damage the fastener. Use the correct tightening sequence and specifications when installing fasteners in order to avoid damage to parts and systems.

Special Fastener Notice

Notice: This bolt is designed to permanently stretch when tightened. The correct fastener must be used to replace this type of fastener. Do not use a bolt that is stronger than the original in this application. If the correct bolt is not used, the parts will not be tightened correctly. The system or the components may be damaged.

SECTION OB

MAINTENANCE

Maintenance	0B-2
Checking Coolant Level	0B-2
Engine Electrical System.....	0B-3
Checking/Changing Oil	0B-3 & 4
Exhaust System Maintenance	0B-5
Fuel System Inspection & Maintenance	0B-5 & 6
Maintenance Chart	0B-7

GENERAL

This engine is emission certified to meet specific regulation requirements. It is the equipment owner's responsibility to insure that the engine is maintained to the recommendations contained in this manual. Failure to maintain the engine properly can void the engine's warranty. In addition, the engine's fuel and control system components are serviced as assemblies only. Rebuilding or repairing engine fuel system components is not authorized and will void the engine's warranty. Contact the equipment manufacturer with any questions.

MAINTENANCE

The maintenance of the engine and its related components is critical to the life of the engine and optimum performance during its useful life. All engines require a certain amount of maintenance. The suggested maintenance requirements are contained in this section. Industrial engines operate in various environments from extremely dusty environments, to hot and

WARNING

When performing maintenance on the engine, shut off the engine and disconnect the battery negative cable to avoid injury or damage to the engine.

cold temperature environments and clean environments. The recommended schedule is a recommended guide line for the owner and servicing agency to follow, however certain environmental operating conditions may require more frequent inspection and maintenance. In addition the owner may have installed additional equipment to the equipment which may also increase the requirements for service on certain components. Therefore the owner and servicing agent should review the operating condition of the equipment and determine if more frequent inspections and maintenance cycles maybe required.

The engine installed in this equipment may use one or both accessory drive belt configurations. The drive belt may be incorporated to drive the water pump, alternator and additional pumps or devices. It is important to note, the drive belt may be an integral part of the cooling and charging system and should be inspected at a minimum according to the maintenance schedule in this section and in extremely hot and dirty environments more often.

When inspecting the belts check for:

- Cracks,
- Chunking of the belt,
- Splits
- Material hanging loose from the belt
- Glazing, hardening

If any of these conditions exist the belt should be replaced with an OEM replacement belt.

V-BELT SYSTEMS

Check the belt tension by pressing down on the midway point of the longest stretch between two pulleys. The belt should not depress beyond 13mm (1/2 inch). If the depression is more than allowable adjust the tension. Do not over tighten the tension of the belt. Over tightening may cause overload on the bearings and pulleys of the drive belt components.

SERPENTINE BELT SYSTEM

Serpentine belts utilize a spring-loaded tensioner which keeps the belt properly adjusted. Serpentine belts should be checked according to the maintenance schedule in this section.

IMPORTANT:

The engine manufacturer does not recommend the use of “belt dressing” or “anti slipping agents” on either belt configuration.

COOLING SYSTEM

It is important to remember that the cooling system of this engine be maintained properly to insure the longevity of the engine. Maintenance of the cooling system is critical to the engine. Therefore proper maintenance of the cooling system should include removing dust, dirt and debris from the radiator core on regular intervals. To properly maintain the cooling system follow the recommend maintenance schedule in this section.

Cooling system inspections should be performed as prescribed when inspecting the cooling system check for the following:

- Plugged or restricted radiator core clean with compressed air, blow dust and debris from the core and the fan shroud
- Check the radiator cap to insure proper sealing if damage replace
- Check for coolant leaks at the radiator tank seams and inlet joints repair or replace as necessary
- Check for leaks at the radiator hose connections, tighten hose clamps if necessary
- Check Radiator hoses for swelling, separation, cracks deterioration in the hoses, or hardening, if any of these conditions exist the hose should be replaced with the OEM replacement parts
- Check coolant level if low add with 50/50 mixture, Do not add plain water
- Replace coolant per the recommended schedule at the end of this section

CHECKING THE COOLANT LEVEL

1. Check coolant level in coolant recovery tank. Add specified coolant as required.

WARNING

Do not remove the cooling system pressure cap when the engine is hot. Allow the engine to cool and then remove the cap slowly allowing pressure to vent. Hot coolant under pressure may discharge violently

IMPORTANT:

The engine manufacturer and the fuel system supplier do not recommend the use of “stop leak” additives to repair leaks in the cooling system. If leaks are present the radiator should be removed and repaired.

If the radiator requires repair insure that the radiator core repairs did not result in a significant reduction in the cooling capacity of the radiator.

The engine manufacturer recommends the cooling system be filled with a 50/50 mixture of antifreeze and water. The use of DwxCool “Long Life” type coolant (orange) is required. The use of ethylene glycol based coolant (green) may contribute to premature wear of seals and moving parts in the engine’s cooling system.

ENGINE ELECTRICAL SYSTEM MAINTENANCE

The engine electrical system incorporates computers to control certain functions of the equipment. The electrical system connections and ground circuits require good connections. Follow the recommended maintenance schedule in this section to maintain optimum performance. When inspecting the electrical system check the following:

- Check battery connection clean and insure that connectors are tight.
- Check battery for cracks or damage to the case replace if necessary.
- Check Positive and Negative cables for corrosion, rubbing, chaffing and insure tight connections at both ends.
- Check engine wire harness for rubbing, chaffing, pinching, and cracks or breaks in the wiring.
- Check engine harness connectors, check to insure fitted and locked by pushing the connector together then pull on the connector halves to insure they are locked.
- Check ignition coil wire for hardening, cracking, arcing, chaffing, separation, split boot covers and proper fit.
- Check spark plug wires for hardening, cracking, chaffing, separation, split boot covers and proper

fit.

- Replace spark plugs at the required intervals per the recommended maintenance schedule
- Check to insure all electrical components are securely mounted and retained to the engine or chassis.
- Check to insure any additional electrical devices installed by the owner are properly installed in the system.
- Check the MIL, charging, and oil pressure lights for operation by starting the engine and checking that the light illuminates for the prescribe period of time before turning out.

ENGINE CRANKCASE OIL

OIL RECOMMENDATION

To achieve proper engine performance and durability, it is important that you use only engine lubricating oils of the correct quality in your engine. Proper quality oils also provide maximum efficiency for crankcase ventilation systems, which reduces pollution.

Important: use only engine oils displaying the American Petroleum Institute (API) “Starburst” Certification Mark ‘FOR GASOLINE ENGINES’ on the container.



Gasoline engines that are converted for LPG or NG fuels MUST use oils labeled ‘FOR GASOLINE ENGINES’. Do not use oils that are specifically formulated for Diesel Engines only. CC or CD classification oils, even when labeled Heavy Duty or for Natural Gas Engines, ARE NOT ACCEPTABLE.

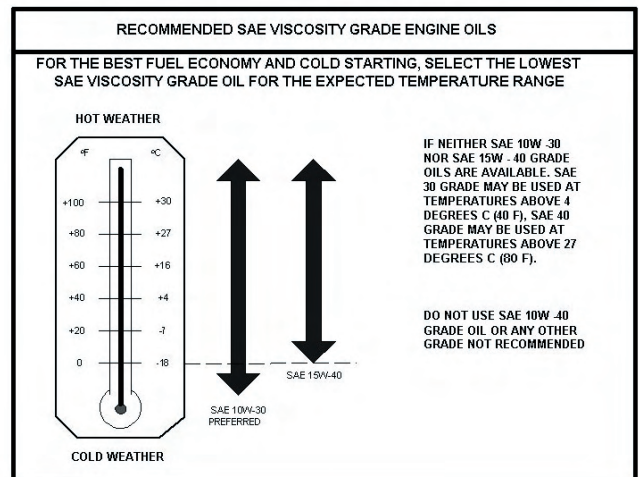

Figure 1 Engine Oil Viscosity Recommendation

USE OF SUPPLEMENTAL ADDITIVES

Use of the oils recommended by the engine manufacturer already contains a balanced additive treatment. The uses of supplemental additives which are added to the engine oil by the customer are not necessary and may be harmful. The engine manufacturer does not review, approve or recommend such products.

SYNTHETIC OILS

Synthetic oils have been available for use in industrial engines for a relatively long period of time. Synthetic oils may offer advantages in cold temperature pumpability and high temperature oxidations resistance. However, synthetic oils have not proven to provide operational or economic benefits over conventional petroleum-based oils in industrial engines. Their use does not permit the extension of oil change intervals.

CHECKING/FILLING ENGINE OIL LEVEL

IMPORTANT; Care must be taken when checking engine oil level. Oil level must be maintained between the “ADD” mark and the “FULL” mark on the dipstick. To ensure that you are not getting a false reading, make sure the following steps are taken before checking the oil level.

1. Stop engine if in use
2. Allow sufficient time (approximately 5 minutes) for the oil to drain back into the oil pan
3. Remove the dipstick. Wipe with a clean cloth or paper towel and reinstall. Push the dipstick all the way into the dipstick tube.
4. Remove the dipstick and note the oil level.
5. Oil level must be between the “FULL” and “ADD” marks.

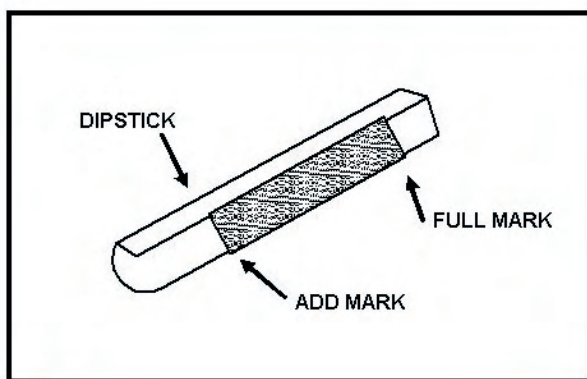

Figure 2 Engine Oil Dip stick (Typical)

6. If the oil level is below the “ADD” mark, proceed to Step 7 and 8, and reinstall the dipstick into the dipstick tube.
7. Remove the oil filler cap from the valve rocker arm cover
8. Add the required amount of oil to bring the level up to but not over the “FULL” mark on the dipstick

9. Reinstall the oil filler cap to the valve rocker arm cover



CAUTION

Overfilled crankcase (oil level being too high) can cause an oil leak, a fluctuation or drop in the oil pressure and rocker arm “clatter” on engines. The overfill condition results in the engine crankshaft splashing and agitating the oil, causing it to foam (become aereated). The aereated oil causes the hydraulic lifters to “bleed down”. This results in rocker arm clatter and loss of engine performance due to valves not opening properly.

and wipe any excess oil clean.\

CHANGING THE ENGINE OIL

IMPORTANT: When changing the oil, always change the oil filter.

1. Start the engine and run until it reaches normal operating temperature.

IMPORTANT: Change oil when engine is warm from operation as it flows more freely, carrying away more impurities.

2. Stop engine.

IMPORTANT: Engine oil will be hot. Use protective gloves to prevent burns. Engine oil contains chemicals which may be harmful to your health avoid skin contact.

3. Remove drain plug and allow the oil to drain.
4. Remove and discard oil filter and its sealing ring.
5. Coat sealing ring on the new filter with clean engine oil, wipe the sealing surface on the filter mounting surface to remove any dust, dirt or debris. Tighten filter securely (follow filter manufacturer's instructions). Do not over-tighten.
6. Check sealing ring on drain plug for any damage, replace if necessary, wipe plug with clean rag, wipe pan sealing surface with clean rag and re-install plug into the pan. Tighten to specification.
7. Fill crankcase with oil.
8. Start engine and check for oil leaks.
9. Dispose of oil and filter in a safe manner.

AIR FUEL MIXER/THROTTLE CONTROL DEVICE MAINTENANCE AND INSPECTION

IMPORTANT: The Air Fuel Mixer components have been specifically designed and calibrated to meet the fuel system requirements of the emission certified engine. The mixer should not be disassembled or rebuilt. If the mixer fails to operate or develops a leak the mixer should be replaced with the OEM recommended replacement parts.

When inspecting the mixer check for the following items:

- Check for any fuel leaks at the inlet fitting.
- Check the fuel inlet hose for cracking, splitting or chaffing, replace if any of these condition exist.
- Check to ensure the mixer is securely mounted.
- Check air inlet hose connection and insure clamp is tight, check inlet hose for cracking, splitting or chaffing, replace if any of these condition exist.
- Check air cleaner element according to the *Recommended Maintenance Schedule* found in this section.

EXHAUST SYSTEM INSPECTION AND MAINTENANCE

IMPORTANT: The exhaust system on this emission certified engine contains an Exhaust Gas Oxygen Sensor (EGO) which provides feed back to the ECM on the amount of oxygen present in the exhaust stream after combustion. The measurement of oxygen in the exhaust stream is measured in voltage and sent to the ECM. The ECM then makes corrections to the fuel air ratio to ensure the proper fuel charge and optimum catalytic performance. Therefore it is important that the exhaust connections remain secured and air tight.

IMPORTANT: The EGO sensor is sensitive to silicone or silicone based products. Do not use silicone sprays or hoses which are assembled using silicone lubricants. Silicone contamination can cause severe damage to the EGO.

When inspecting the Exhaust system check the following:

- Check the exhaust manifold at the cylinder head for leaks and that all retain bolts and shields (if used) are in place.
- Check the manifold to exhaust pipe fasteners to ensure they are tight and that there are no exhaust leaks repair if necessary.
- Check EGO electrical connector to ensure connector is seated and locked, check wires to ensure there is no cracking, splits chaffing or “burn through” repair if necessary.

- Check any exhaust pipe extension connector for leaks tighten if necessary
- Visually inspect to insure muffler is securely mounted and tail pipe is properly aimed.
- Check for any leaks at the inlet and outlet of the muffler.

GASOLINE FUEL SYSTEM

FUEL TANK MAINTENANCE AND INSPECTION

The gasoline fuel tank is integrated into the equipment by the OEM. Gasoline is stored as a liquid in the fuel tank and is drawn from the fuel tank through a pick-up tube by an externally mounted 12 volt electric fuel pump.

When inspecting the fuel tank check the following;

- Check for leaks in the tank.
- Check the fill cap sealing ring for cracks, chunking, separation replace if any of these conditions exist.
- Check the fill cap for cracks check threads for burrs and distortion ensure cap is tight.
- Check outlet hose fitting and connection ensure tight seal.
- Check fuel return line connection and fittings for leaks.
- Check fuel return line for cracking, chaffing, separation replace if any of these conditions exist.

GASOLINE FUEL FILTER INSPECTION AND REPLACEMENT

The gasoline fuel system incorporates an inlet replaceable fuel filter to remove dirt, debris and contaminants which may have been introduced into the fuel tank. Replace the filter as prescribed in the Recommended Maintenance Schedule found in this section.

When inspecting the gasoline fuel filter check the following;

- Check for leaks at the inlet and outlet connections of the filter.
- Check to ensure the gasoline fuel filter is securely mounted.
- Check for any damage to the filter.

To replace the Gasoline fuel filter use the following steps:

1. Move the forklift to a well ventilated area and insure all external ignition sources are not present.
2. Place a drain receptacle under the forklift to capture any fuel which may drain from the lines.
3. Shut OFF the engine.
4. Disconnect the fuel inlet fitting.
5. Disconnect the fuel outlet fitting.
6. Remove the gasoline fuel filter from the mounting bracket
7. Discard the filter in a safe and proper manner
8. Reinstall the fuel filter into the securing bracket and tighten retaining fastener
9. Ensure the gasoline fuel filter is mounted in the proper direction arrow should be in the direction of flow.
10. Reconnect the inlet and outlet fittings and tighten to specification.
11. Remove drain pan and discard any drained gasoline in a safe and proper manner
12. Start engine and check for leaks, repair if necessary.

FUEL PUMP MAINTENANCE AND INSPECTION

The fuel pump is specifically design to supply the correct fuel pressure to the injector pressure regulator. During normal engine operation excessive fuel from the fuel rails is bypassed back to the fuel tank. If the fuel pump fails to operate replace with the OEM replacement part only, substitute must supply to much fuel and cause excessive pressure in the fuel and damage to the fuel system.

When inspecting the fuel pump check the following;

- Check for leaks at the fuel pump.
- Check the inlet and outlet fittings for leaks.
- Check the electrical connection to ensure the connector is fully seated and locked.
- Check the fuel pump wire harness to ensure the harness is secure in its retaining device and that the wire harness is not chaffing or routed improperly.
- Check to make sure the fuel pump is securely mounted to the chassis.

FUEL PRESSURE REGULATOR MAINTENANCE AND INSPECTION

The gasoline fuel injection system utilizes a single stage pressure regulator to maintain a constant fuel supply to the fuel rails and injectors. The regulator is specifically designed and calibrated to meet the emission requirements of the certified engine. If the regulator fails to operate it should only be replaced with the OEM replacement part.

When inspecting the fuel pressure regulator check the following;

- Check for leaks at the inlet and outlet fitting of the regulator.
- Check for external leaks at the regulator
- Check to ensure the regulator is securely mounted
- Check the fuel inlet and outlet supply lines for cracks, chaffing or separations replace if any of these conditions exist

FUEL RAILS AND INJECTORS

The fuel delivery system of the gasoline injection system utilizes two fuel rails to supply fuel to the injectors. The gasoline fuel injectors supply the specific amount of fuel for the combustion cycle. The ECU sends a signal to the injector to open for the calibrated time for fuel delivery to the intake port. The injectors utilized for the emissions certified engines are specifically calibrated if an injector fails to operate it should only be replaced with the OEM replacement parts.

When inspecting the fuel rails and injector check the following:

- Check the fuel inlet line connections for leaks
- Check the fuel return line connections for leaks
- Check the fuel rail for leaks or external damage
- Check to ensure the fuel rail is securely mounted
- Check the fuel rail to injector connections for leaks
- Check the base of the injector for leaks
- Check the injector wire connections to ensure sure they are fully seated and locked
- Check the fuel pressure sender electrical connection to ensure they are fully seated and locked
- Check the fuel pressure sender connection at the fuel rail for leaks

FUEL ADDITIVES

The engine manufacturer does not recommend the use of Injector cleaners or fuel additives which clean fuel system parts. Use of such additives are unnecessary if the fuel system filter is change as required and clean refueling practices are practiced. Avoid storing fuel in containers which are not specifically designed to store gasoline. Avoid storing gasoline in dusty and dirty environments doing so will further prevent contamination of the fuel system.

PSI 1.6L Certified Small Off Road Engine Recommended Maintenance

Initial Start-Up Sequence Checks	Operation	Daily	Weekly	Every 50 hrs	Every 100 hrs	Every 200 hrs	Every 400 hrs	Every 800 hrs	As Req.
1	Check Engine Oil Level	x							
2	Check Coolant Level	x							
3	Check for Fluid Leaks	x							
	Change Engine Oil & Filter (1)					x			
4	Battery, Check Charge & Fluid Level		x						
	Inspect & Clean Radiator Exterior		x						
	Clean Battery Cables								x
5	Check Belts and Belt Tension				x				
	Inspect and Clean Air Cleaner Element		x						
	Replace Primary Air Cleaner Element (1)						x		
	Replace Safety Air Cleaner Element								x
	Check Coolant Protection & Tighten Hose Clamps						x		
	Replace Engine Coolant (3)							x	
	Replace Gasoline Fuel Filter (4)						x		
	Replace PCV Valve (If Equipped)							x	
	Check PCV Hoses, Tubes, and Fittings							x	
	Replace Spark Plugs (3)							x	
	Distributor Cap & Rotor (5)							x	
	Secondary Ignition Wires								x
6	Check All Engine Bolts & Nuts for Tightness								x

- (1) More frequent intervals may be required in dusty or dirty operating conditions.
- (2) Mechanical governor (belt driven).
- (3) To be performed at specified interval or annually, whichever occurs first.
- (4) More frequent intervals may be required with dirt in the fuel system.
- (5) Does not apply to engines with DIS ignition

SECTION 1A1

LPG VAPOR FUEL SYSTEM OPERATION

Description of Operation of System Components1A1-2-1A1-4

DESCRIPTION AND OPERATION OF THE FUEL SYSTEMS

PROPANE FUEL SYSTEM

The primary components of the propane fuel system are the fuel storage tank, low pressure regulator (LPR), fuel mixer, electronic throttle control device (ETC), 3-way pressure trim solenoid, engine control module (ECM).

LPG FUEL TANK

This system is a vapor withdrawal system. Fuel is supplied from the tank's Vapor Withdrawal Tube to a customer installed step down regulator. Vapor fuel is supplied to the engine's LPR at 10-12 in. H₂O at all load conditions.

1. Liquid Outage valve w/quick disconnect coupling	11. Vapor Withdrawal Tube (when applicable)
2. Filler Valve	12. 80% Limitor Tube
3. Pressure Relief Valve	13. Fuel Level Float
4. Liquid Outage Fill Check Valve	14. Liquid Withdrawal Tube
5. Fuel Gauge	

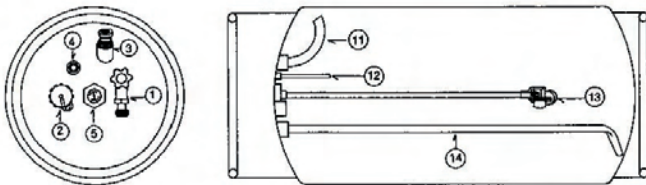

Figure 2 Typical Propane Cylinder

CAUTION

The bulkhead assembly should never be removed and a service line run throught the sheet metal.

LOW PRESSURE REGUALTOR (LPR)

CAUTION

The LPR is an emission control device. Components inside the regulator are specifically calibrated to meet the engine emissions requirements and should never be disassembled or rebuilt. If the LPR fails to operate, replace with an OEM replacement part.

The LPR on this engine is a single stage flow through design. Fuel pressure is regulated to -2.5 to -3 in. of H₂O at no load and no less than -10 in. of H₂O at full load.

The LPR on this emission certified engine is equipped with a 3-way pressure trim solenoid (Figure 3). This solenoid interacts with the fuel systems balance line. The balance line helps to bias the fuel pressure to account for restrictions in the engine's air intake/filtration system. The 3-way solenoid is designed to "pull" the system lean when commanded. The engine's fuel system is calibrated to be biased slightly richer than stoich. The ECM sends a PWM signal to the 3-way pressure trim solenoid, based on inputs from various engine sensors, to switch the system lean.

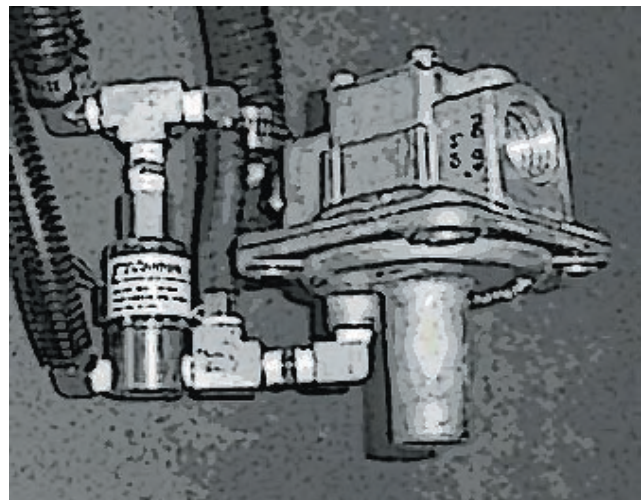

Figure 3 LPR with 3-Way Pressure Trim Solenoid

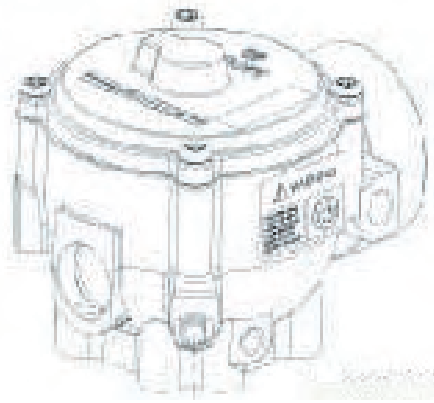

Figure 4 Air Fuel Mixer

AIR FUEL MIXER

The air valve mixer is an air-fuel metering device and is completely self-contained. The mixer is an air valve design, utilizing a relatively constant pressure drop to draw fuel into the mixer from cranking to full load. The mixer is mounted in the air stream ahead of the throttle control device.

When the engine begins to crank it draws in air with the air valve covering the inlet, negative pressure begins to build. This negative pressure signal is communicated to the top of the air valve chamber through 4 vacuum ports in the air valve assembly. A pressure/force imbalance begins to build across the air valve diaphragm between the air valve vacuum chamber and the atmospheric pressure below the diaphragm. The air valve vacuum spring is calibrated to generate from 101.6 mm (4.0 inches) of water column at start to as high as 355.60 mm (14.0 inches) of water column at full throttle. The vacuum being created is referred to as Air Valve Vacuum (AVV). As the air valve vacuum reaches 101.6mm (4.0 inches) of water column, the air valve begins to lift against the air valve spring. The amount of AVV generated is a direct result of the throttle position. At low engine speed the air valve vacuum is low and the air valve position is low thus creating a small venturi for the fuel to flow. As the engine speed increase the AVV increases and the air valve is lifted higher thus creating a much larger venturi.



CAUTION

The air/fuel mixer is an emission control device. Components inside the mixer are specifically calibrated to meet the engines emissions requirements and should never be disassembled or rebuilt. If the mixer fails to operate replace with an OEM replacement part.

The mixer has been preset at the factory and should not require any adjustment.

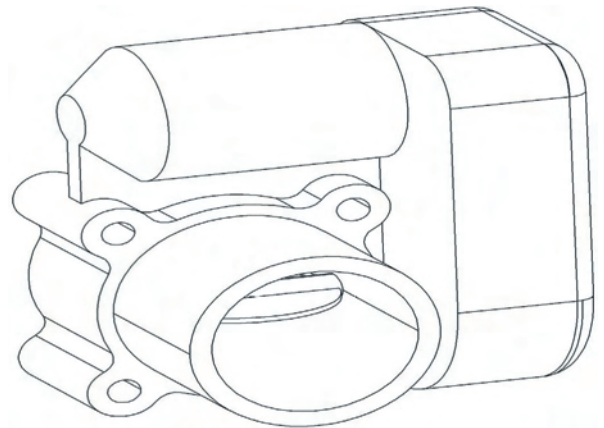

Figure 5 Electronic Throttle Control

THROTTLE CONTROL DEVICE

Drive By Wire

Engine speed control is maintained by Electronic Throttle Control device or ETC. The engine's run speed is maintained at a constant 100 rpm. The engine controller adjusts engine speed by sensing load changes and varying the position of the ETC. The amount of throttle opening is directly related to the amount of load on the engine. Defaults programmed into the ECM software and throttle position sensors allow the ECM to maintain safe operating control over the engine.

The electronic throttle control device also incorporates two internal Throttle Position Sensors (TPS) which provide input signals to the ECM as to the location of the throttle shaft and blade. The TPS information is used by the ECM to correct for speed and load control as well as emission control.



Figure 6 Engine Control Module

ENGINE CONTROL MODULE

To obtain accurate control of the air fuel ratio the emission certified engine is equipped with an onboard computer or Engine Control Module (ECM). The ECM is a 32 bit controller which receives input data from sensors fitted to the engine and fuel system and then outputs various signals to control engine operation.

One specific function of the controller is to maintain “closed loop fuel control”. Closed loop fuel control is accomplished when the exhaust gas oxygen sensor (HEGO) mounted in the exhaust system sends a voltage signal to the controller. The controller then calculates any correction that may need to be made to the air fuel ratio.

The controller also performs diagnostic functions on the fuel system and notifies the operator of malfunctions by turning on a Malfunction Indicator Light (MIL) mounted in the dash. Malfunctions in the system are identified by a Diagnostic Code number. In addition to notifying the operator of the malfunction in the system the controller also stores the information about the malfunction in its memory. A technician can then utilize a computerized diagnostic tool to retrieve the stored diagnostic code and by using the diagnostic charts in this manual determine the cause of the malfunction. In the event a technician does not have the computerized diagnostic tool the MIL light can be used to identify the diagnostic code. By following specific steps the technician can activate the “blink” feature and count the number of blinks to determine the diagnostic code number to locate the fault in the system.

HEATED EXHAUST GAS OXYGEN SENSOR



CAUTION

The Heated Exhaust Gas Oxygen Sensor (HEGO) is an emissions control component. If the HEGO fails to operate, replace only with an OEM replacement part. The HEGO sensor is sensitive to silicone and silicone based products and can become contaminated. Avoid using silicone sealers or hoses treated with silicone lubricant in the air stream or fuel supply lines.

The Heated Exhaust Gas Oxygen Sensor (HEGO) is mounted in the exhaust system downstream of the engine. The HEGO is used to measure the amount of oxygen present in the exhaust stream and communicate that to the ECM via an electrical signal. The amount of oxygen present in the exhaust stream indicates whether the fuel air ratio is too rich or too lean. If the HEGO sensor signal indicates that the exhaust stream is too rich the ECM will decrease or lean the fuel mixture during engine operation, if the mixture is too lean the ECM will richen the mixture. The ECM continuously monitors the HEGO sensor output if a rich or lean condition is present for an extended period of time and the ECM cannot correct the condition the ECM will set a diagnostic code and turn on the MIL light in the dash.



Figure 10 Heated Exhaust Gas Oxygen Sensor (HEGO)

SECTION 1A2

GASOLINE FUEL SYSTEM OPERATION

Description of Operation of System Components ...1A2-2-1A2-5

THROTTLE CONTROL DEVICE

Drive By Wire

Engine speed control is maintained by Electronic Throttle Control device or ETC. The engine's run speed is maintained at a constant 100 rpm. The engine controller adjusts engine speed by sensing load changes and varying the position of the ETC. The amount of throttle opening is directly related to the amount of load on the engine. Defaults programmed into the ECM software and throttle position sensors allow the ECM to maintain safe operating control over the engine.

The electronic throttle control device also incorporates two internal Throttle Position Sensors (TPS) which provide input signals to the ECM as to the location of the throttle shaft and blade. The TPS information is used by the ECM to correct for speed and load control as well as emission control.

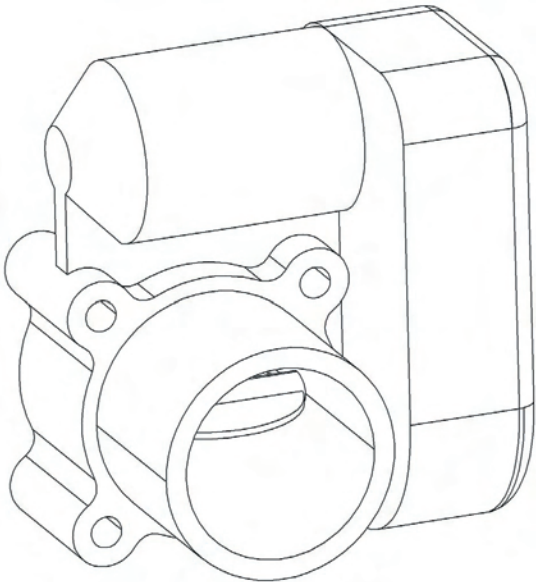

Figure 3 Throttle control device "Drive by Wire throttle body assembly"

ENGINE CONTROL UNIT

To obtain maximum effect from the catalyst and accurate control of the air fuel ratio the emission certified engine is equipped with an onboard computer or Engine Control Unit (ECM). The ECM is a 32 bit controller which receives input data from sensors fitted to the engine and fuel system and then outputs various signals to control engine operation.

One specific function of the controller is to maintain "closed loop fuel control". Closed loop fuel control is accomplished when the exhaust gas oxygen sensor (EGO) mounted in the exhaust system sends a voltage signal to the controller. The controller then calculates any correc-

tion that may need to be made to the air fuel ratio.

The controller also performs diagnostic functions on the fuel system and notifies the operator of malfunctions by turning on a Malfunction Indicator Light (MIL) mounted in the dash. Malfunctions in the system are identified by a Diagnostic Code number. In addition to notifying the operator of the malfunction in the system the controller also stores the information about the malfunction in its memory. A technician can then utilize a computerized diagnostic tool to retrieve the stored diagnostic code and by using the diagnostic charts in this manual determine the cause of the malfunction. In the event a technician does not have the computerized diagnostic tool the MIL light can be used to identify the diagnostic code. By following specific steps the technician can activate the "blink" feature and count the number of blinks to determine the diagnostic code number to locate the fault in the system.

Figure 5 Gasoline Engine Control Module (ECM)

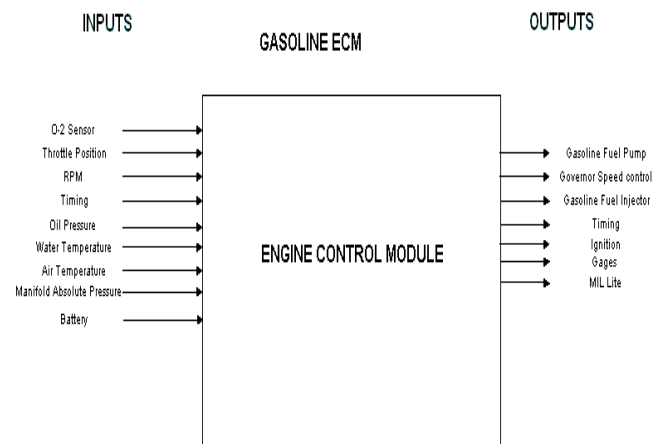

HEATED EXHAUST GAS OXYGEN SENSOR



CAUTION

The Heated Exhaust Gas Oxygen Sensor (HEGO) is an emissions control component. If the HEGO fails to operate, replace only with an OEM replacement part. The HEGO sensor is sensitive to silicone and silicone based products and can become contaminated. Avoid using silicone sealers or hoses treated with silicone lubricant in the air stream or fuel supply lines.

The Heated Exhaust Gas Oxygen Sensor (HEGO) is mounted in the exhaust system downstream of the engine. The HEGO is used to measure the amount of oxygen present in the exhaust stream and communicate that to the ECM via an electrical signal. The amount of oxygen present in the exhaust stream indicates whether the fuel air ratio is too rich or too lean. If the HEGO sensor signal indicates that the exhaust stream is too rich the ECM will decrease or lean the fuel mixture by reducing the signals to the injectors during engine operation, if the mixture is too lean the ECM will enrich the mixture or increase the pulse to the injectors. The ECM continuously monitors the HEGO sensor output if a rich or lean condition is present for an extended period of time and the ECM cannot correct the condition the ECM will set a diagnostic code and turn on the MIL light in the dash.



Figure 6 Exhaust Gas Oxygen Sensor (EGO)

GASOLINE MULTI POINT FUEL INJECTION SYSTEM (MPFI)

The primary components of the Gasoline Multi Point Fuel Injection (MPFI) fuel system are the gasoline fuel tank, electric fuel pump, fuel filter, fuel rails, fuel pressure regulator, fuel injector, O2 sensor and the engine control module.

GASOLINE FUEL STORAGE TANK

The gasoline fuel storage tank location may vary on equipment applications. The fuel tank may be integrated into the chassis frame or may be a stand alone vessel mounted on the equipment. For precise location for the equipment application refer to the OEMs vehicle manual.

GASOLINE FUEL PUMP



CAUTION

If the fuel pump fails to operate, replace only with an OEM replacement part. The fuel pump is calibrated to supply the correct amount of fuel to the injectors. Replacing the pump with anything other than the OEM replacement could cause damage to the fuel system and or damage to the fuel tank.

The Gasoline is stored as a liquid in the fuel tank and is drawn into the fuel system by a 12 volt electric fuel pump. Depending on the application the fuel pump may be mounted near the fuel tank or as a stand alone component. In either case the fuel pump will receive a signal from the ECM at Key On to prime the fuel system for approximately 2 seconds prior to start. Priming of the fuel system provides for a quicker start, when the engine begins to crank.

FUEL FILTER

After the fuel is drawn into the fuel pump the fuel then flows through the gasoline fuel filter. The fuel filter will trap small particles as the fuel passes through the filter to remove debris and prevent injectors from becoming damaged. Maintenance of the fuel filter is required as indicated in the *Recommended Maintenance Schedule*. A more frequent replacement of the filter may be required if the equipment operates in a dusty or dirty environment.

FUEL RAIL AND PRESSURE REGULATOR

The fuel flows from the fuel filter to the fuel rails where the fuel is regulated. During engine operation the regulator maintains the proper amount of fuel pressure to the top of the injector. During lower RPM operation excess fuel at the top of the injector is bypassed and returned to the fuel tank for recirculation.

The Fuel pressure regulator has no adjustments and is integrated into the fuel rail assembly. The fuel rail also contains a Schrader valve which is utilized to test the regulated pressure of the fuel system.

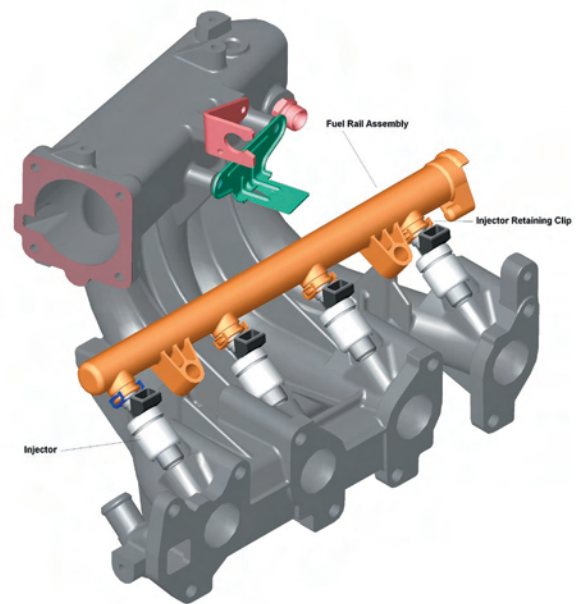

Figure 2 Gasoline Fuel Rail Assembly with injectors

FUEL INJECTOR

The fuel supply is maintained on the top of the injector by the fuel pressure regulator. The injector receives a “pulse” signal through the wire harness which causes the injector to open. During regular operating conditions the ECM controls the duration, or on-time, of the injector. During lower RPM operation the injector signals or “pulses” are less frequent than when the engine is operating at higher RPMs. This certified engine has been calibrated to deliver the precise amount of fuel for optimum performance and emission control.

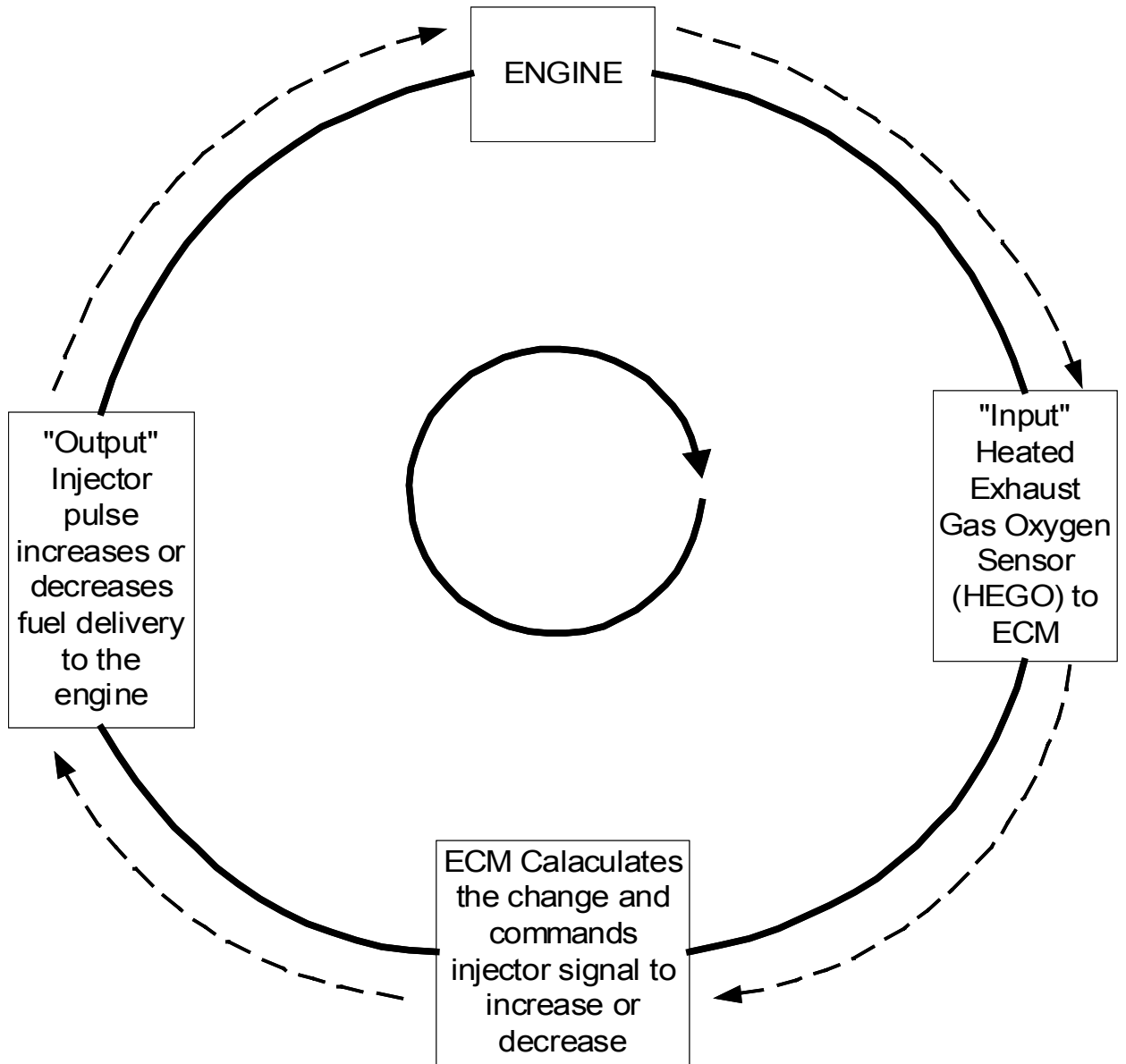

Figure 7 Gasoline Closed Loop Control Schematic

SECTION 1B1

LPG SYSTEM DIAGNOSIS

LPG System Description and Diagnostic Aids	1B1-2
LPG Fuel System Diagnosis	1B1-3-1B1-4
Fuel Control Diagnosis	1B1-5-1B1-6

LPG FUEL SYSTEM DIAGNOSIS

DIAGNOSTIC AIDS

This procedure is intended to diagnose a piece of equipment operating on LPG. If the equipment will not continue to run on LPG, refer to *Hard Start* for preliminary checks. Before proceeding with this procedure, verify that the equipment has a sufficient quantity of fuel and that fuel is being delivered to the LPR. Also, ensure that the manual shut off valve on the LPG tank is fully opened and that the excess flow valve has not been activated.

Tools Required:

- DVOM (GM J 39200, Fluke 88 or equivalent).
- PSI Display - Laptop Based Engine Diagnostic Scan Tool
- Water Column Gauge / Manometer (0-20 +/-).

LPG Fuel System Diagnosis

Step	Action	Value(s)	Yes	No
1	Were you referred to this procedure by a DTC diagnostic chart?	---	Go to <i>Step 3</i>	Go to <i>Step 2</i>
2	Perform the On Board Diagnostic (OBD) System Check. Are any DTCs present in the ECM?	---	Go to the applicable DTC Table	Go to <i>Step 3</i>
3	Verify that the LPG fuel tank has a minimum of 1/4 tank of fuel, that the manual valve is open and the tank quick connect is fully engaged Does the tank have fuel?	---	Go to <i>Step 4</i>	---
4	1. Connect a water column gauge or a manometer to check supply pressure to the engine LPR. 2. Start the engine and allow it to reach operating temperature. Does the engine start and run?	---	Go to <i>Step 5</i>	Go to <i>Step 8</i>
5	With the engine idling, observe the pressure reading for the LPR supply pressure. Is the pressure within the specified range?	10" to 12" w.c.	Go to <i>Step 6</i>	Repair supply pressure to engine LPR.
6	1. Connect a water column gauge or manometer to the outlet test port on the engine LPR. 2. With the engine running with no load observe the pressure reading. Note: Air filtration system must be connected. Is the fuel pressure WITHIN the specified range?	-2.5" to -3.0" w.c.	Go to <i>Fuel Control System Diagnosis</i>	Go to <i>Step 7</i>
7	1. Inspect the air intake stream between the mixer assembly and the throttle body for leaks. 2. Inspect the air filter. If it is dirty, replace it and recheck. 3. Inspect the hoses to the 3-way pressure trim solenoid. Was a problem found and corrected?	---	System OK	Go to <i>Step 11</i>

8	<p>1. Remove Air induction hose to the mixer 2. Observe the air valve for movement while the engine is cranking. Note: Movement of the air valve will be minimal at cranking speeds.</p> <p>Does the air valve move when the engine is cranked?</p>	---	Go to <i>Step 10</i>	Go to <i>Step 9</i>
9	<p>1. Inspect the air intake stream to the mixer assembly and the throttle body for vacuum leaks. 2. Inspect the vacuum hoses from the mixer to the 3-way pressure trim solenoid for proper connection and condition.</p> <p>Was a problem found and repaired?</p>	---	Go to <i>Step 14</i>	Go to <i>Step 13</i>
10	<p>Inspect the fuel hose connection between the LPR and the mixer assembly for damage or leakage.</p> <p>Was a problem found and repaired?</p>	---	Go to <i>Step 14</i>	Check and ep-air fuel supply to the engine LPR
11	<p>Remove the seal cap on the regulator and adjust the outlet pressure to specified value. the low pressure regulator (LPR). Refer to <i>Low Pressure Regulator Replacement</i>.</p> <p>Is the action complete?</p>	-2.5" to -3.0" w.c.	Go to <i>Step 14</i>	Go to <i>Step 12</i>
12	<p>Replace the <i>LPR</i>.</p> <p>Is the action complete?</p>	---	Go to <i>Step 14</i>	---
13	<p>Replace the mixer assembly.</p> <p>Is the action complete?</p>	---	Go to <i>Step 14</i>	---
14	<p>1. Disconnect all test equipment 2. Install the primary and secondary test port plugs. 3. Start the engine. 4. Using SNOOP® or equivalent, leak check the test port plugs.</p> <p>Is the action complete?</p>	---	System OK	---

FUEL CONTROL DIAGNOSIS

STEP	ACTION	VALUE(S)	YES		NO	
1	Were you referred to this procedure by another diagnostic chart?					
			Go to Step	3	Go to Step	2
2	Perform the On-Board Diagnostic (OBD) System check		Go to Applicable DTC Table			
	Are any DTC's present in the ECM				Go to Step	3
3	Has the Fuel Ssystem diagnosis been performed?		Go to Step	4	Go to Fuel system Diagnosis	
4	1. Connect the Diagnostic Scan tool. 2. Start the engine and allow it to reach operating temperature 3. With the engine running at no load, observe the Primary Trim Valve duty cycle reading on the scan tool OR Back probe the trim valve connector. Connect a duty cycle monitoring tool at the trim valve connector.	60% - 80%				
	Is the duty cycle within the specified range?		Go to Step	13	Go to Step	5
5	1. Connect the negative lead of the DVOM to a know good engine ground 2. Using the positive lead of the DVOM Back-probe Pin B at the trim valve connector	12.6 V to 15.1 V				
	Was the voltage within the specified range?		Go to Step	7	Go to Step	6
6	1. Turn the engine OFF 2. Disconnect the ECU connector C001 3. Disconnect the fuel system interface electrical connector 4. Check the trim valve power circuit terminal F for continuity to the ECU connector pin number 21.					
	Was a problem found?		Go to Step	10	Go to Step	9
7	Using the DVOM measure the resistance at the trim valve terminals.					
	Was the resistance measured within specification?	15-35 Ω	Go to Step	8	Go to Step	12

8	<ol style="list-style-type: none"> 1. Turn the engine OFF 2. Disconnect the ECU connector C001 3. Disconnect the fuel system interface electrical connector 4. Check the ground circuit terminal E for continuity to the ECU connector pin 15 					
	Was a problem found?		Go to Step	10	Go to Step	11
9	Replace the Engine Control Unit (ECU). <i>Refer to Engine Control Unit (ECU) replacement</i>					
	Is this action complete?		Go to Step	14	Re-trace steps	
10	Repair the open or damaged circuit?					
	Is this action complete?		Go to Step	14	Go to Step	
11	Check the vacuum hose to the trim valve for kinks, obstruction or leakage					
	Was a problem found?		Go to Step	14	Go to Step	9
12	Replace the pressure trim valve.					
13	The fuel control system is operating normally. Refer to Symptoms Diagnosis <ol style="list-style-type: none"> 1. Disconnect all test equipment 2. If you were sent to this routine by another diagnostic chart, retune to the previous diagnostic procedure, 					
	Is this action complete					
14	<ol style="list-style-type: none"> 1. Disconnect all test equipment 2. Start the engine 3. Using a liquid leak detection solution leak check any fuel system repairs made. 					
	Is this action complete					

SECTION 1B2

GASOLINE SYSTEM DIAGNOSIS

Gasoline System Description B2-2 - 1B2-3
Gasoline Fuel System Diagnosis1B2-4-1B2-6

GASOLINE FUEL SYSTEM DIAGNOSIS

FUEL SYSTEM DESCRIPTION

The Engine Control Module (ECM) receives information from various engine sensors in order to control the operation of the fuel injectors. The electric fuel pump, prevents fuel flow unless the engine is cranking or running. During key on, electric fuel pump receives a two (2) second prime pulse from the ECM which allows Gasoline to flow from the tank through fuel filter and fuel lines to the fuel rails where the pressure is regulated. With Ignition "ON" and fuel pump running pressure should be 284-325 kPa (41-47 psi).

When the engine is idling, manifold pressure is low (high vacuum) and is applied to the pressure regulator diaphragm. Vacuum will offset the spring pressure and result in very low fuel pressure. Fuel pressures at idle will vary somewhat depending on barometric pressure but, should be less than pump pressure.

Unused fuel is returned to the fuel tank by a separate return fuel line

The fuel pump pressure test port is located on the fuel rail

DIAGNOSTIC AIDS

This procedure is intended to diagnose a vehicle operating on Gasoline. If the vehicle will not continue to run on Gasoline, refer to *Hard Start* for preliminary checks. Before proceeding with this procedure, verify that the vehicle has a sufficient quantity of fuel.

Tools Required:

- J 34730-1 or equivalent
- J 37287 or equivalent

Diagnostic Scan Tool

- PSI Display - Laptop Based Engine Diagnostic Scan Tool

Test Description

The numbers below refer to step numbers on the diagnostic table.

4. Connect fuel pressure gage as shown in illustration. Wrap a shop towel around the fuel connection to absorb any small amount of fuel leakage that may occur when installing the gage. With ignition "ON" and the fuel pump running pressure should be 284-325 kPa (41-47 psi). This pressure is controlled by spring pressure within the regulator assembly.
6. When the engine is idling, manifold pressure is low (High Vacuum) and is applied to the pressure regulator diaphragm. Vacuum will offset spring pressure and result in a lower pressure. Fuel pressure at idle will vary somewhat depending on barometric pressure but, should be less than the pressure noted in step 4.
11. Fuel pressure that drops off during acceleration or cruise may cause a lean condition and result in a loss of power, surging or misfire. This condition can be diagnosed using the Diagnostic Tool. If the fuel in the system is very lean the Heated Exhaust Gas Oxygen (HEGO) will stop toggling and output voltage will drop below 300 mV. Also injector pulse will increase.
14. Fuel pressure below 284 kPa (41 psi) may cause lean condition and may set a DTC. Driveability conditions can include hard starting cold, hesitation, and lack of power or misfire.
15. Restricting the fuel return pipe cause the fuel pressure to build above the regulated pressure. With battery voltage applied to the pump, pressure should rise above 325 kPa (47 psi) as the valve in the return pipe is partially closed.

17. Fuel pressure above 325 kPa (47 psi) may cause a rich condition and set a DTC. Driveability may include hard starting, followed by black smoke and a strong sulphur smell in the exhaust.

18. This test is to determine if the high fuel pressure is due to a restricted fuel return pipe or a faulty fuel pressure regulator.

21. The pressure regulator may be fitted with a screen which is designed to trap contaminants introduced during engine assembly. If dirty it can be removed with a small pick and discarded without potential harm to the regulator.

23. A system that does not hold pressure is caused by one of the following.

- o Leaking fuel pump check ball
- o Leaking fuel feed hose
- o Leaking valve/seat within the pressure regulator
- o Leaking injector

26. A leaking injector can best be determined by checking for a fouled or saturated spark plug(s). If a leaking injector can not be determined by a fouled or saturated plug the following procedure should be used.

- Remove the fuel rail but leave the lines connected
- Lift the fuel rail out just enough to leave injector nozzle's in the ports.



CAUTION

To reduce the risk of fire or personal injury that may result from fuel spray on the engine, make sure fuel rails is positioned over injector port and injector retaining clips are intact.

- Pressurize the fuel system and observe injector nozzles.

NOTICE: Do not allow the pressure to exceed 414 kPa (60 psi) as damage to the regulator may result.

Gasoline Fuel System Diagnosis

Step	Action	Value(s)	Yes	No
1	Were you referred to this procedure by a DTC diagnostic chart?	---	Go to Step 3	Go to Step 2
2	Perform the On Board Diagnostic (OBD) System Check. Are any DTCs present in the ECM?	---	Go to the applicable DTC Table	Go to Step 3
3	Verify that the Gasoline fuel tank has a minimum of 1/4 tank of fuel, Does the vehicle have fuel?	---	Go to Step 4	---
4	1. Connect a fuel pressure gage at the Schrader Valve located on the fuel rail 2. Ignition "ON" fuel pump will run. 3. Note the pressure 4. Turn ignition off pressure may vary slightly then hold steady Is pressure within specified values	285-325 kPa (41-47 psi)	Go to Step 5	Go to Step 10
5	Did the fuel pressure hold steady after the pump stopped?		Go to Step 6	Go to Step 22
6	1. Start engine allow it to warm to normal operating temperature at idle 2. Fuel pressure noted in step 4 should drop. Did pressure drop by the specified value?	21-69 kPa (3-10 psi)	Go to 27	Go to Step 7
7	1. Disconnect the vacuum hose from the pressure regulator 2. With the engine idling, apply 12-14 inches of vacuum to the pressure regulator, pressure should drop. Did the pressure drop by the specified value?	21-69 kPa (3-10 psi)	Go to Step 8	Go to Step 9
8	1. Locate and repair loss of vacuum to the pressure regulator. Is the action complete?	---	Go to Step 27	

9	Replace pressure regulator Is the action complete?	---	Go to <i>Step 27</i>	
10	Is pressure less then specified value?	285-325 kPa (41-47 psi)	Go to <i>Step 14</i>	Go to <i>Step 11</i>
11	1. With the fuel pressure gage installed 2. Start engine and accelerate with load Is pressure less then specified value?	285-325 kPa (41-47 psi)	Go to <i>Step 12</i>	Go to <i>Step 14</i>
12	1. Check for restricted fuel filter 2. Check for restricted fuel supply line from pump Was a problem found?		Go to <i>Step 27</i>	Go to <i>Step 13</i>
13	1. Replace fuel pump Is this action Complete?	---	Go to <i>Step 27</i>	
14	With the ignition "OFF" 1. Install a 10 amp fused jumper to the B+ 2. Slowly pinch the fuel return line 3. Pressure should rise NOTE: Do not exceed 414 kPa (60 psi) Did Pressure rise?	325 kPa (47 psi)	Go to <i>Step 9</i>	Go to <i>Step 15</i>
15	1. Check for restricted fuel pump strainer 2. Check for leaking fuel supply line from pump 3. Check to ensure fuel pump is correct Was a problem found?		Go to <i>Step 27</i>	Go to <i>Step 16</i>
16	1. Replace fuel pump Is this action Complete?	---	Go to <i>Step 27</i>	
17	Is pressure greater then specified value?	285-325 kPa (41-47 psi)	Go to <i>Step 15</i>	
18	1. Disconnect the fuel return hose at the fuel rail 2. Attach a length of hose to the return pipe at the rail 3. Place the other end of the hose in an approved Gasoline container 4. Turn ignition "OFF" for 10 seconds 5. Turn ignition "ON" Is pressure within specified value?	285-325 kPa (41-47 psi)	Go to <i>Step 19</i>	Go to <i>Step 20</i>

19	The fuel return hoses are plugged or restricted, locate and repair the problem. Is the action complete?	---	Go to <i>Step 27</i>	---
20	Check for restricted engine return pipe Was a problem found?	---	Go to <i>Step 27</i>	Go To <i>Step 21</i>
21	Remove pressure regulator and check for restriction Was a problem found?	---	Go to <i>Step 27</i>	Go to <i>Step 9</i>
22	Fuel Pressure is within spec but does not hold pressure	---	Go to <i>Step 23</i>	---
23	<ol style="list-style-type: none"> 1. Install J 37287 fuel line shut off adapter or suitable valve to close off fuel supply 2. Make sure valve is open 3. With the ignition "OFF" 4. Install a 10 amp fused jumper to the B+ 5. Pressure should rise 6. Disconnect the jumper and close valve Did pressure hold?	---	Go to <i>Step 24</i>	Go to <i>Step 25</i>
24	Check for leaking fuel pump supply line. Was there a problem found?	---	Go to <i>Step 27</i>	Go to <i>Step 13</i>
25	Open valve in fuel pressure pipe Reconnect test jumper and wait for pressure to build Disconnect jumper and close valve in fuel pressure pipe Does Pressure hold	---	Go to <i>Step 9</i>	Go to <i>Step 26</i>
26	1. Locate and correct leaking injectors Is the action complete?	---	Go to <i>Step 27</i>	---
27	<ol style="list-style-type: none"> 1. Disconnect all test equipment 2. Install the test port cap. 3. Start the engine. 4. Verify engine is in closed loop and no MIL is on. Is the action complete?	---	System OK	---

SECTION 1C2

ENGINE CONTROL SYSTEM ELECTRICAL

Wire Harness Service Repairs	1C2-2 - 1C2-3
Main Engine Harness Schematic.	1C2-4 - 1C2-5
Dedicated LPG Jumper Harness	1C2-6 - 1C2-7
Dedicated Gasoline Jumper Harness	1C2-8 - 1C2-9
Harness Connector End Views	1C2-10 - 1C2-32

WIRE HARNESS SERVICE REPAIR

The ECM/PCM harness electrically connects the ECM/PCM to the various solenoids, electrically and sensors in vehicle engine and passenger compartment.

Wire harnesses should be replaced with proper part number harnesses. When signal wires are spliced, into a harness, use wire with high temperature insulation only. With the low current and voltage levels found in the system, it is important that the best possible bond at all wire splices be made by soldering the splices, as shown in Figure 3-20.

Molded on connectors require complete replacement of the connector. This means splicing a new connector assembly into the harness.

Refer to Figure 1 for wiring diagrams.

CONNECTORS AND TERMINALS

Use care when probing a connector or replacing terminals in them. It is possible to short between opposite terminals. If this happens to the wrong terminal pair, it is possible to damage certain components. Always use jumper wires between connectors, for circuit checking. NEVER probe through

the Weather-Pack seals. Use tachometer adapter J 35812, or equivalent, which provides an easy hook up of the tach. lead. The connector test adapter kit J 35616, or equivalent, contains an assortment of flexible connectors, used to probe terminals during diagnosis. Fuse remover and test tool BT 8616, or equivalent, is used for removing a fuse and to adapt fuse holder, with a meter, for diagnosis.

When diagnosing, open circuits are often difficult to locate by sight, because oxidation, or terminal misalignment are hidden by the connectors. Merely wiggling a connector on a sensor, or in the wiring harness, may correct the open circuit condition. This should always be considered, when an open circuit, or failed sensor is indicated. Intermittent problems may, also, be caused by oxidized or loose connections.

Before making a connector repair, be certain of the type of connector. Weather-Pack and Compact Three connectors look similar, but are serviced differently.

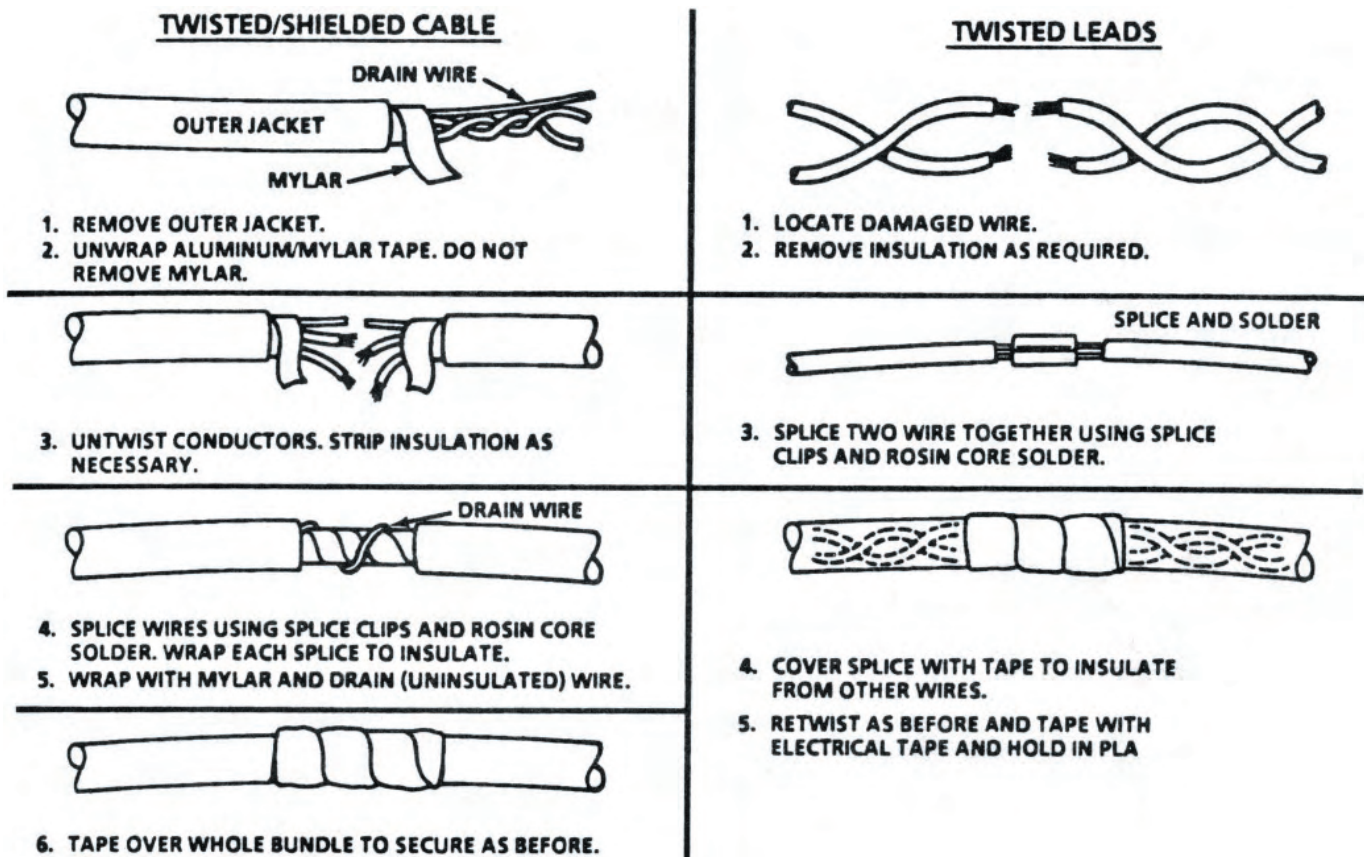
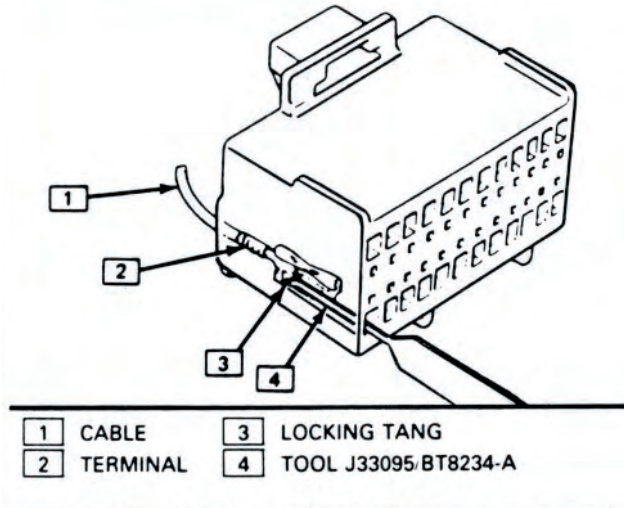

FIGURE 1 WIRE HARNESS REPAIR

Micro-Pack

Refer to Figure 2 and repair procedure for replacement of a :Micro-Pack terminal.

FIGURE 2 MICRO-PACK CONNECTOR



Metri-Pack

Some connectors use terminals called Metri-Pack Series 150. (Figure 3). These may be used at the coolant sensor, as well as TBI units.

They are also called "Pull-To-Seat" terminals, because, to install a terminal on a wire, the wire is first inserted through the seal (5) and connector (4). The terminal is then crimped on the wire and the terminal pulled back into the connector to seat it in place.

To remove a terminal:

1. Slide the seal back on the wire.
2. Insert tool (3) BT-8518, or J 35689, or equivalent, as shown in insert "A" and "B," to release the terminal locking tab (2).
3. Push the wire and terminal out through the connector.

If reusing the terminal, reshape the locking tang (2).

Weather-Pack

A Weather-Pack connector can be identified by a rubber seal, at the rear of the connector. This connector, which is used in the engine compartment, protects against moisture and dirt, which could create oxidation and deposits on the terminals. This protection is important, because of the very low voltage and current levels found in the electronic system.

Repair of a Weather-Pack terminal is shown in Figure 3-23. Use tool J M28742, or BT8234-A to remove the pin and sleeve

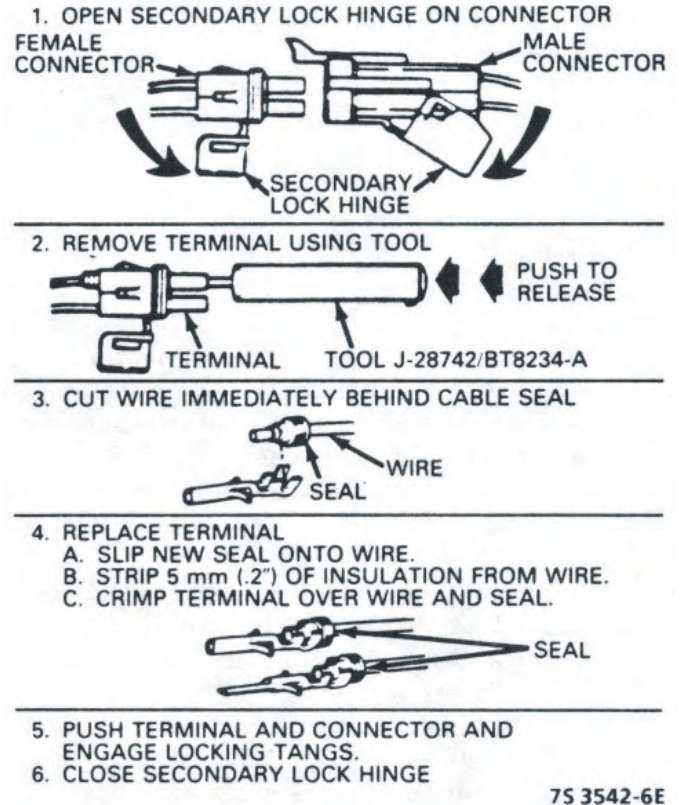
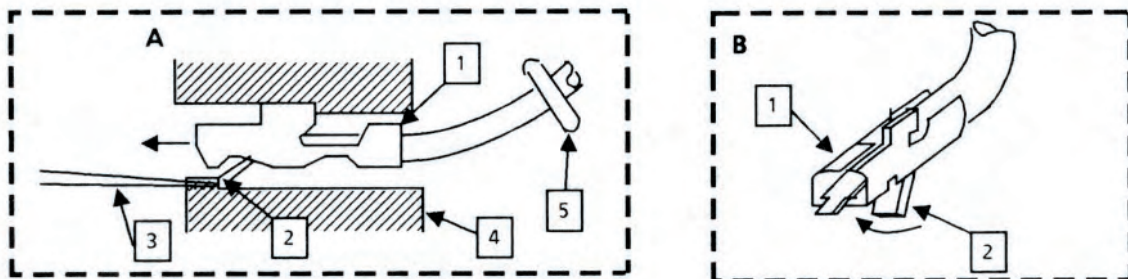
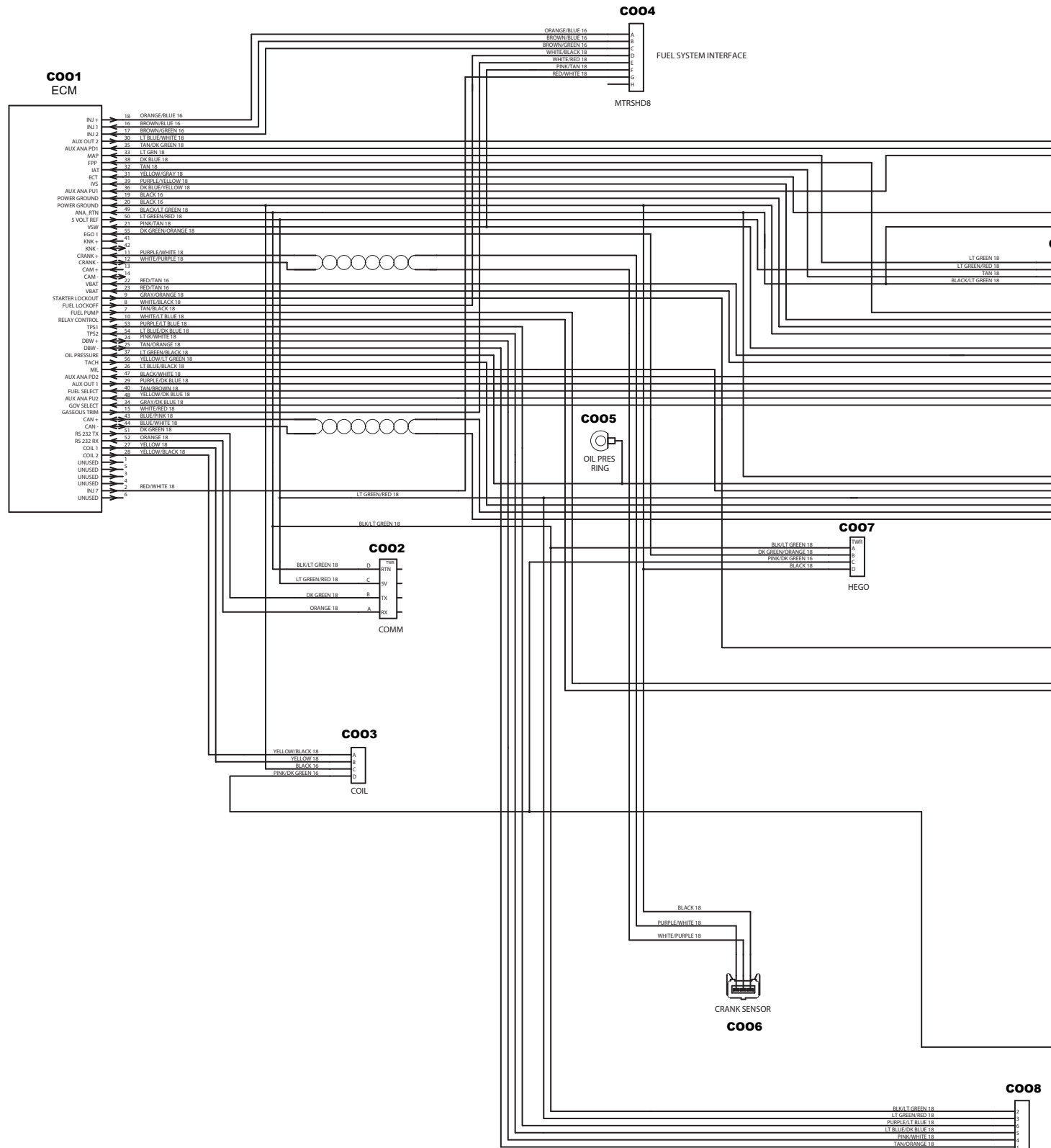

FIGURE 3 WEATHER PACK TERMINAL REPAIR



- | | |
|--|---------------------------|
| 1. METRI-PACK SERIES 150 FEMALE TERMINAL | 3. TOOL J35689 OR BT-8446 |
| 2. LOCKING TANG | 4. CONNECTOR BODY |
| | 5. SEAL |

FIGURE 2 METR-PACK SERIES 150 TERMINAL REMOVAL



HARNESS

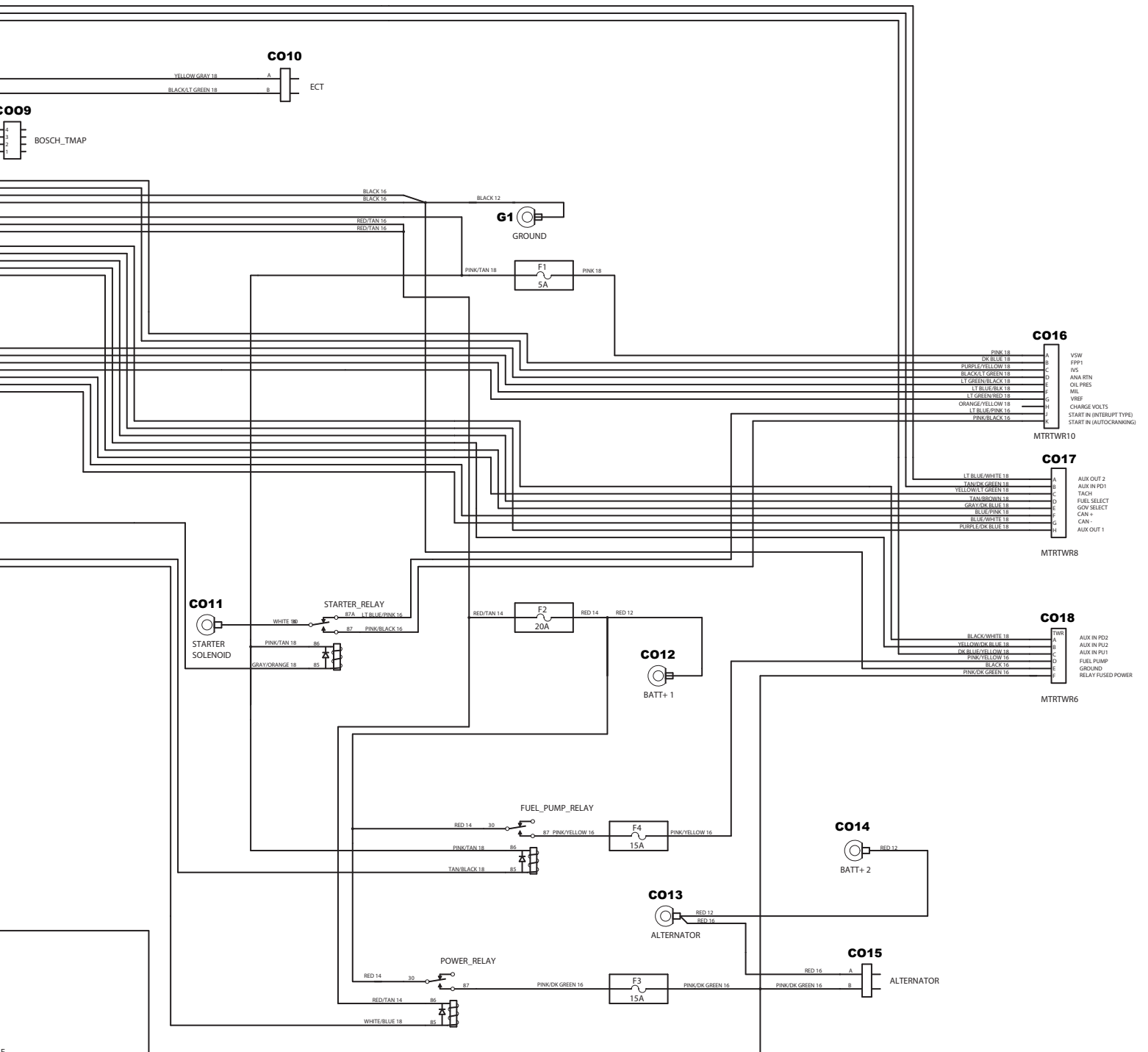

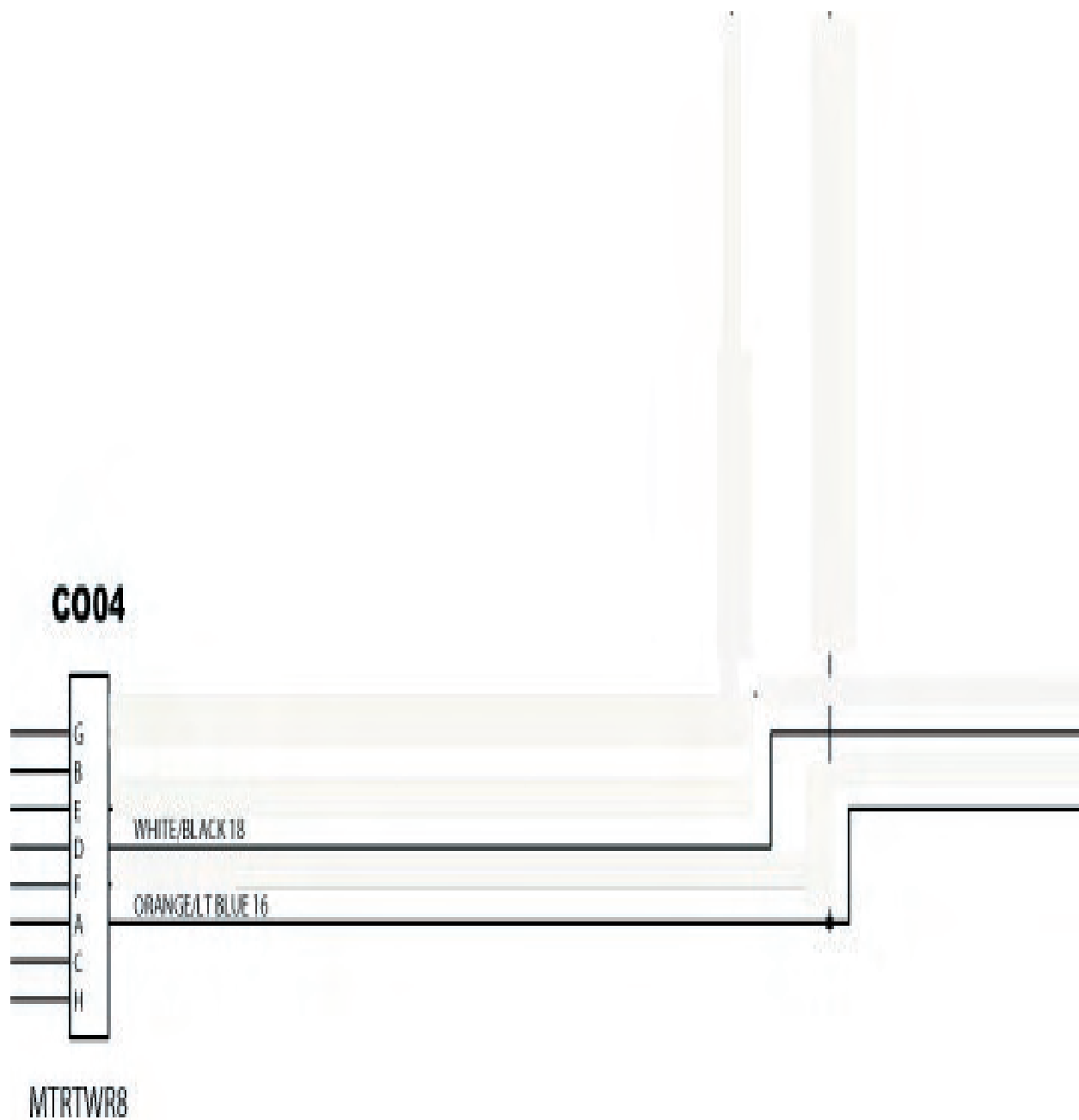

MP HARNESS

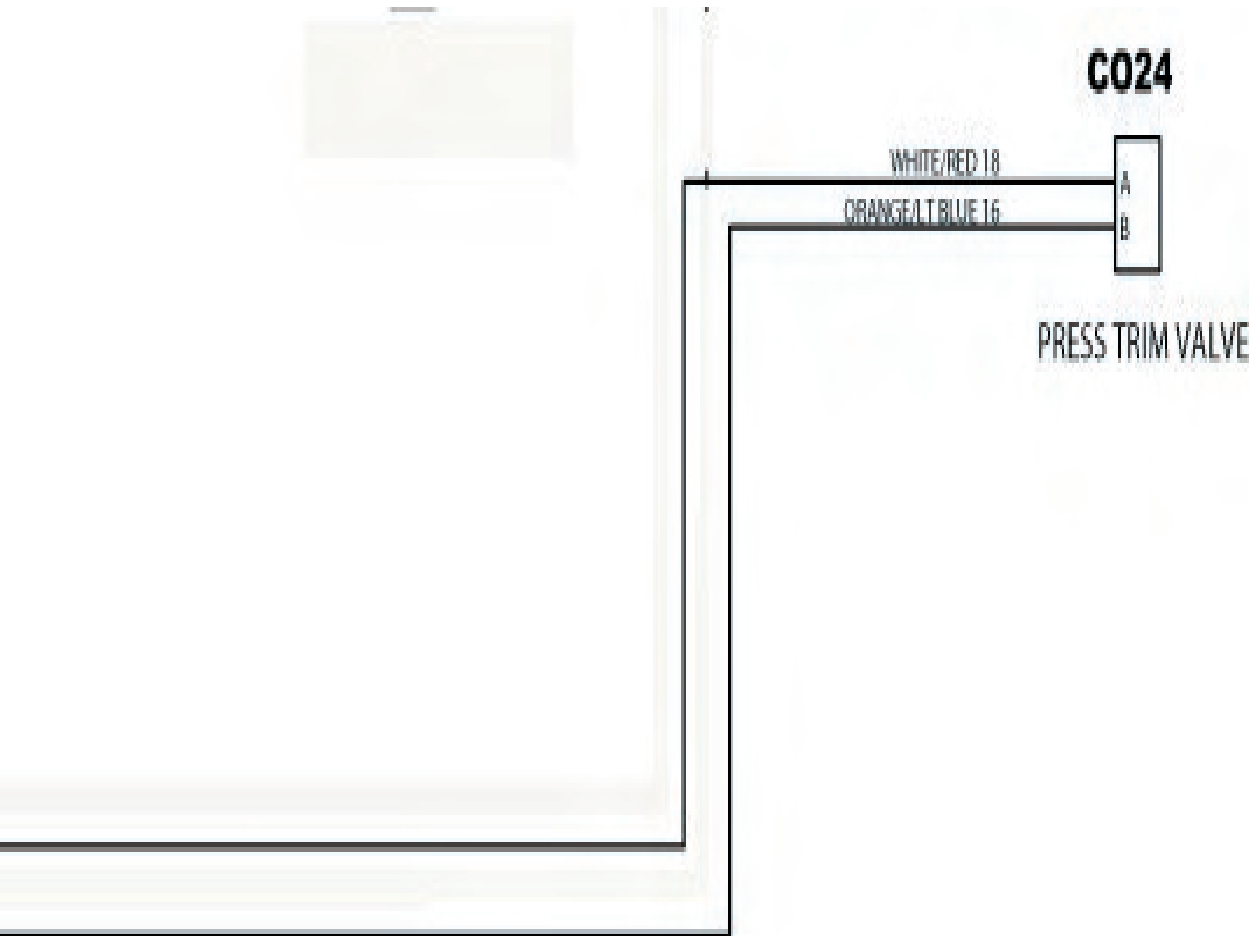

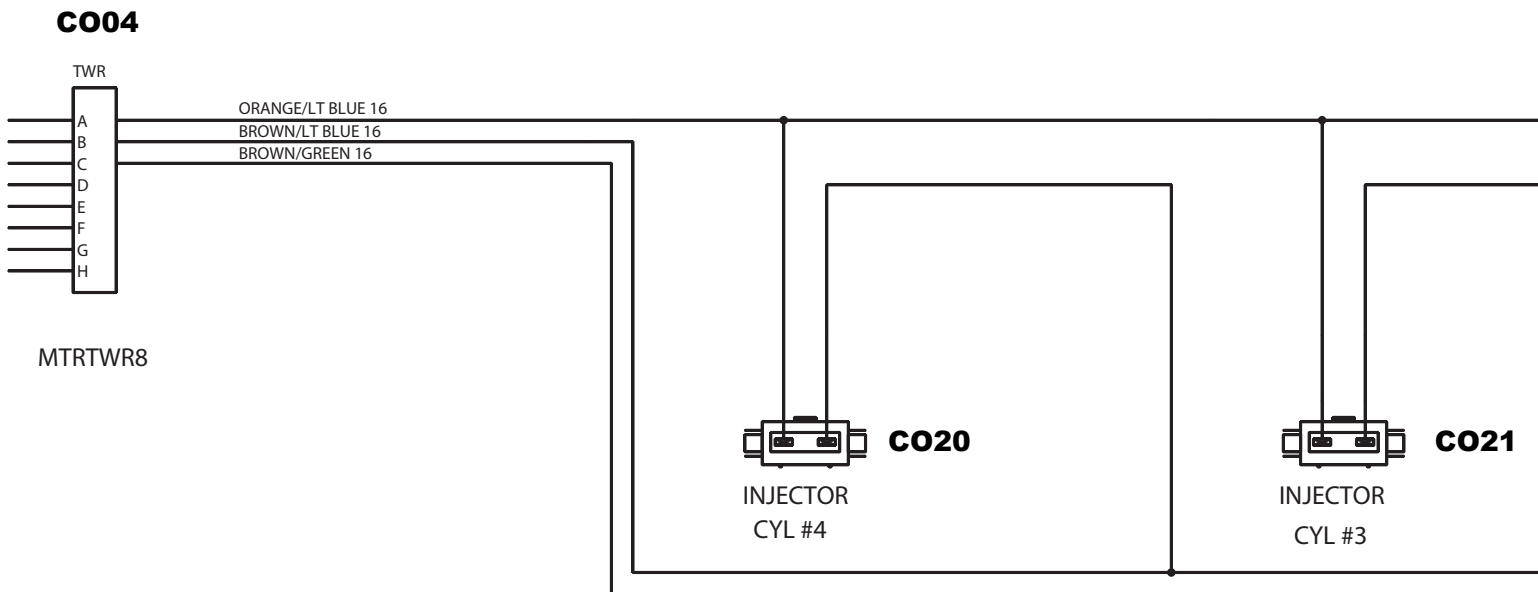

LINE JUMP NESS

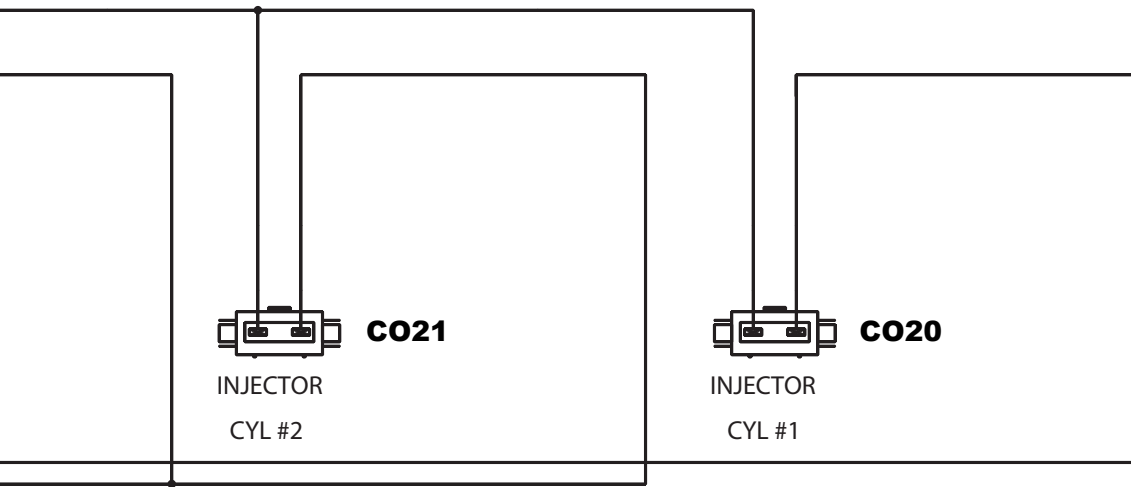

ECM CONNECTOR C001

ECM

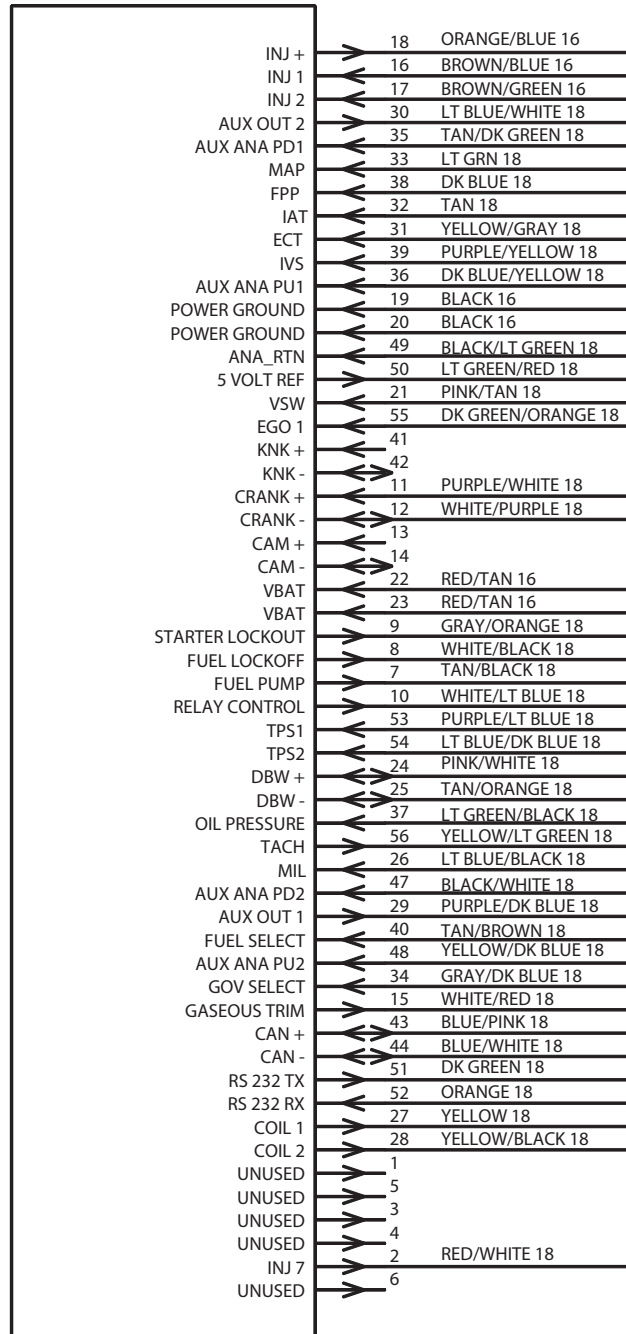

COMMUNICATION PORT C002

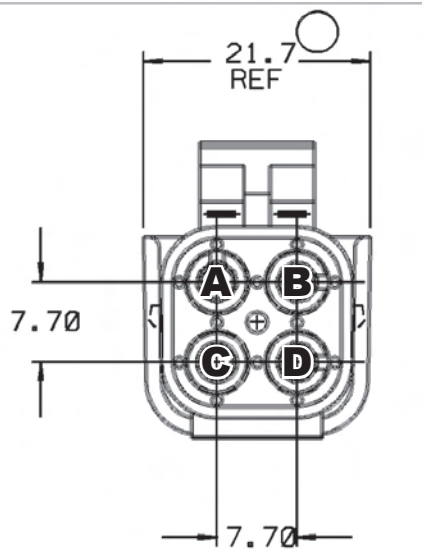

Pin	Wire Color	Function
A	Orange	RS232 RX
B	Dark Green	RS232 TX
C	Lt Green/Red	5 Volt Ref
D	Black/Lt Green	Ana Rtn

COIL CONNECTOR C003

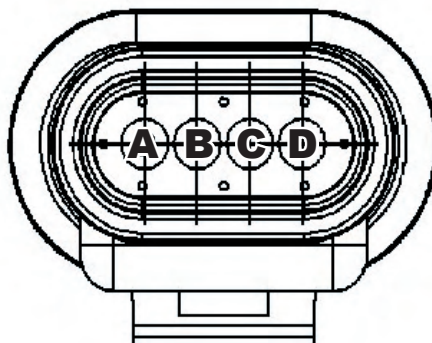

Pin	Wire Color	Function
A	Yellow/Black	Coil 2
B	Yellow	Coil 1
C	Black	Power Ground
D	Pink/Dk Green	Relay Fused Power

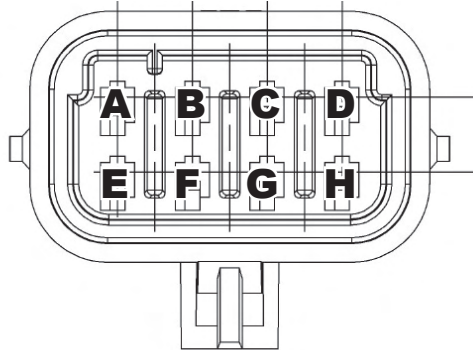
FUEL SYSTEM CONNECTOR C004

Pin	Wire Color	Function
A	Orange/Blue	INJ +
B	Brown/Blue	INJ 1
C	Brown/Green	INJ 2
D	White/Black	Fuel Lockoff
E	White/Red	Gaseous Trim
F	Pink/Tan	VSW
G	Red/White	INJ 7
H	not used	

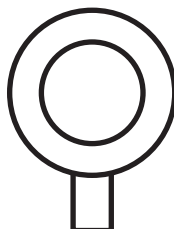
OIL PRESSURE CONNECTOR C005

Pin	Wire Color	Function
A	Lt Green/Black	Oil Pressure

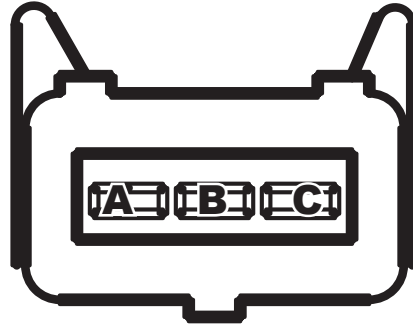
CRANK SENSOR CONNECTOR C006

Pin	Wire Color	Function
A	Black	Power Ground
B	Purple/White	Crank +
C	White/Purple	Crank -

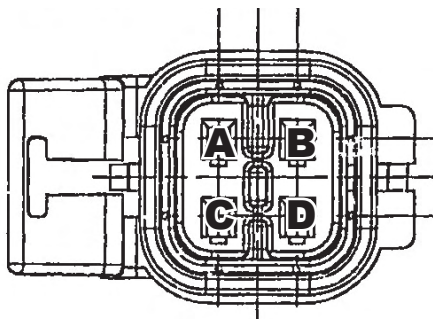
HEGO CONNECTOR C007

Pin	Wire Color	Function
A	Blk/Lt Green	Analog Return
B	Dk Green/Orange	EGO
C	Pink/Dk Green	Coil
D	Black	Power Ground

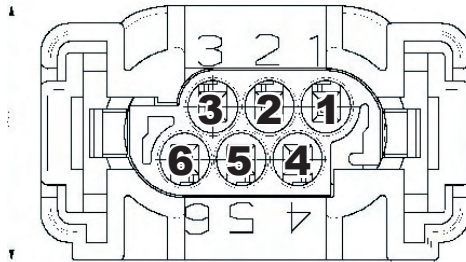
BOSCH THROTTLE CONNECTOR C008

Pin	Wire Color	Function
1	Tan/Orange	DBW -
2	Black/Lt Green	Analog Return
3	Lt Green/Red	5 Volt Reference
4	Pink/White	DBW +
5	Lt Blue/Dk Blue	TPS 2
6	Purple/Lt Blue	TPS 1

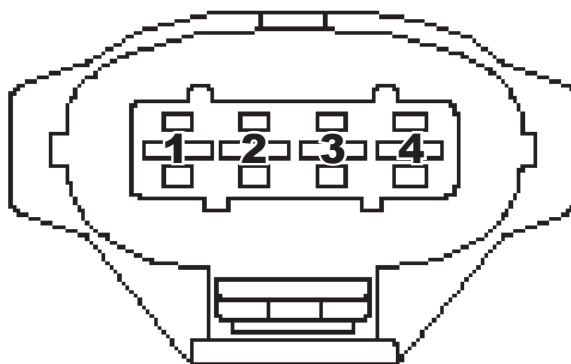
BOSCH TMAP CONNECTOR C009

Pin	Wire Color	Function
1	Black/Lt Green	Analog Return
2	Tan	IAT
3	Lt Green/Red	5 Volt Reference
4	Lt Green	MAP

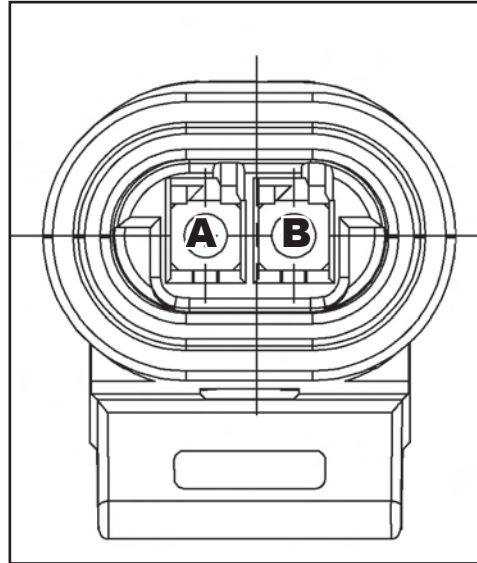
ENGINE COOLANT TEMPERATURE SENSOR CONNECTOR C010

Pin	Wire Color	Function
A	Yellow/Gray	Engine Coolant Temp
B	Black/Lt Green	Analog Return

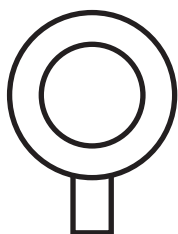
STARTER SOLENOID CONNECTOR C011

Pin	Wire Color	Function
A	White	Starter Relay

BATTERY CONNECTOR C012

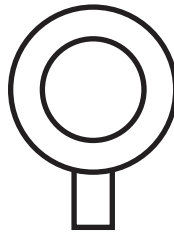

Pin	Wire Color	Function
A	Red	Battery +

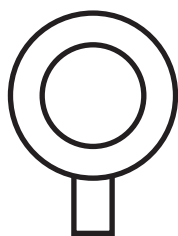
ALTERNATOR CONNECTOR C013

Pin	Wire Color	Function
A	Red	Battery +

BATTERY CONNECTOR C014

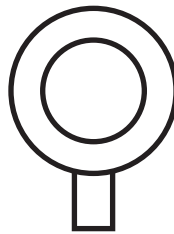

Pin	Wire Color	Function
A	Red	Battery +

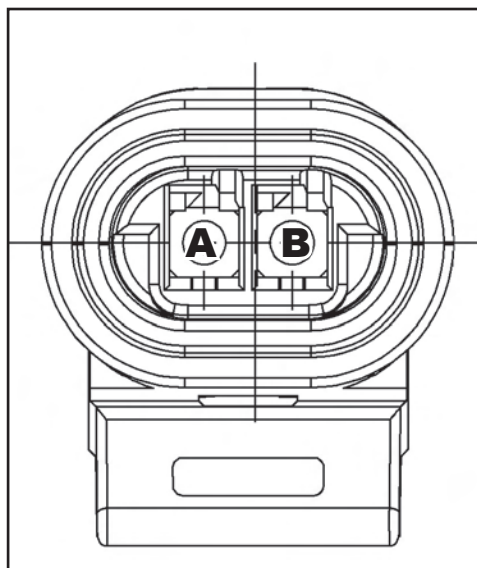
ALTERNATOR CONNECTOR C015

Pin	Wire Color	Function
A	Red	Battery
B	Pink/Dk Green	Power Relay

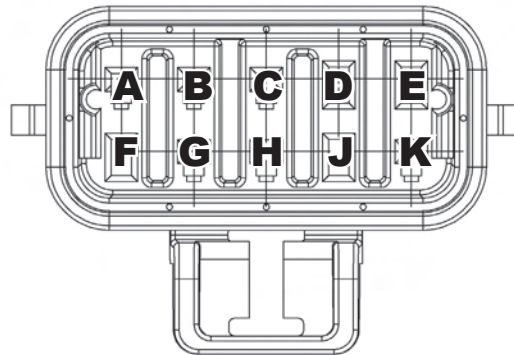
INSTRUMENT PANEL CONNECTOR C016

Pin	Wire Color	Function
A	Pink	VSW
B	Dk Blue	FPP1
C	Purple/Yellow	IVS
D	Black/Lt Green	Ana Return
E	Lt Green/Black	Oil Pressure
F	Lt Blue/Black	MIL
G	Lt Green/Red	VREF
H	Orange/Yellow	Charge Volts
J	Lt Blue/Pink	Start In (Interrupt Type)
K	Pink/Black	Start In (Autocranking)

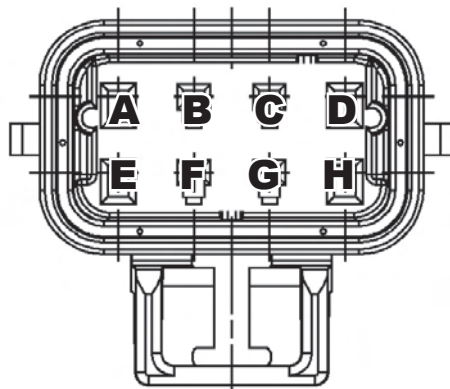
INSTRUMENT PANEL CONNECTOR C017

Pin	Wire Color	Function
A	Lt Blue/White	Aux Out 2A
B	Tan/Dk Green	Aux In PD1
C	Yellow/Lt Green	Tach
D	Tan/Brown	Fuel Select
E	Grey/Dk Blue	Gov Select
F	Blue/Pink	Can +
G	Blue/White	Can -
H	Purple/Dk Blue	Aux Out 1

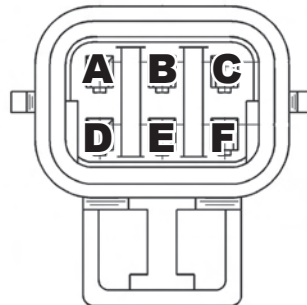
INSTRUMENT PANEL CONNECTOR C018

Pin	Wire Color	Function
A	Black/White	Aux In PD2
B	Yellow/Dk Blue	Aux In PU2
C	Dk Blue/Yellow	Aux In PU1
D	Pink/Yellow	Fuel Pump
E	Black	Ground
F	Pink/Dk Green	Relay Fused Power

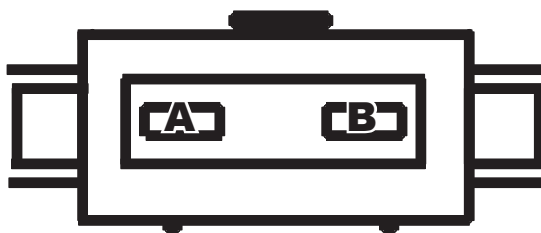
INJECTOR CONNECTOR C020

Pin	Wire Color	Function
A	Orange/Lt Blue	INJ +
B	Brown/Lt Blue	INJ 1

ALTERNATOR C021

Pin	Wire Color	Function
A	Orange/Blue	INJ +
C	Brown/Green	INJ 2

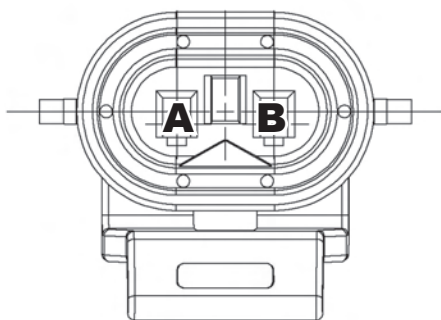
FUEL TRIM VALVE CONNECTOR C022

Pin	Wire Color	Function
A	Red/White	Injector 7
B	Orange/Lt Blue	Injector +

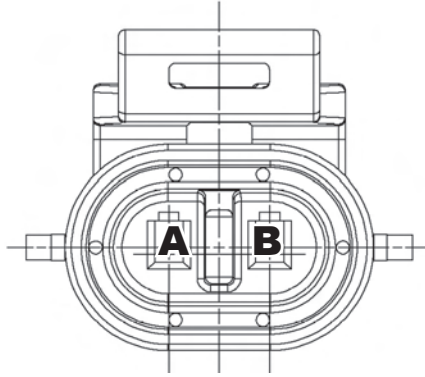
FUEL LOCK OFF CONNECTOR C023

Pin	Wire Color	Function
A	White/Black	Fuel Lockoff
B	Pink/Tan	VSW

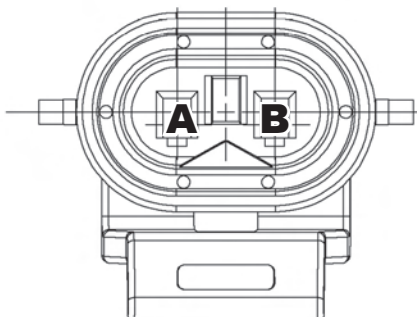
PRESSURE TRIM VALVE CONNECTOR C024

Pin	Wire Color	Function
A	White/Red	Fuel Trim
B	Orange/Lt Blue	INJ +

SECTION 1C4

DIAGNOSTIC TROUBLE CODES

Definition of Terms	1C4-2	DTC 511-COP Failure	1C4-92
Diagnostic Overview	1C4-3	DTC 512-Invalid Interrupt	1C4-94
Laptop Based Diagnostics	1C4-4	DTC 513-A/D Loss	1C4-96
Blink Code Based Diagnostics	1C4-11	DTC 514-RTI 1 Loss	1C4-98
MIL Operation Check	1C4-12	DTC 515-Flash Checksum Invalid	1C4-100
DTC 111-IAT High Voltage	1C4-16	DTC 516-RAM Failure	1C4-102
DTC 112-IAT Low Voltage	1C4-20	DTC 531-5V Ref Lower Than Expected	1C4-104
DTC 113-IAT Higher Than Expected 1	1C4-24	DTC 532-5V Ref Higher Than Expected	1C4-108
DTC 114-IAT Higher Than Expected 2	1C4-26	DTC 555-RTI 2 Loss	1C4-110
DTC 115-Oil Pressure Low	1C4-28	DTC 556-RTI 3 Loss	1C4-112
DTC 121-ECT High Voltage	1C4-32	DTC 631-TPS 1 Signal Voltage High	1C4-114
DTC 122-ECT Low Voltage	1C4-36	DTC 632-TPS 1 Signal Voltage Low	1C4-118
DTC 123-ECT Higher Than Expected 1	1C4-40	DTC 633-TPS2 Signal Voltage High	1C4-122
DTC 124-ECT Higher Than Expected 2	1C4-42	DTC 634-TPS 2 Signal Voltage Low	1C4-126
DTC 131-MAP High Pressure	1C4-44	DTC 635-TPS1 Higher Than TPS 2	1C4-130
DTC 132-MAP Low Voltage	1C4-48	DTC 636-TPS1 Lower Than TPS2	1C4-134
DTC 134-BP High Pressure	1C4-52	DTC 637-Throttle Unable To Open	1C4-138
DTC 135-BP Low Pressure	1C4-54	DTC 638-Throttle Unable To Close	1C4-142
DTC 142-Crank Sync Noise	1C4-58	DTC 651-Max Govern Speed Override	1C4-146
DTC 143-Never Crank Sync at Start	1C4-62	DTC 652-Fuel Rev Limit	1C4-148
DTC 211-C.L. Multiplier High (LPG)	1C4-64	DTC 653-Spark Rev Limit	1C4-150
DTC 212-HO2S Open/Inactive	1C4-68		
DTC 221-C.L. Multiplier High (Gasoline)	1C4-72		
DTC 222-C.L. Multiplier Low (Gasoline)	1C4-74		
DTC 224-C.L. Multiplier Low (LPG)	1C4-76		
DTC 241-Adaptive Lean Fault (Gasoline)	1C4-78		
DTC 242-Adaptive Rich Fault (Gasoline)	1C4-82		
DTC 243-Adaptive Learn High (LPG)	1C4-84		
DTC 244-Adaptive Learn Low (LPG)	1C4-86		
DTC 261-Sytem Voltage Low	1C4-90		
DTC 262-System Voltage High	1C4-88		

DESCRIPTION OF ECM BASED DIAGNOSTICS

DEFINITION OF TERMS

Active Gov Mode	Speed is governed by one of two modes. Isochronous, which maintains an exact speed, or Droop, which allows speed to drop a predetermined amount based on current engine load.
AL	Adaptive Learn
AL Mult	Adaptive Learn Multiplier. The adaptive learn multiplier is a correction to the fuel delivery which is expressed as a percentage (%) and stored in the ECM's RAM.
Analog	0 to 5 volt or 0 to 12 volt signals
Batt	Battery Voltage
BP	Barometric Pressure. The pressure of the outside air.
CHT	Cylinder Head Temperature
CL	Closed Loop
CL Mult	Closed Loop Multiplier. The closed loop multiplier is a fast acting adjustment to the fuel delivery based on feedback from the HEGO. The closed loop multiplier is expressed as a percentage (%) and is not stored in the ECM's memory.
Closed Loop	Fuel and timing modified based on feedback from the O2 sensor.
DBW	Drive by wire.
DTC	Diagnostic Trouble Code. A code which is stored in the ECM when an ECM initiated test fails.
ECT	Engine Coolant Temperature.
ECM	Engine Control Module. The computer, which controls the fuel and ignition system on the engine.
EGO	See HO2S
FPP	Foot Pedal Position.
HO2S	Heated Oxygen Sensor
IAT	Intake Air Temperature
IVS	Idle Validation Switch
MAP	Manifold Absolute Pressure. The pressure of the air in the intake manifold.
MAT	Manifold Air Temperature. The temperature of the air in the intake manifold
MIL	Malfunction Indicator Light. A dash mounted light that illuminates when the ECM senses a system fault.
ms	Milli-seconds. 1/1000 of a second.
Open Loop	Fuel and timing based strictly on tables stored in the ECM.
PSIA	Pounds per square inch absolute. 14.7 psia = 0 psig
RAM	Random Access Memory. The portion of computer memory within the ECM, which changes as the engine is running and is stored while the engine is off.
TPS	Throttle Position Sensor. The throttle position sensor measures the opening of the throttle.

DIAGNOSTICS OVERVIEW OF THE ENGINE CONTROL SYSTEM

The Engine Control System has built-in diagnostics for trouble shooting. The system accommodates a dash mounted Malfunction Indicator Lamp (MIL) for indication of system problems (OEM specified).

MALFUNCTION INDICATOR LAMP (MIL)

Most engine control system related problems that affect emissions or driveability of the vehicle will set a (DTC) Diagnostic Trouble Code and illuminate the Malfunction Indicator Lamp.

The MIL has the following functions:

1. It notifies the driver of a problem with the fuel system, ignition system, or emission control system so the driver can arrange for service as soon as possible.
2. It will display DTC's that have been stored due to a system malfunction.

The lamp should come on when the key is in the ON position and the engine is not running. This feature verifies that the lamp is in proper working order. If the lamp does not come on with the vehicle key on/engine off, repair it as soon as possible. Once the engine is in start or run mode, the lamp should go off. If the lamp illuminates while the engine is in the start or run mode, there is a current Diagnostic Trouble Code.

Diagnostic Trouble Codes (DTC)

Diagnostic Trouble Codes are set when the ECM (Electronic Control Module) runs a diagnostic self-test and the test fails. When a DTC is set, the ECM will illuminate the Malfunction Indicator Lamp on the instrument panel and save the code in memory. The ECM will continue to run the self-test unless the DTC is an oxygen sensor lean, oxygen sensor rich, or an internal ECM related DTC. If the system continues to fail the test, the lamp will stay illuminated and the DTC is current (ACTIVE). All DTC's are stored as historical faults until they are cleared. All DTC's except the ECM related DTC's will automatically clear from memory if the DTC does not reset within 50 consecutive engine run cycles.

While a Diagnostic Trouble Code is current for a sensor, the ECM may assign a default "limp home" value and use that value in its control algorithms. All of the system diagnostic self-tests run continuously during normal vehicle operation.

The Diagnostic Trouble Codes can be read by using either the MIL lamp or a laptop computer. Refer to *Laptop Based Diagnostics* and *Blink Code Based Diagnostics*, located in this section. Diagnostic Trouble Codes can be cleared from memory with a laptop computer or by turning the ignition key to the OFF position and removing the system main power fuse (F3) for 15 seconds.

If more than one DTC is detected, always begin with the **lowest number DTC** and diagnose each problem to correction unless directed to do otherwise by the fault tree. The DTC's are numbered in order of importance. Having DTC 112 and DTC 122, both concerning the oxygen sensor, is possible. By repairing DTC 112 first, the problem causing the DTC 122 may also be corrected.

USING A LAPTOP COMPUTER TO DIAGNOSE THE ENGINE CONTROL SYSTEM

A laptop computer is the preferred tool for performing diagnostic testing of the system. A laptop computer, with the system diagnostic cable and diagnostic software, is used to read and clear Diagnostic Trouble codes. It is also used to monitor sensor and actuator values. The diagnostic software also performs several special tests.

The following procedures will assist you in using a laptop computer to diagnose the system:

INSTALLING THE DIAGNOSTIC SOFTWARE

Loading Software and Connecting the Computer

- Start Windows
- Insert the Diagnostic Interface software CD.
- Click on the **START** button.
- From the Start menu, select **RUN**.
- In the command-line text box, type the letter of your CD-ROM drive, followed by: **\setup** (for example, **e:\setup**), then click **OK**.
- Follow the on screen instructions.

Connecting a Laptop Computer to the Spectrum System

- Connect the system diagnostic cable to the RS232 port on the back of the computer. If you do not have a RS-232 port use the USB to RS232 adapter cable.
- Connect the diagnostic cable to the diagnostic connector on the engine harness. The diagnostic connector is a square 4-pin connector located near the ECM.
- Turn the computer ON.
- Start Windows.
- From the **Start** menu select **Programs**.
- Select **PSI Display** and enter password.
- Place the ignition key in the ON position.
- The system Gauge screen should now appear and a green banner in the upper left hand will read "Connected".

DIAGNOSTIC TROUBLE CODES

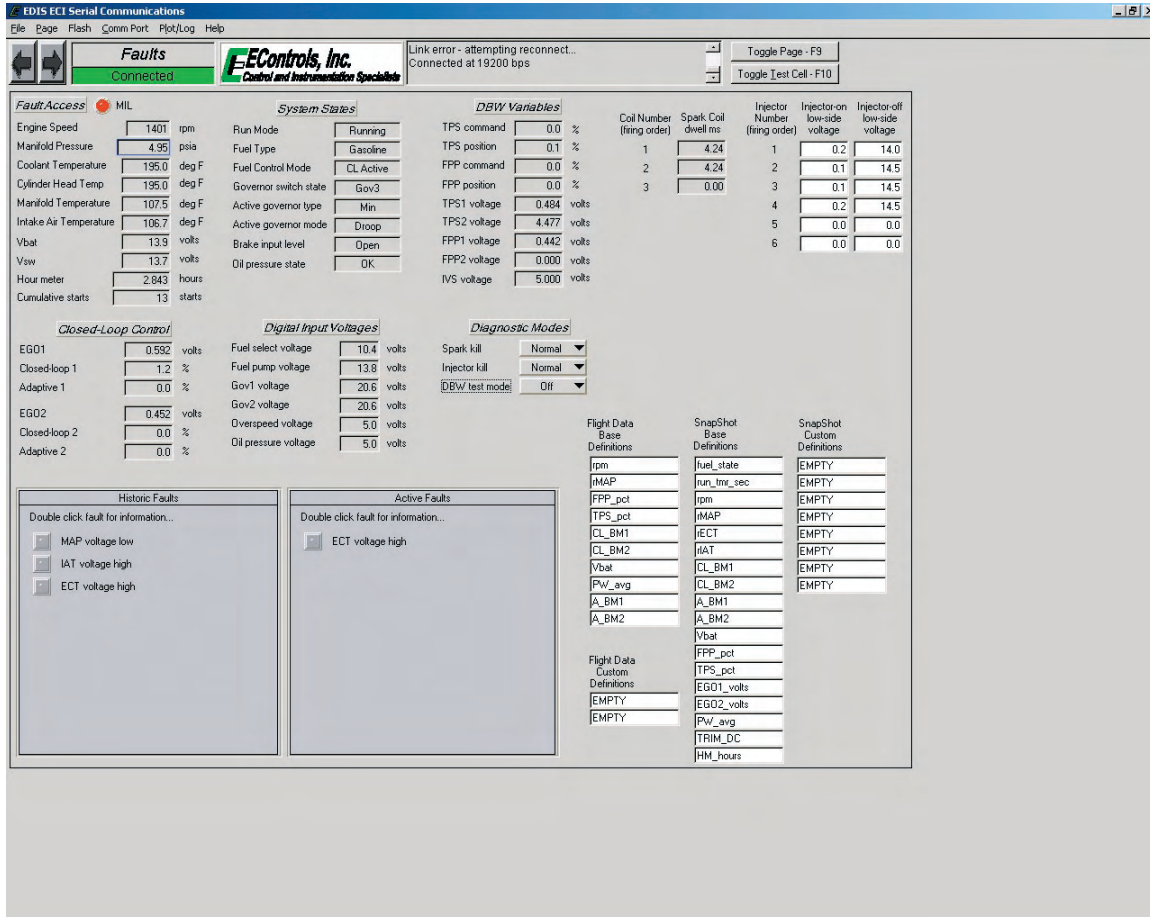

The System Fault screen is used to view and clear DTC's, which have been set.

Checking Diagnostic Trouble Codes

The System Fault screen contains a listing of all of the Historic and Active DTC's set within the system. If a DTC is stored in memory, the screen will display that fault in the History column. If the fault is active it will also show up in that column.

Clearing Diagnostic Trouble Codes

To clear a DTC from memory use the arrow keys or mouse to move the Press the Enter key to clear the fault from memory. **NOTE:** Record faults before erasing them for reference during diagnostics.

DATA STREAM

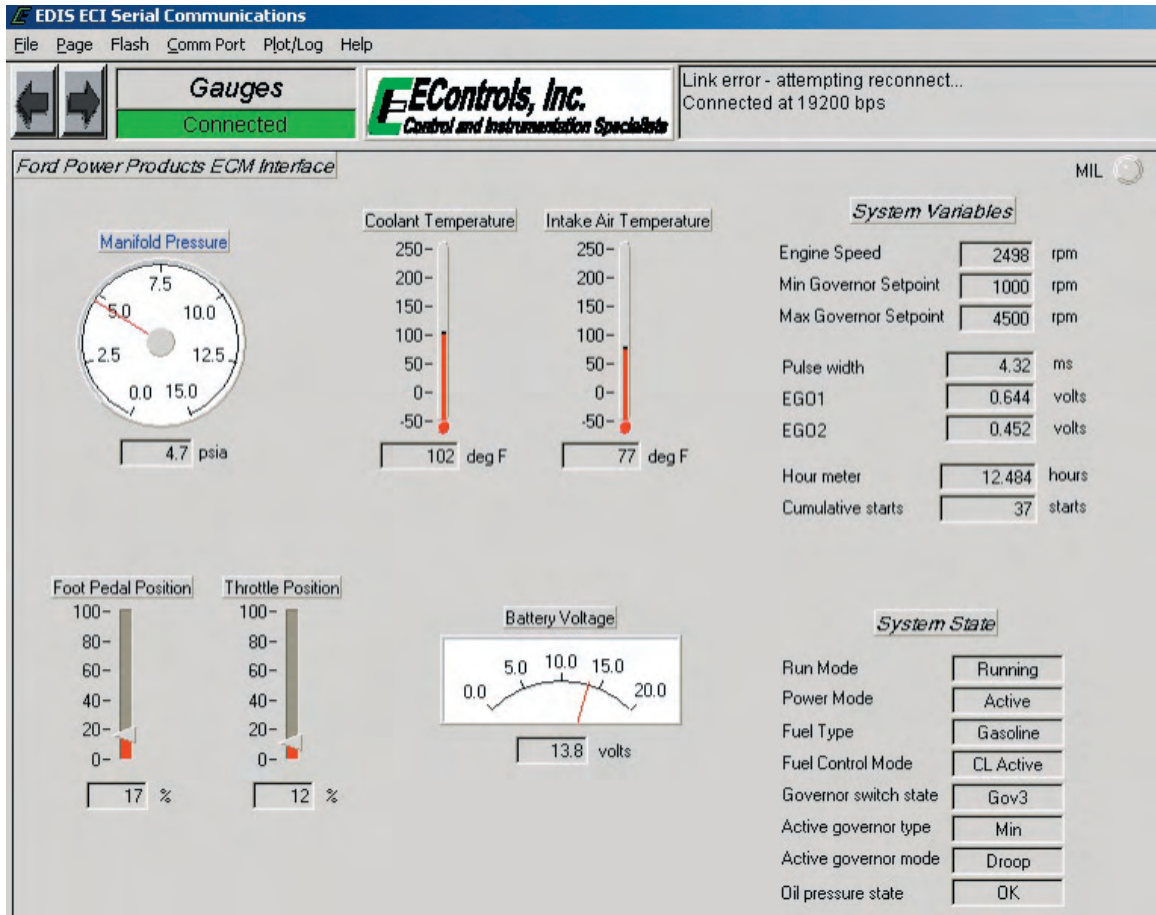

Reading Sensor and Actuator Values

Most applicable sensor and actuator values are displayed on the Gauges screen. The display shows the value for sensors, voltages and the sensor values in engineering units.

NOTE: If a DTC for a sensor is current, the engineering value for that sensor may be a default, limp home value and the voltage value will be the actual sensor voltage. Use the voltage value when performing diagnostics unless directed to do otherwise by the diagnostic trouble tree.

Graphing and Data Logging

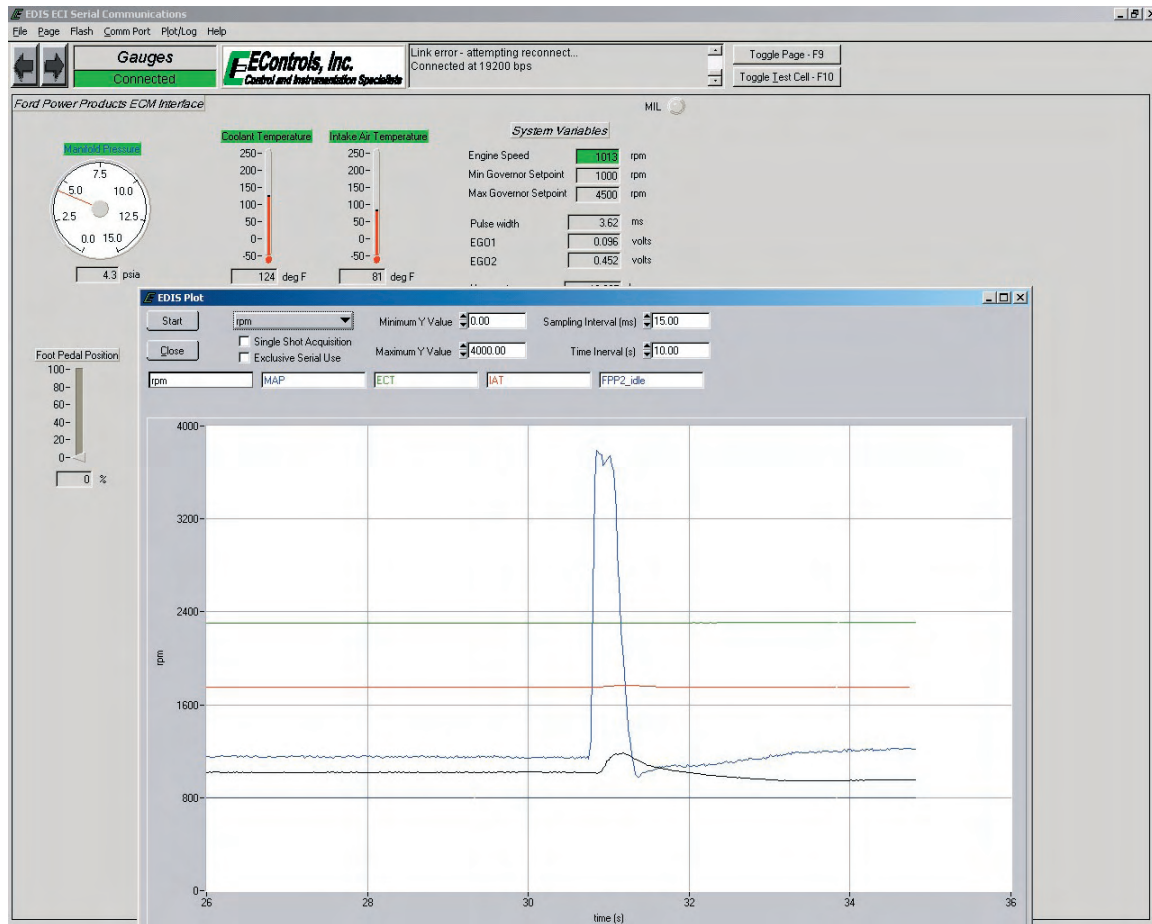

Graphing the values and voltages can be a very useful tool in doing intermittent diagnosis. The system diagnostic monitoring software includes graphing and data logging capability. These features enhance the ability to diagnose and repair possible problems with the system. The graphing feature allows sensor inputs and select control output variables to be plotted in real-time while the engine is running.

To plot a variable you must first “TAG” the variable you wish to plot. To do this, use the mouse to highlight the variable, and then right click.

Next press the “P” key or double click the Plot/Log button to invoke the plotting feature. You may change the desired time interval for each display screen. The default is 10 seconds. This can be increased or decreased as necessary to display the desired results. You can also change the sample rate.

You are now ready to plot. Simply click the “START” button to observe the plotted variables. The plot sweeps across the screen from left to right. To pause the display screen press the “SPACE BAR” at any time during plotting. To continue plotting simply press the “SPACE BAR” again. To stop the plotting feature simply click the “STOP” button. To exit the plotting screen click the “CLOSE” button. The range of each variable is listed along the left side of the display and the time is listed along the bottom of the screen.

IGNITION SYSTEM TEST

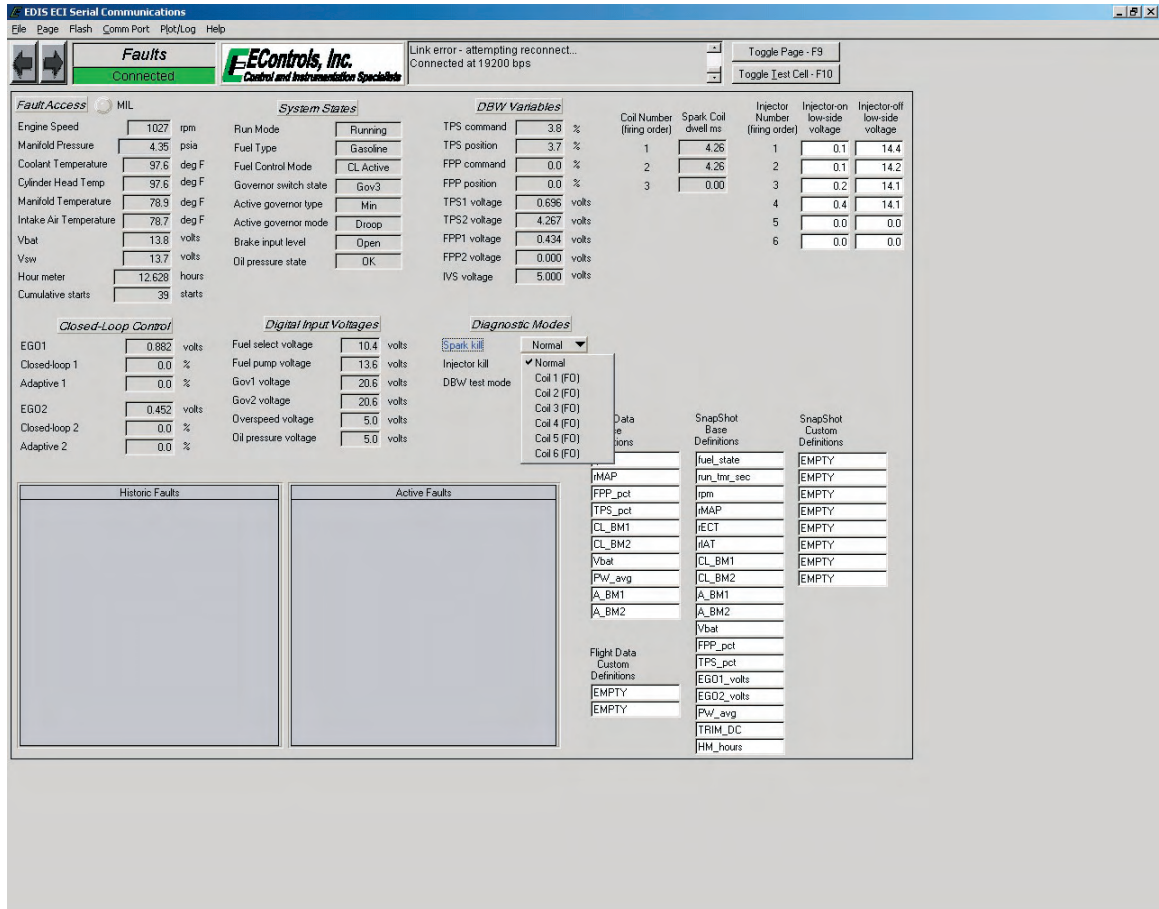

The Spark Kill diagnostic mode allows the technician to disable the ignition on individual cylinders. If the Spark Kill diagnostic mode is selected with the engine running below 1000 RPM, the minimum throttle command will lock into the position it was in when the test mode was entered. If the Spark System Test mode is selected with the engine running above 1000 RPM, the throttle will continue to operate normally.

Disabling Ignition Outputs

To disable the ignition system for an individual cylinder, use the mouse to highlight the “Spark Kill” button and select the desired coil. The spark output can be re-enabled by using the mouse to highlight the “Spark Kill” button and selecting “Normal”. If the engine is running below 1000 RPM, the spark output will stay disabled for 15 seconds and then re-set. If the engine is running above 1000 RPM, the spark output will stay disabled for 5 seconds and then re-set. This test mode has a timeout of 10 minutes. Record the rpm drop related to each spark output disabled.

The Spark outputs are arranged in the order which the engine fires, not by cylinder number.

INJECTOR TEST

The screenshot displays the EDIS ECI Serial Communications software interface. At the top, it shows 'Faults' as 'Connected' and 'EControls, Inc. Control and Instrumentation Specialists'. A status bar indicates 'Link error - attempting reconnect... Connected at 19200 bps'. The main interface is divided into several sections:

- Fault Access:** MIL (selected)
- System States:** Run Mode (Running), Fuel Type (Gasoline), Fuel Control Mode (CL Active), Governor switch state (Gov3), Active governor type (Min), Active governor mode (Disoop), Brake input level (Open), Oil pressure state (OK).
- DBW Variables:** TPS command (3.3%), TPS position (3.5%), FPP command (0.0%), FPP position (0.0%), TPS1 voltage (0.685 volts), TPS2 voltage (4.275 volts), FPP1 voltage (0.448 volts), FPP2 voltage (0.000 volts), IVS voltage (5.000 volts).
- Coil Number (firing order):** 1 (4.25), 2 (4.25), 3 (0.00).
- Spark Coil dwell ms:** 1 (0.3), 2 (0.1), 3 (0.4), 4 (0.2), 5 (0.0), 6 (0.0).
- Injector Number (firing order):** 1 (0.3), 2 (0.1), 3 (0.4), 4 (0.2), 5 (0.0), 6 (0.0).
- Injector-on low-side voltage:** 1 (0.3), 2 (0.1), 3 (0.4), 4 (0.2), 5 (0.0), 6 (0.0).
- Injector-off low-side voltage:** 1 (14.2), 2 (14.1), 3 (14.0), 4 (14.4), 5 (0.0), 6 (0.0).
- Closed-Loop Control:** EG01 (0.503 volts), EG02 (0.452 volts), Closed-loop 1 (4.5%), Adaptive 1 (0.0%), Closed-loop 2 (0.0%), Adaptive 2 (0.0%).
- Digital Input Voltages:** Fuel select voltage (10.2 volts), Fuel pump voltage (13.7 volts), Gov1 voltage (20.6 volts), Gov2 voltage (20.6 volts), Overspeed voltage (5.0 volts), Oil pressure voltage (5.0 volts).
- Diagnostic Modes:** Spark kill (Normal), Injector kill (Normal), DBW test mode (Normal).
- Historic Faults:** (Empty panel)
- Active Faults:** (Empty panel)
- Flight Data Custom Definitions:** FPP_pct, TPS_pct, CL_BM1, CL_BM2, Vbat, FW_avg, A_BM1, A_BM2, FPP_pct, TPS_pct, EG01_volts, EG02_volts, FW_avg, TRIM_DC, HM_hours.

The Injector Kill mode is used to disable individual fuel injectors. If the Injector Kill mode is selected with the engine running below 1000 RPM, the minimum throttle command will lock into the position it was in when the test mode was entered. If the Injector Kill mode is selected with the engine running above 1000 RPM, the throttle will continue to operate normally.

Disabling Injectors

To disable an injector, use the mouse to select the desired. The word "Normal" will change to the Injector you have selected. The injector driver can be re-enabled by selecting again. If the engine is running below 1000 RPM, the injector driver will stay disabled for 15 seconds and then re-set. If the engine is running above 1000 RPM, the injector driver will stay disabled for 5 seconds and then re-set. Record the change in rpm or closed loop multiplier while each driver is disabled.

Using a Diagnostic Jumper to Diagnose the ECI System

If you do not have access to a laptop computer, it is still possible to access the Diagnostic Trouble Codes stored in the memory of the ECM using a diagnostic jumper and the Malfunction Indicator Lamp. With the key off connect the diagnostic jumper to the ECI system diagnostic connector located near the ECM. The jumper will connect diagnostic pins A and D. Turn the ignition on but do not start the vehicle. The Malfunction Indicator Lamp (MIL) will begin to flash.

The MIL displays three digit codes by flashing the first digit, pausing, then flashing the second digit, pausing, and then flashing the third digit. There will be a long pause between codes. For example, a code 143 would be one flash followed by four flashes followed by three flashes.

The MIL will first display a 166 three times. Code 166 indicates that the ECM based diagnostic routines are functioning. Then, any Diagnostic Trouble Codes stored in memory will display three times each. The MIL will then start over with the code 166. If the vehicle is started while the diagnostic jumper is in place, the MIL will flash rapidly.

Diagnostic Trouble Codes may be cleared from the system ECM memory by moving the ignition key to the OFF position and removing the (F1) system battery fuse for at least 15 seconds. **Note:** This will erase all of the memory in the computer including the adaptive learn.

OBD System Check/Malfunction Indicator Lamp

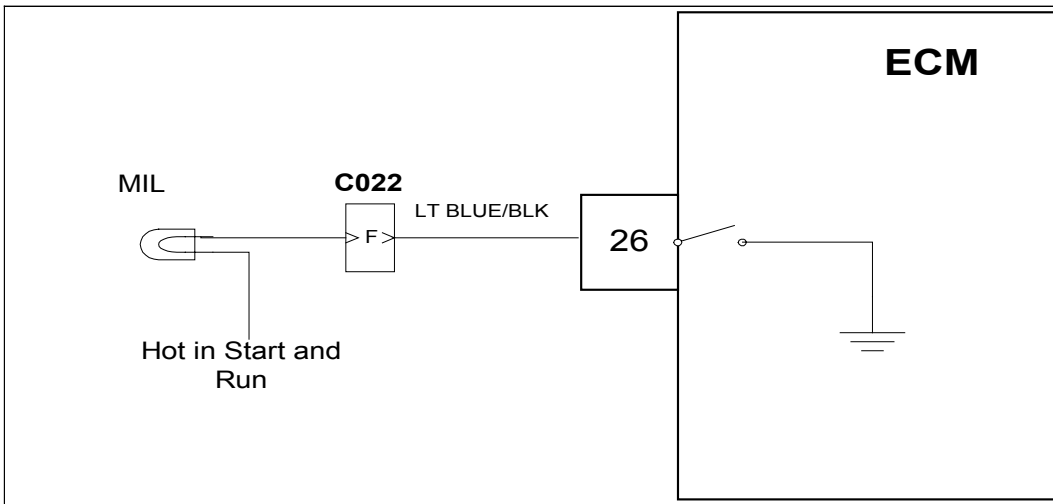

Circuit Description

The engine control system is equipped with OBD (On-Board Diagnostics). The system has a dash mounted MIL (Malfunction Indicator Lamp) for the indication of system problems. Engine control system problems that affect emissions or driveability of the vehicle will set a DTC (Diagnostic Trouble Code). The ECM will then provide a path to ground and illuminate the MIL (Malfunction Indicator Lamp)

The MIL has the following functions:

1. It notifies the driver of a problem with the fuel system, ignition system, or emission control system so the driver can arrange for service as soon as possible.
2. It will display DTC's that have been stored due to a system malfunction.

The lamp should illuminate when the key is in the ON position, and the engine is not running. This feature verifies that the lamp is in proper working order. If the lamp does not come on with the vehicle key on/engine off, repair it as soon as possible. Once the engine is in start or run mode, the lamp should go off. If the lamp illuminates while the engine is in the start or run mode, a current Diagnostic Trouble Code may be set. Always use the OBD System Check chart on the next page of this manual to verify proper MIL operation before proceeding with a DTC diagnostic code repair.

OBD System Check

	Action	Value(s)	Yes	No
1	<ul style="list-style-type: none"> Key ON Engine OFF Does the MIL illuminate?		Go to Step (2)	Go to Step (3)
2	<ul style="list-style-type: none"> Start the engine Does the MIL lamp turn off? 		MIL is working properly. OBD System Check is complete	Go to Step (10)
3	<ul style="list-style-type: none"> Key ON engine OFF Check for voltage between MIL power source and engine ground Do you have voltage?		Go to Step (4)	Repair MIL voltage source. Refer to OEM body and chassis wiring diagrams
4	Replace MIL lamp Did that solve the problem?		Go to step (1)	Go to Step (5)
5	<ul style="list-style-type: none"> Key OFF Disconnect ECM wire harness connector C001 Using a DVOM check for continuity between MIL ground and ECM terminal 26 Do you have continuity?		Go to Step (6)	Go to Step (8)
6	<ul style="list-style-type: none"> Inspect the MIL lamp socket, connector C022 and ECM terminal 26 for damage, corrosion or contamination Did you find a problem?		Repair the circuit as necessary. Refer to Wiring Repairs in Engine Electrical.	Go to Step (7)
7	<ul style="list-style-type: none"> Replace ECM Is the replacement complete?		Go to Step (1)	-
8	<ul style="list-style-type: none"> Back probe the MIL and ECM terminal F in connector C022 Using a DVOM check for continuity through connector C022 Do you have continuity?		Go to Step (9)	Go to Step (9)
9	<ul style="list-style-type: none"> Inspect the MIL lamp socket, connector C022 and ECM terminal 26 for damage, corrosion or contamination Did you find a problem?		Repair the open circuit as necessary. Refer to Wiring Repairs in Engine Electrical.	Repair the open circuit as necessary. Refer to Wiring Repairs in Engine Electrical.

10	Active DTC (Diagnostic trouble code) is stored in memory. Proceed with DTC diagnosis. If no active DTC is found in ECM memory return to this page Step (11)		-	-
11	<ul style="list-style-type: none">• Key OFF• Disconnect ECM wire harness connector C001• Using a DVOM check for continuity between ECM terminal 26 and battery voltage• Do you have continuity?		Repair the shorted to ground circuit as necessary. Refer to Wiring Repairs in Engine Electrical.	Go to Step (7)

DTC 111-IAT High Voltage (Bosch TMAP)

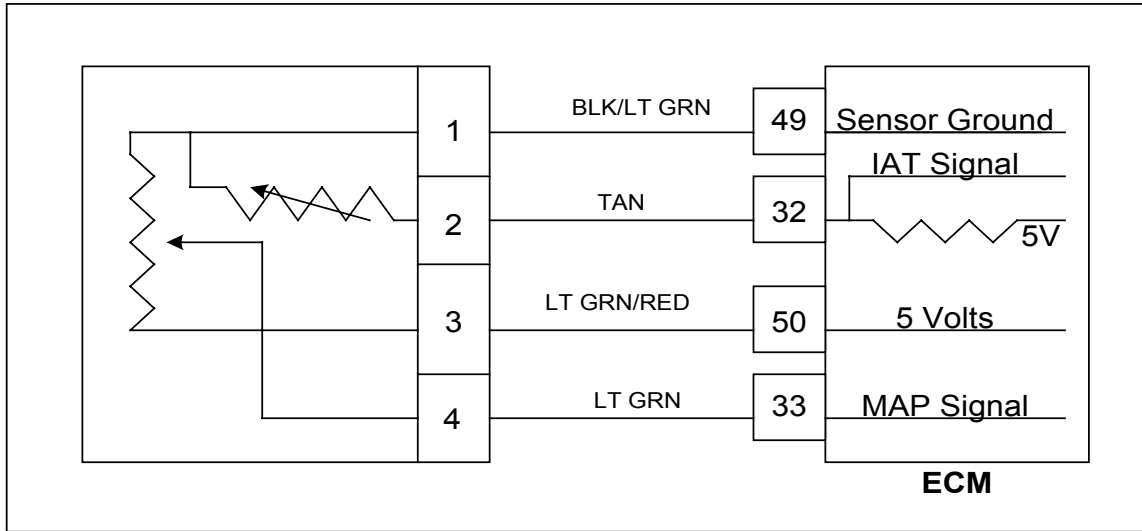

Conditions for Setting the DTC

- Intake Air Temperature
- Check Condition-Engine Running
- Fault Condition-IAT Sensor Voltage greater than 4.95
- MIL-On during active fault and for 2 seconds after active fault
- Adaptive-Disabled during active fault
- Closed Loop-Enabled

Circuit Description

The TMAP is a combined IAT (Intake Air Temperature) and MAP (Manifold Absolute Pressure) sensor. A temperature sensitive resistor is used in the TMAP located in the intake manifold of the engine. It is used to monitor incoming air temperature, and the output in conjunction with other sensors is used to determine the airflow to the engine. The ECM provides a voltage divider circuit so that when the air is cool, the signal reads higher voltage, and lower when warm.

The IAT is a calculated value based mainly on the IAT sensor at high airflow, and influenced more by the ECT (Engine Coolant Temperature) at low airflow.

This fault will set if the signal voltage is more than 4.95 volts anytime the engine is running. The ECM will use the default value for the IAT sensor in the event of this fault.

DTC 111- IAT VOLTAGE HIGH (BOSCH TMAP)

	Action	Value(s)	Yes	No
1	Did you perform the On-Board (OBD) System Check?	-	Go to Step (2)	Go to OBD System Check Section
2	<ul style="list-style-type: none"> • Key On • DST (Diagnostic Scan Tool) connected in System Data Mode Does DST display IAT voltage of 4.95 or greater?		Go to step (3)	Intermittent problem Go to Intermittent section
3	<ul style="list-style-type: none"> • Key Off • Disconnect the TMAP sensor connector from the wiring and harness and jumper pins 1 and 2 together • Key On Does the DST display IAT voltage of 0.1 volts or less?		Go to step (9)	Go to step (4)
4	<ul style="list-style-type: none"> • Key OFF • Jumper TMAP sensor connector signal pin 2 to engine ground • Key ON • Does DST display IAT voltage of 0.1 volts or less? 		Go to Step (7)	Go to Step (6)
5	Replace TMAP sensor. Is the replacement complete?		Go to Step (11)	—
6	<ul style="list-style-type: none"> • Key OFF • Disconnect the ECM wire harness connector. • Check for continuity between TMAP sensor connector signal pin 2 and ECM IAT signal pin 32. Do you have continuity between them?	—	Go to step (10)	Repair the circuit as necessary. Refer to Wiring Repairs in Engine Electrical.
7	<ul style="list-style-type: none"> • Check for continuity between TMAP sensor connector ground circuit pin 1 and ECM sensor ground circuit pin 49. Do you have continuity between them?	—	Go to step (10)	Repair the circuit as necessary. Refer to Wiring Repairs in Engine Electrical.
8	Replace ECM. Refer to ECM replacement in the Engine Controls Section. Is the replacement complete?	—	Go to step (11)	—

9	<ul style="list-style-type: none"> • Re-check wire harness and TMAP sensor connectors for damage corrosion or contamination <p>Were any problems found?</p>		<p>Repair the circuit as necessary. Refer to Wiring Repairs in Engine Electrical</p>	<p>Go to Step (5)</p>
10	<ul style="list-style-type: none"> • Re-check wire harness and TMAP sensor connectors for damage corrosion or contamination <p>Were any problems found?</p>		<p>Repair the circuit as necessary. Refer to Wiring Repairs in Engine Electrical</p>	<p>Go to Step (8)</p>
11	<ul style="list-style-type: none"> • Remove all test equipment except the DST. • Connect any disconnected components, fuses, etc. • Using the DST clear DTC information from the ECM. • Turn the ignition OFF and wait 30 seconds. • Start the engine and operate the vehicle to full operating temperature • Observe the MIL • Observe engine performance and driveability • After operating the engine within the test parameters of DTC-111 check for any stored codes. <p>Does the engine operate normally with no stored codes?</p>		<p>System OK</p>	<p>Go to OBD System Check</p>

DTC 112-IAT Low Voltage (Bosch TMAP)

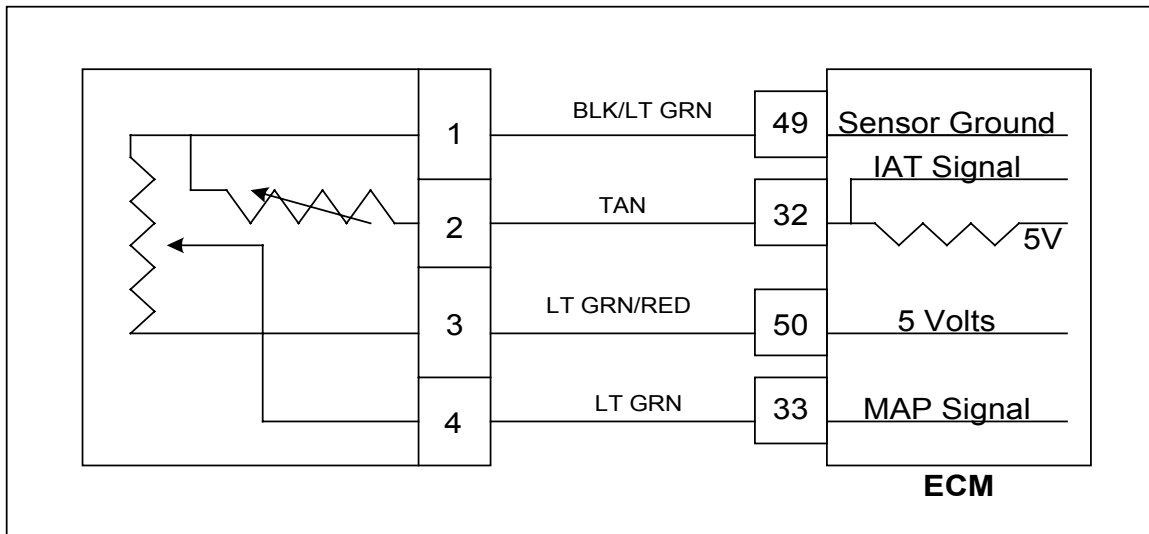

Conditions for Setting the DTC

- Intake Air Temperature
- Check Condition Engine Cranking or Running
- Fault Condition-IAT Sensor Voltage less than 0.05
- MIL-On during active fault and for 2 seconds after active fault
- Adaptive-Disabled during active fault
- Closed Loop-Enabled and allowed to stay at limit if required but will then also set the limiting fault.

Circuit Description

The TMAP is a combined IAT (Intake Air Temperature) and MAP (Manifold Absolute Pressure) sensor. A temperature sensitive resistor is used in the TMAP located in the intake manifold of the engine. It is used to monitor incoming air temperature, and the output in conjunction with other sensors is used to determine the airflow to the engine. The ECM provides a voltage divider circuit so that when the air is cool, the signal reads higher voltage, and lower when warm.

The IAT is a calculated value based mainly on the IAT sensor at high airflow, and influenced more by the ECT (Engine Coolant Temperature) at low airflow.

This fault will set if the signal voltage is less than 0.05 volts anytime the engine is cranking or running. The ECM will use the default value for the IAT sensor in the event of this fault.

DTC 112- IAT VOLTAGE LOW (BOSCH TMAP)

Step	Action	Value(s)	Yes	No
1	Did you perform the On-Board (OBD) System Check?	—	Go to Step (2)	Go to OBD System Check Section
2	<ul style="list-style-type: none"> • Key On • DST (Diagnostic Scan Tool) connected in System Data Mode Does DST display IAT voltage of 0.05 or less?		Go to step (3)	Intermittent problem Go to Intermittent section
3	<ul style="list-style-type: none"> • Key Off • Disconnect the TMAP sensor wire harness connector • Key ON Does the DST display IAT voltage of 4.9 volts or greater?		Go to step (4)	Go to step (5)
4	Replace TMAP sensor. Is the replacement complete?		Go to Step (9)	—
5	<ul style="list-style-type: none"> • Key OFF • Disconnect ECM wire harness connector. • Check for continuity between TMAP sensor connector ground pin 1 and TMAP sensor connector signal pin 2 Do you have continuity between them?	—	Repair the circuit as necessary. Refer to Wiring Repairs in Engine Electrical.	Go to step (6)
6	<ul style="list-style-type: none"> • Check for continuity between TMAP sensor connector signal circuit pin 2 and engine ground. Do you have continuity?	—	Repair the circuit as necessary. Refer to Wiring Repairs in Engine Electrical.	Go to step (7)
7	Replace ECM. Refer to ECM replacement in the Engine Controls Section. Is the replacement complete?	—	Go to step (8)	—

8	<ul style="list-style-type: none">• Remove all test equipment except the DST.• Connect any disconnected components, fuses, etc.• Using the DST clear DTC information from the ECM.• Turn the ignition OFF and wait 30 seconds.• Start the engine and operate the vehicle to full operating temperature• Observe the MIL• Observe engine performance and driveability• After operating the engine within the test parameters of DTC-112 check for any stored codes. Does the engine operate normally with no stored codes?		System OK	OBD System Check
---	--	--	-----------	------------------

DTC 113-IAT Higher Than Expected 1 (Bosch TMAP)

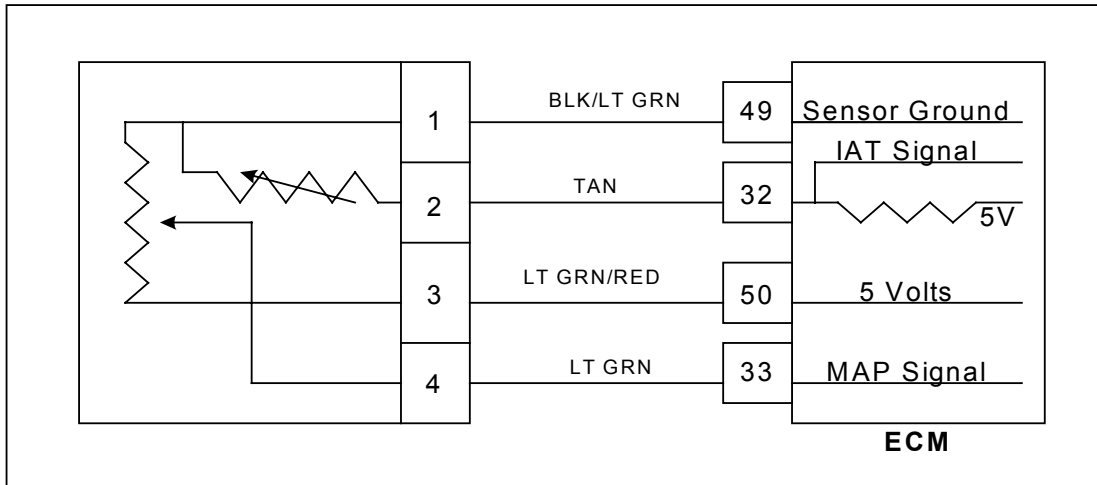

Conditions for Setting the DTC

- Intake Air Temperature
- Check Condition-Engine Running
- Fault Condition-Intake Air Temperature greater than 200 degrees F. and engine RPM greater than 1000
- MIL-Will flash at 2 Hz (twice per second) during active fault
- Adaptive-Disabled during active fault
- Closed Loop-Enabled
- Power Derate (Level 1)

Circuit Description

The TMAP is a combined IAT (Intake Air Temperature) and MAP (Manifold Absolute Pressure) sensor. A temperature sensitive resistor is used in the TMAP located in the intake manifold of the engine. It is used to monitor incoming air temperature, and the output in conjunction with other sensors is used to determine the airflow to the engine. The ECM provides a voltage divider circuit so that when the air is cool, the signal reads higher voltage, and lower when warm.

The IAT is a calculated value based mainly on the IAT sensor at high airflow, and influenced more by the ECT (Engine Coolant Temperature) at low airflow.

This fault will set if the Intake Air Temperature is greater than 210 degrees F. and engine RPM is greater than 1000 and Power Derate 1 will be enforced. During this fault, maximum throttle position is 50% and the MIL light will flash twice per second.

DTC 113-IAT Higher Than Expected 1 Bosch TMAP

Diagnostic Aids

* This fault will set when inlet air is much hotter than normal. The most common cause of high inlet air temperature is a problem with the inlet air system. Ensure that the air inlet is not obstructed, modified or damaged.

* Inspect the air inlet system for cracks or breaks that may allow unwanted under hood air in to the air inlet system

- If none of the above can be found, Follow the diagnostic steps for DTC 112-IAT Low Voltage Bosch TMAP.

DTC 114-IAT Higher Than Expected 2 (Bosch TMAP)

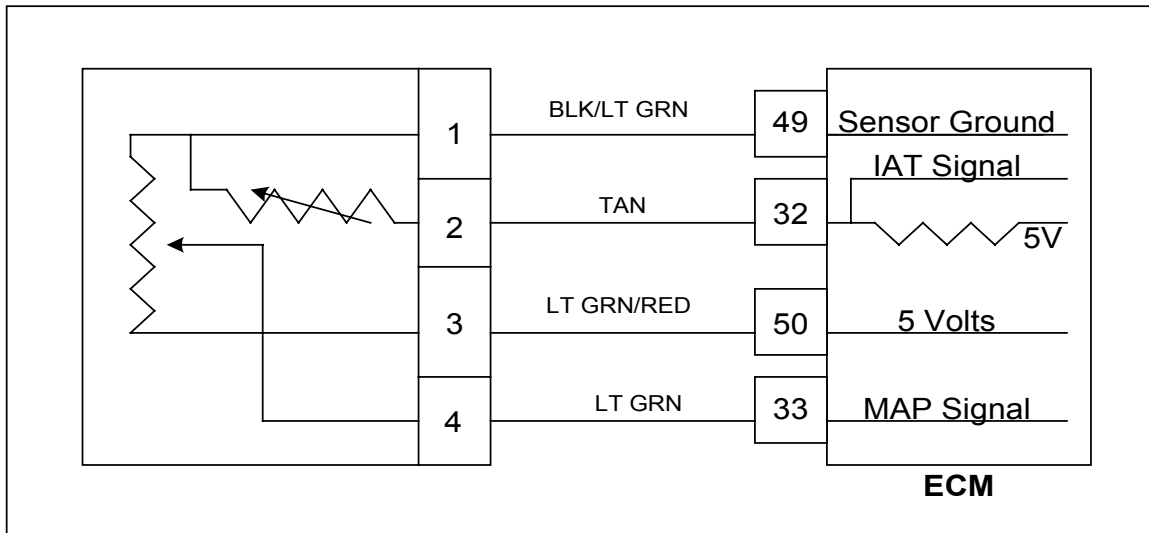

Conditions for Setting the DTC

- Intake Air Temperature
- Check Condition-Engine Running
- Fault Condition-Intake Air Temperature greater than 210 degrees F. and engine RPM greater than 1000
- MIL-On for active fault and for 15 seconds after active fault
- Adaptive-Disabled during active fault
- Closed Loop-Enabled
- Engine Shut Down

Circuit Description

The TMAP is a combined IAT (Intake Air Temperature) and MAP (Manifold Absolute Pressure) sensor. A temperature sensitive resistor is used in the TMAP located in the intake manifold of the engine. It is used to monitor incoming air temperature, and the output in conjunction with other sensors is used to determine the airflow to the engine. The ECM provides a voltage divider circuit so that when the air is cool, the signal reads higher voltage, and lower when warm.

The IAT is a calculated value based mainly on the IAT sensor at high airflow, and influenced more by the ECT (Engine Coolant Temperature) at low airflow.

This fault will set if the Intake Air Temperature is greater than 220 degrees F and engine RPM is greater than 1000. The MIL light will be on during this active fault and the engine will shut down.

DTC 114-IAT Higher Than Expected 2 (Bosch TMAP)

Diagnostic Aids

- * This fault will set when inlet air is much hotter than normal. The most common cause of high inlet air temperature is a problem with the inlet air system. Ensure that the air inlet is not obstructed, modified or damaged.
- * Inspect the air inlet system for cracks or breaks that may allow unwanted under hood air in to the air inlet system
- * If none of the above can be found, Follow the diagnostic steps for DTC 112-IAT Low Voltage.

DTC 115-Oil Pressure Low

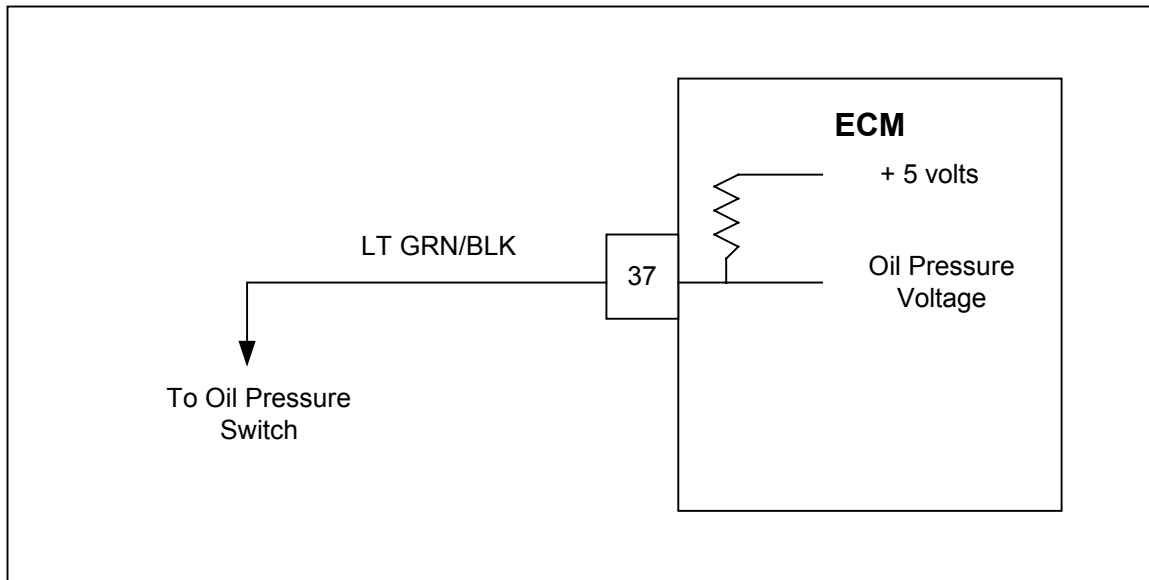

Conditions for Setting the DTC

- Engine Oil Pressure low
- Check Condition-Engine running for 35 seconds and RPM greater than 600
- Fault Condition- Closed circuit/voltage low
- MIL-On during active fault and for 3 seconds after active fault
- Adaptive-Enabled
- Closed Loop-Enabled
- Engine Shut Down

Circuit Description

The Oil Pressure Switch is used to communicate a low oil pressure condition to the ECM. Engine damage can occur if the engine is operated with low oil pressure. The ECM uses an analog voltage input with an internal 5 volt reference. If the oil pressure circuit is grounded, the input voltage will be near zero. If it is open, the input will be near 5 volts. The switch is normally closed and the fault will set if the circuit becomes open. The engine will shut down in the event of this fault to help prevent possible damage.

DTC 115- Oil Pressure Low

Step	Action	Value(s)	Yes	No
1	Did you perform the On-Board (OBD) System Check?	-	Go to Step (2)	Go to OBD System Check Section
2	<ul style="list-style-type: none"> Verify that the engine has oil pressure using a mechanical oil pressure gauge before proceeding with this chart. <p>Does the engine have oil pressure?</p>	25-45 psi	Go to Step (3)	Repair faulty Oiling System
3	<ul style="list-style-type: none"> Key On, Engine Running DST connected in System Data Mode Clear DTC 115 Warm the engine by idling until the ECT temperature is above 160 degrees F. and has been running for at least one minute <p>Does DTC115 reset and cause the engine to shut down?</p>		Go to Step (4)	Intermittent problem Go to Intermittent section
4	<ul style="list-style-type: none"> Key OFF Disconnect oil pressure switch harness connector C005 Disconnect ECM header connector Check circuit resistance between oil pressure switch connector and ECM harness pin 37. It should be less than 5 ohms Check oil pressure switch circuit for short to ground <p>Was problem found?</p>		Repair circuit wiring	Go to Step (5)
5	<ul style="list-style-type: none"> Replace the oil pressure switch <p>Is problem fixed?</p>		Go to Step (8)	Go to Step (6)

6	<ul style="list-style-type: none"> Inspect ECM connector pin 37 for damage corrosion or contamination <p>Did you find a problem?</p>		<p>Repair the circuit as necessary. Refer to Wiring Repairs in Engine Electrical.</p>	<p>Go to Step (7)</p>
7	<ul style="list-style-type: none"> Replace ECM Is the replacement complete? 		<p>Go to Step (8)</p>	<p>-</p>
8	<ul style="list-style-type: none"> Remove all test equipment except the DST. Connect any disconnected components, fuses, etc. Using the DST clear DTC information from the ECM. Turn the ignition OFF and wait 30 seconds. Start the engine and operate the vehicle to full operating temperature Observe the MIL Observe engine performance and driveability After operating the engine within the test parameters of DTC-115 check for any stored codes. <p>Does the engine operate normally with no stored codes?</p>		<p>System OK</p>	<p>Go to OBD System Check</p>

DTC 121-ECT / High Voltage

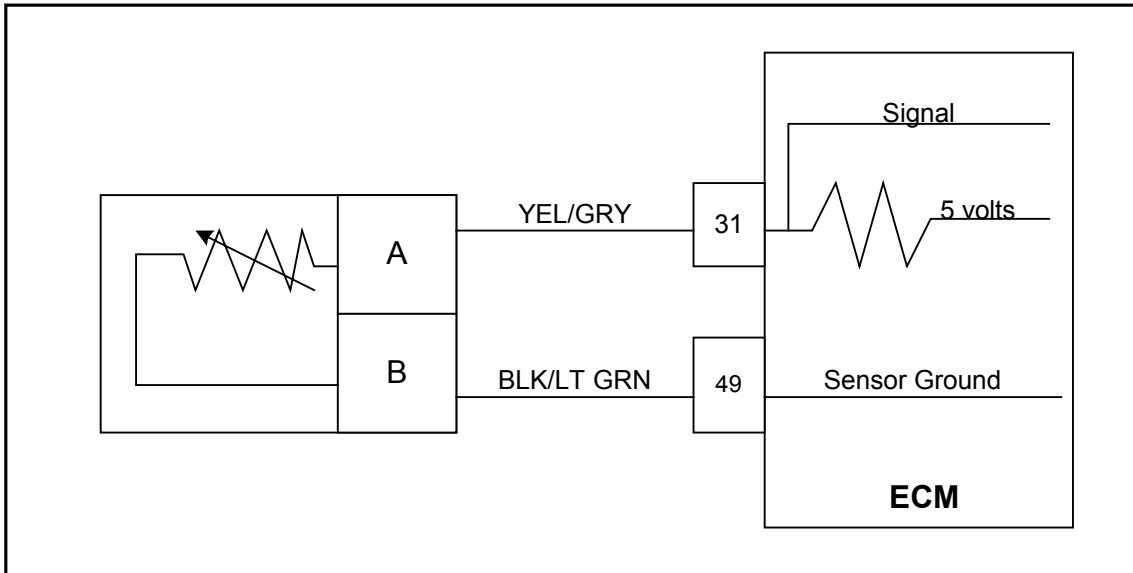

Conditions for Setting the DTC

- Engine Coolant Temperature
- Check Condition-Engine Running
- Fault Condition-ECT sensor voltage exceeds 4.95
- MIL-On during active fault and for 2 seconds after active fault
- Adaptive-Disabled during active fault
- Closed Loop-Enabled

Circuit Description

The ECT (Engine Coolant Temperature) sensor is a temperature sensitive resistor located in the engine coolant. It is used for the engine airflow calculation, gasoline cold enrichment and to enable other temperature dependant features. The ECM provides a voltage divider circuit so that when the coolant is cool, the signal reads higher voltage, and lower when warm. This fault will set if the signal voltage is greater than 4.95 volts anytime the engine is running. The ECM will use a default value for the ECT sensor in the event of this fault.

TEMPERATURE VS. RESISTANCE CHART

IAT Data:			ECT Data:		
Temp (deg F)	Ohms		Temp (deg F)	Ohms	
248.0	110		242.4	101	
239.0	125		231.9	121	
221.0	162		211.6	175	
203.0	214		201.4	209	
185.0	284		181.9	302	
167.0	383		163.1	434	
149.0	522		144.9	625	
131.0	721		127.4	901	
104.0	1,200		102.4	1,556	
77.0	2,063		78.9	2,689	
50.0	3,791		49.9	5,576	
23.0	7,419		23.5	11,562	
-4.0	15,614		-5.7	28,770	
-22.0	26,854		-21.2	49,715	
-31.0	35,763		-30.8	71,589	
-40.0	48,153		-40.0	99,301	

DTC 121- ECT VOLTAGE HIGH

Step	Action	Value(s)	Yes	No
1	Did you perform the On-Board (OBD) System Check?	-	Go to Step (2)	Go to OBD System Check Section
2	<ul style="list-style-type: none"> • Key On • DST (Diagnostic Scan Tool) connected in System Data Mode Does DST display ECT voltage of 4.95 or greater?		Go to step (3)	Intermittent problem Go to Intermittent section
3	<ul style="list-style-type: none"> • Key Off • Disconnect the ECT sensor from the wiring harness and Jumper connector terminals A and B together • Key On Does the DST display ECT voltage of 0.05 volts or less?		Go to step (4)	Go to Step (8)
4	<ul style="list-style-type: none"> • Using a DVOM check the resistance between the two terminals of the ECT sensor and compare the resistance reading to the chart Is the resistance value correct?	See resistance chart vs. temperature in the DTC 121 circuit description	Go to Step (6)	Go to step (5)
5	<ul style="list-style-type: none"> • Replace ECT sensor Is the replacement complete?		Go to Step (14)	-
6	<ul style="list-style-type: none"> • Inspect the ECT wire harness connector terminals for damage, corrosion or contamination Did you find a problem?		Repair the circuit as necessary. Refer to Wiring Repairs in Engine Electrical.	Go to Step (7)
7	<ul style="list-style-type: none"> • Key OFF • Disconnect ECM wire harness connector • Inspect ECM connector pins 31 and 49 for damage corrosion or contamination • Did you find a problem? 		Repair the circuit as necessary. Refer to Wiring Repairs in Engine Electrical.	Intermittent problem Go to Intermittent section
8	<ul style="list-style-type: none"> • Jumper the ECT signal pin A at the ECT connector to engine ground Does DST display ECT voltage of 0.05 or less?		Go to Step (9)	Go to Step (12)

9	<ul style="list-style-type: none"> • Key OFF • Disconnect ECM wire harness connector • Using a DVOM check for continuity between ECT sensor ground pin B and ECM connector pin 49 <p>Do you have continuity between them?</p>		Go to Step (10)	Repair the circuit as necessary. Refer to Wiring Repairs in Engine Electrical.
10	<ul style="list-style-type: none"> • Inspect ECM connector pins 31 and 49 for damage, corrosion or contamination <p>Did you find a problem?</p>		Repair the circuit as necessary. Refer to Wiring Repairs in Engine Electrical.	Go to Step (11)
11	<ul style="list-style-type: none"> • Replace ECM <p>Is the replacement complete?</p>		Go to Step (14)	-
12	<ul style="list-style-type: none"> • Key OFF • Disconnect ECM wire harness connector • Using A DVOM check for continuity between ECT connector signal pin A and ECM connector terminal 31 <p>Do you have continuity between them?</p>		Go to Step (13)	Repair the circuit as necessary. Refer to Wiring Repairs in Engine Electrical.
13	<ul style="list-style-type: none"> • Inspect ECM connector pins 31 and 49 for damage, corrosion or contamination <p>Did you find a problem?</p>		Repair the circuit as necessary. Refer to Wiring Repairs in Engine Electrical.	Go to Step (11)
14	<ul style="list-style-type: none"> • Remove all test equipment except the DST. • Connect any disconnected components, fuses, etc. • Using the DST clear DTC information from the ECM. • Turn the ignition OFF and wait 30 seconds. • Start the engine and operate the vehicle to full operating temperature • Observe the MIL • Observe engine performance and driveability • After operating the engine within the test parameters of DTC-121 check for any stored codes. <p>Does the engine operate normally with no stored codes?</p>		System OK	Go to OBD System Check

DTC 122-ECT Low Voltage

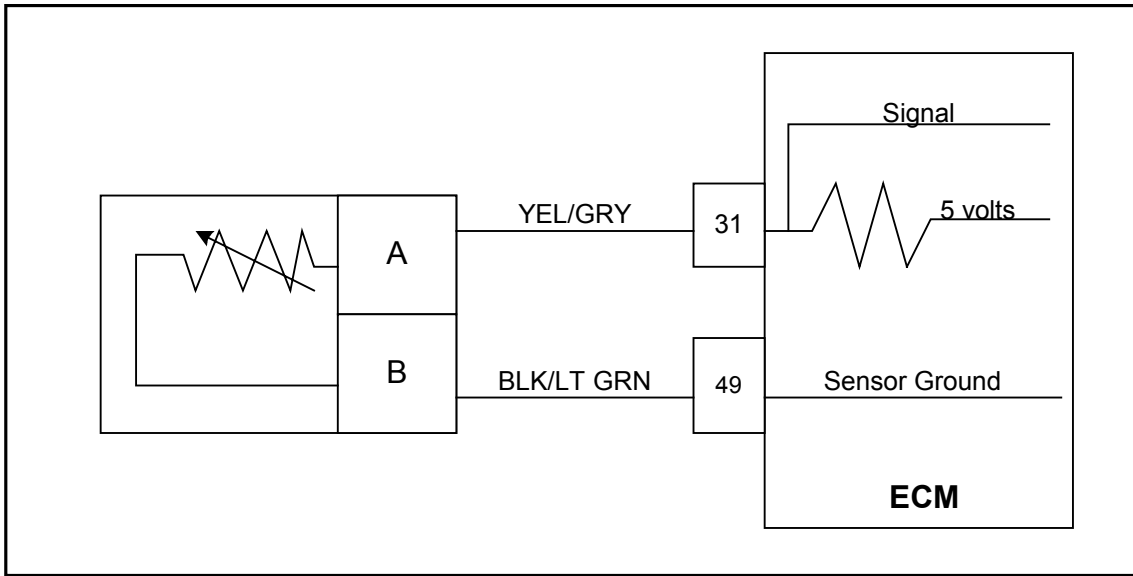

Conditions for Setting the DTC

- Engine Coolant Temperature
- Check Condition-Engine Running
- Fault Condition- ECT sensor voltage less than 0.05
- MIL-On during active fault and for 2 seconds after active fault
- Adaptive-Disabled during active fault
- Closed Loop-Enabled

Circuit Description

The ECT (Engine Coolant Temperature) sensor is a temperature sensitive resistor located in the engine coolant. It is used for the engine airflow calculation, gasoline cold enrichment and to enable other temperature dependant features. The ECM provides a voltage divider circuit so that when the coolant is cool, the signal reads higher voltage, and lower when warm

This fault will set if the signal voltage is less than 0.05 volts anytime the engine is running. The ECM will use a default value for the ECT sensor in the event of this fault.

DTC 122- ECT VOLTAGE LOW

Step	Action	Value(s)	Yes	No
1	Did you perform the On-Board (OBD) System Check?	—	Go to Step (2)	Go to OBD System Check Section
2	<ul style="list-style-type: none"> • Key On • DST (Diagnostic Scan Tool) connected in • System Data Mode Does DST display ECT voltage of 0.05 or less?		Go to step (3)	Intermittent problem Go to Intermittent section
3	<ul style="list-style-type: none"> • Key Off • Disconnect the ECT wire harness connector • Key ON Does the DST display ECT voltage of 4.9 volts or greater?		Go to step (4)	Go to step (6)
4	<ul style="list-style-type: none"> • Using a DVOM check the resistance between the two terminals of the ECT sensor and compare the resistance reading to the chart Is the resistance value correct?	See resistance chart vs. temperature in the DTC 121 circuit description	Go to Step (6)	Go to step (5)
5	Replace ECT sensor. Is the replacement complete?		Go to Step (9)	—
6	<ul style="list-style-type: none"> • Key OFF • Disconnect ECM wire harness connector • Check for continuity between ECT sensor connector signal pin A and ECT sensor ground pin B Do you have continuity between them?	—	Repair the circuit as necessary. Refer to Wiring Repairs in Engine Electrical.	Go to step (7)

7	<ul style="list-style-type: none"> • Check for continuity between ECT sensor connector signal circuit pin A and engine ground. <p>Do you have continuity?</p>	—	<p>Repair the circuit as necessary. Refer to Wiring Repairs in Engine Electrical.</p>	Go to step (8)
8	<p>Replace ECM. Refer to ECM replacement in the Engine Controls Section.</p> <p>Is the replacement complete?</p>	—	Go to step (9)	—
9	<ul style="list-style-type: none"> • Remove all test equipment except the DST. • Connect any disconnected components, fuses, etc. • Using the DST clear DTC information from the ECM. • Turn the ignition OFF and wait 30 seconds. • Start the engine and operate the vehicle to full operating temperature • Observe the MIL • Observe engine performance and driveability • After operating the engine within the test parameters of DTC-122 check for any stored codes. <p>Does the engine operate normally with no stored codes?</p>		System OK	Go to OBD System Check

DTC 123-ECT Higher Than Expected 1

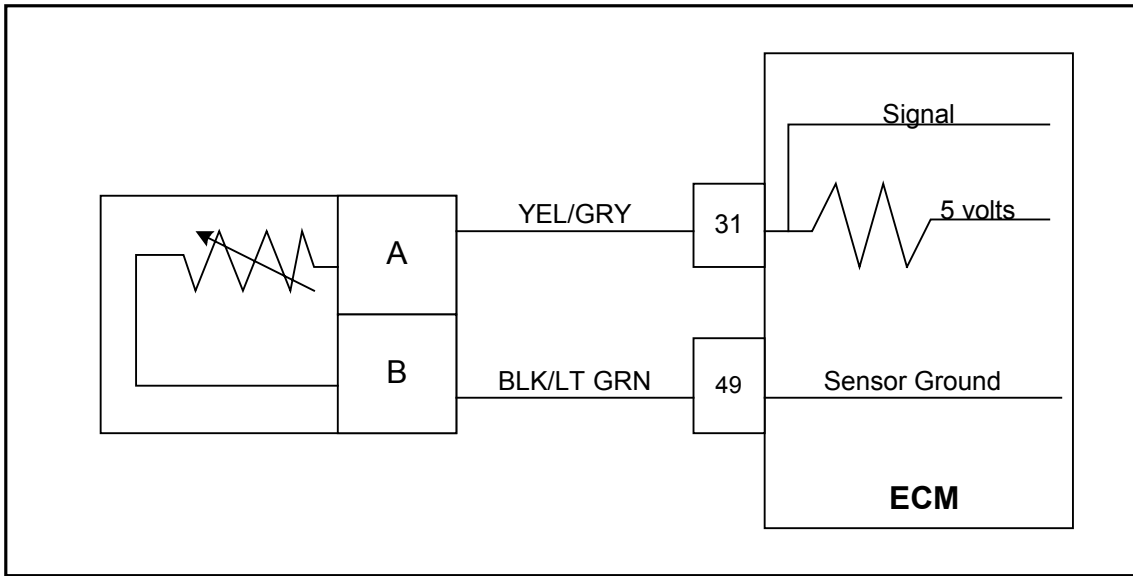

Conditions for Setting the DTC

- Engine Coolant Temperature
- Check Condition-Engine Running
- Fault Condition-Engine Coolant Temperature reading or estimate greater than 225 deg. F and engine RPM greater than 1200
- MIL-Will flash at 2 Hz (twice per second) during active fault
- Adaptive-Disabled during active fault
- Closed Loop-Enabled and allowed to stay at limit (will still set limit fault)
- Power Derate (level1)

Circuit Description

The Engine Coolant Temperature sensor is a thermistor (temperature sensitive resistor) located in the engine coolant. The ECT (Engine Coolant Temperature) sensor that is located in the coolant near the thermostat. The ECT is used for engine airflow calculation, fuel enrichment, ignition timing control, to enable certain features, and for engine protection. The ECM provides a voltage divider circuit so when the sensor reading is cool the sensor reads higher voltage, and lower when warm.

This fault will help protect the engine in the event of over temperature. When the coolant exceeds 225 degrees F. and engine RPM exceeds 1200 this fault will set and Power Derate 1 will be enforced. During this fault, maximum throttle position is 50% and the MIL light will flash twice per second.

DTC 123- ECT HIGHER THAN EXPECTED 1

Step	Action	Value(s)	Yes	No
1	Did you perform the On-Board (OBD) System Check?	-	Go to Step (2)	Go to OBD System Check Section
2	<ul style="list-style-type: none"> • Key On • DST (Diagnostic Scan Tool) connected in System Data Mode • Warm Engine to normal operating temperature, then run the engine for 60 seconds Does DST display ECT temperature of 230 degrees F. or greater with the engine running?		Go to Step (3)	Intermittent problem Go to Intermittent section
3	<ul style="list-style-type: none"> • Verify with a temperature gauge that the engine coolant is over 225 degrees F. Does the temperature gauge indicate 225 degrees F. or greater? 		Repair Cooling system.	Go to step (4)
4	Verify ECT circuit function. Follow diagnostic test procedure for DTC-122 ECT Low Voltage		-	-

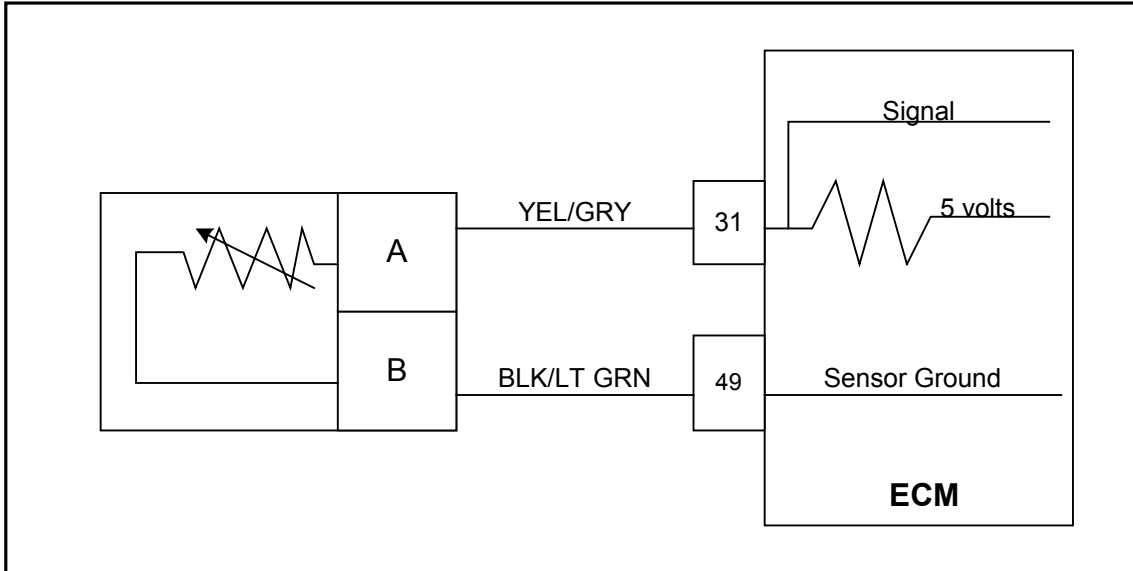
DTC 124-ECT Higher Than Expected 2**Conditions for Setting the DTC**

- Engine Coolant Temperature
- Check Condition-Engine Running
- Fault Condition-Engine Coolant temperature reading or estimate greater than 250 deg. F and engine RPM greater than 650
- MIL-On for active fault and for 15 seconds after active fault
- Adaptive-Enabled
- Closed Loop-Enabled and allowed to stay at limit (will still set limit fault)
- Engine Shut Down

Circuit Description

The Engine Coolant Temperature sensor is a thermistor (temperature sensitive resistor) located in the engine coolant. The ECT (Engine Coolant Temperature) sensor that is located in the coolant near the thermostat. The ECT is used for engine airflow calculation, ignition timing control, fuel enrichment, to enable certain features, and for engine protection. The ECM provides a voltage divider circuit so when the sensor reading is cool, the signal reads higher voltage, and lower when warm. This fault will set if coolant temperature reaches 250 degrees F. and engine RPM exceeds 650 rpm the engine will shut down.

DTC 124 ECT Higher than expected 2

Step	Action	Value(s)	Yes	No
1	Did you perform the On-Board (OBD) System Check?	-	<i>Go to Step (2)</i>	<i>Go to OBD System Check Section</i>
2	<ul style="list-style-type: none"> • Key On • DST (Diagnostic Scan Tool) connected in System Data Mode • Warm Engine to normal operating temperature, then run the engine above 1000 rpm for 60 seconds • Does DST display ECT temperature of 235 degrees F. or greater with the engine running over 650 rpm? 		<i>Go to Step (3)</i>	<i>Intermittent problem Go to Intermittent section</i>
3	<ul style="list-style-type: none"> • Verify with a temperature gauge that the engine coolant is over 225 degrees F. Does the temperature gauge indicate 230 degrees F. or greater?		<i>Repair Cooling system.</i>	<i>Go to step (4)</i>
4	Verify ECT circuit function. Follow diagnostic test procedure for DTC-122 ECT Low Voltage		-	-

DTC 131-MAP High Pressure Bosch TMAP

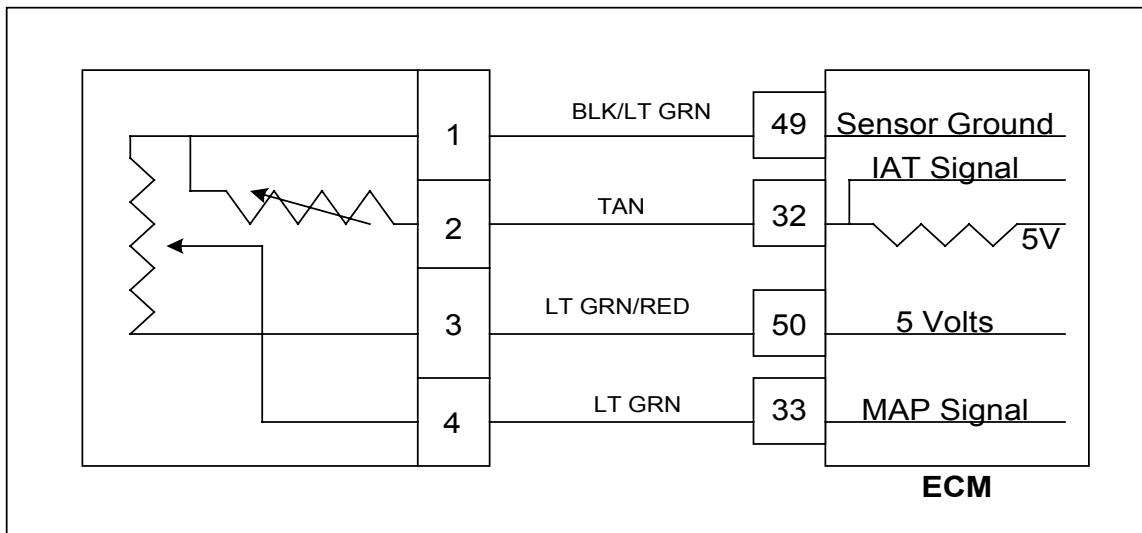

Conditions for Setting the DTC

- Manifold Absolute Pressure
- Check Condition-RPM greater than 800, Throttle Command less than 10%, steady MAP and TPS
- Fault Condition-MAP greater than 18 psia, TPS less than 10% and engine RPM greater than 1800.
- MIL-On for remainder of key on cycle
- Adaptive-Disabled for remainder of key on cycle
- Closed Loop-Enabled and allowed to stay at limit
- Misc.-Fueling is based on RPM and TPS Limp-Home Condition during this fault.

Circuit Description

The TMAP is a combined inlet manifold temperature and pressure sensor connected to the intake manifold. It is used to measure the pressure of air in the manifold prior to induction into the engine. The pressure reading is used in conjunction with other inputs to determine the airflow rate to the engine, which also determines the fuel flow rate. This fault will set when the MAP reading is higher than it should be for the given TPS, and RPM. When the fault is set, the Adaptive Learn will be disabled for the remainder of the key on cycle and the MIL will be on. The engine will operate on a default MAP during this active fault.

Diagnostic Aids

If the engine is running rough, unstable or missing due to a suspected mechanical problem, vacuum leak or other issue causing misfire these problems must be taken care before using the MAP diagnostic chart. Failure to follow this recommendation will result in a false MAP diagnostic and repair procedure.

DTC 131- MAP HIGH PRESSURE (Bosch TMAP)

Step	Action	Value(s)	Yes	No
1	Did you perform the On-Board (OBD) System Check?	-	Go to Step (2)	Go to OBD System Check Section
2	<ul style="list-style-type: none"> • Key On, Engine running. • DST (Diagnostic Scan Tool) connected in System Data Mode Does DST display MAP pressure of 13.0 psia or greater with the engine idling?		Go to step (3)	Intermittent problem Go to Intermittent section
3	<ul style="list-style-type: none"> • Key OFF • Disconnect the TMAP sensor connector • Key ON Does the DST display MAP pressure less than 0.05 psia?		Go to step (4)	Go to step (6)
4	<ul style="list-style-type: none"> • Probe TMAP sensor connector ground circuit pin 1 with a test light connected to battery voltage. Does the test light come on?		Go to step (5)	Go to step (8)
5	<ul style="list-style-type: none"> • Check TMAP mechanical connection for correct mounting or possible damage causing leakage. Is the TMAP sensor mechanical connection OK?		Go to step (6)	Go to Step (10)
6	<ul style="list-style-type: none"> • Key OFF • Disconnect ECM connector and inspect terminals for damage corrosion or contamination. Is the connection OK? 		Go to step (7)	Repair the circuit as necessary. Refer to Wiring Repairs in Engine Electrical.
7	Replace TMAP sensor. Is the repair complete?	—	Go to step (11)	-
8	<ul style="list-style-type: none"> • Disconnect ECM connector and check for continuity between TMAP connector sensor ground pin 1 and ECM sensor ground PIN 49. Do you have continuity between them?		Go to step (9)	Repair the circuit as necessary. Refer to Wiring Repairs in Engine Electrical.

9	<p>Replace ECM. Refer to ECM replacement in the Engine Controls Section.</p> <p>Is the replacement complete?</p>		Go to step (11)	-
10	<ul style="list-style-type: none"> • Correct TMAP mechanical connection <p>Has TMAP mechanical connection been corrected?</p>		Go to Step (11)	-
11	<ul style="list-style-type: none"> • Remove all test equipment except the DST. • Connect any disconnected components, fuses, etc. • Using the DST clear DTC information from the ECM. • Turn the ignition OFF and wait 30 seconds. • Start the engine and operate the vehicle to full operating temperature <ul style="list-style-type: none"> • Observe the MIL • Observe engine performance and driveability • After operating the engine within the test parameters of DTC-131 check for any stored codes. <p>Does the engine operate normally with no stored codes?</p>		System OK	Go to OBD System Check

DTC 132-MAP Low Voltage (Bosch TMAP)

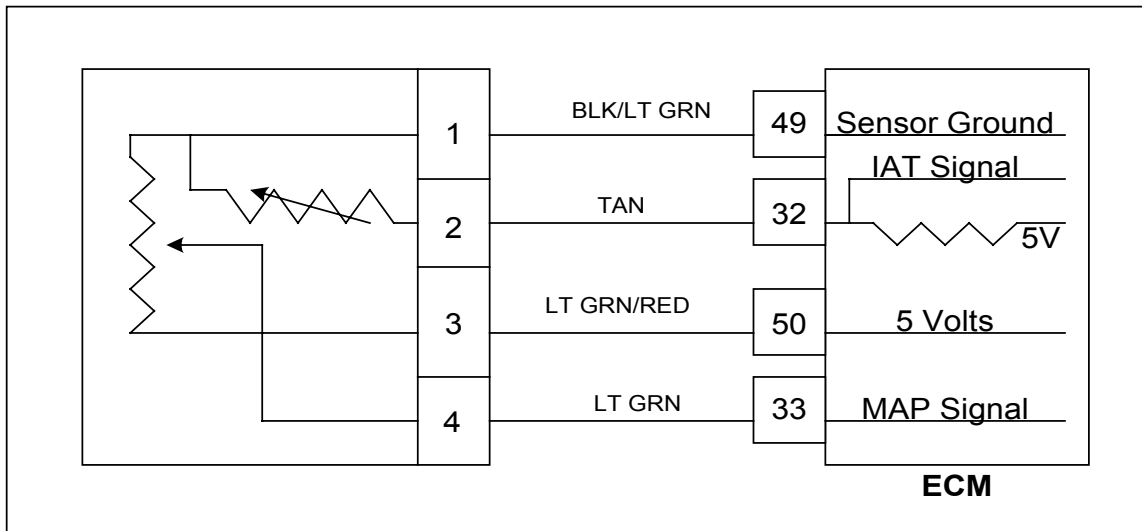

Conditions for Setting the DTC

- Manifold Absolute Pressure
- Check Condition-Cranking or Running
- Fault Condition-MAP voltage less than 0.05, Throttle Position greater than 2% and engine RPM less than 7000.
- MIL-On for remainder of key on cycle
- Adaptive-Disabled for remainder of key on cycle
- Closed Loop-Enabled
- Misc.-Fueling is based on RPM and TPS Limp-Home Condition during this fault.

Circuit Description

The Manifold Absolute Pressure sensor is a pressure transducer connected to the intake manifold. It is used to measure the pressure of air in the manifold prior to induction into the engine. The pressure reading is used in conjunction with other inputs to determine the airflow rate to the engine, which determines the fuel flow rate. This fault will set when the MAP reading is lower than the sensor should normally produce. When this fault is set the Adaptive Learn will be disabled for the remainder of the key on cycle and the MIL will be on.

DTC 132- MAP Low Voltage (Bosch TMAP)

Step	Action	Value(s)	Yes	No
1	Did you perform the On-Board (OBD) System Check?	-	Go to Step (2)	Go to OBD System Check Section
2	<ul style="list-style-type: none"> Key On, Engine running. DSC (Diagnostic Scan Tool) connected in System Data Mode Does DST display MAP voltage of 0.05 or less with the engine idling?		Go to Step (3)	Intermittent problem Go to Intermittent section
3	<ul style="list-style-type: none"> Key OFF Disconnect the TMAP sensor from the wiring harness Jumper the 5 volt reference pin 3 and MAP signal circuit pin 4 together Key ON Does the DST display MAP voltage of 4.5 volts or greater?		Go to Step (4)	Go to step (8)
4	<ul style="list-style-type: none"> Inspect TMAP connector and pins for corrosion, contamination or mechanical damage Any problems found?		Repair the circuit as necessary. Refer to Wiring Repairs in Engine Electrical.	Go to step (5)
5	<ul style="list-style-type: none"> Key OFF Disconnect ECM connector Check for continuity between TMAP sensor connector signal pin 4 and ECM MAP signal pin 33. Do you have continuity between them?		Go to Step (6)	Repair the circuit as necessary. Refer to Wiring Repairs in Engine Electrical.
6	<ul style="list-style-type: none"> Check for continuity between TMAP sensor connector 5 volt supply signal pin 3 and ECM 5 volt supply pin 50 Do you have continuity between them?		Go to step (7)	Repair the circuit as necessary. Refer to Wiring Repairs in Engine Electrical.

7	<ul style="list-style-type: none"> Check for continuity between TMAP sensor connector ground pin 1 and ECM sensor ground pin 49 <p>Do you have continuity between them?</p>		Go to step (17)	Repair the circuit as necessary. Refer to Wiring Repairs in Engine Electrical.
8	<ul style="list-style-type: none"> Probe MAP connector signal circuit pin 4 with a test light connected to battery voltage <p>Does the DST display MAP voltage of 4.0 or greater?</p>		Go to Step (9)	Go to step (13)
9	<ul style="list-style-type: none"> Key OFF Disconnect ECM connector Check for continuity between TMAP sensor connector pin 3 and ECM 5 volt reference pin 50. <p>Do you have continuity between them?</p>		Go to step (10)	Repair the circuit as necessary. Refer to Wiring Repairs in Engine Electrical.
10	<ul style="list-style-type: none"> Check for continuity between TMAP sensor connector 5 volt reference pin 3 and engine ground <p>Do you have continuity?</p>		Repair the circuit as necessary. Refer to Wiring Repairs in Engine Electrical.	Go to Step (11)
11	<ul style="list-style-type: none"> Inspect ECM and TMAP wire harness connector and terminals for corrosion, contamination or mechanical damage <p>Any problems found?</p>		Repair the circuit as necessary. Refer to Wiring Repairs in Engine Electrical.	Go to Step (16)
12	<p>Replace ECM. Refer to ECM replacement in the Engine Controls Section.</p> <p>Is the replacement complete?</p>		Go to step (17)	-
13	<ul style="list-style-type: none"> Disconnect ECM connector Check for continuity between TMAP sensor connector signal circuit pin 4 and ECM signal PIN 33 <p>Do you have continuity between them?</p>		Go to Step (14)	Repair the circuit as necessary. Refer to Wiring Repairs in Engine Electrical.

14	<ul style="list-style-type: none"> • Check for continuity between TMAP sensor connector signal pin 4 and engine ground Do you have continuity? 		Repair the circuit as necessary. Refer to Wiring Repairs in Engine Electrical.	Go to step (15)
15	<ul style="list-style-type: none"> • Inspect ECM connector and wire harness connector terminals for corrosion, contamination or mechanical damage Any problems found? 		Repair the circuit as necessary. Refer to Wiring Repairs in Engine Electrical.	Go to Step (16)
16	Replace ECM. Refer to ECM replacement in the Engine Controls Section. Is the replacement complete?		Go to Step (18)	-
17	Replace TMAP sensor Is the replacement complete?		Go to step (17)	-
18	<ul style="list-style-type: none"> • Remove all test equipment except the DSC. • Connect any disconnected components, fuses, etc. • Using the DST clear DTC information from the ECM. • Turn the ignition OFF and wait 30 seconds. • Start the engine and operate the vehicle to full operating temperature • Observe the MIL • Observe engine performance and driveability • After operating the engine within the test parameters of DTC-132 check for any stored codes. <p>Does the engine operate normally with no stored codes?</p>		System OK	Go to OBD System Check

DTC 134-BP High Pressure (Bosch TMAP)

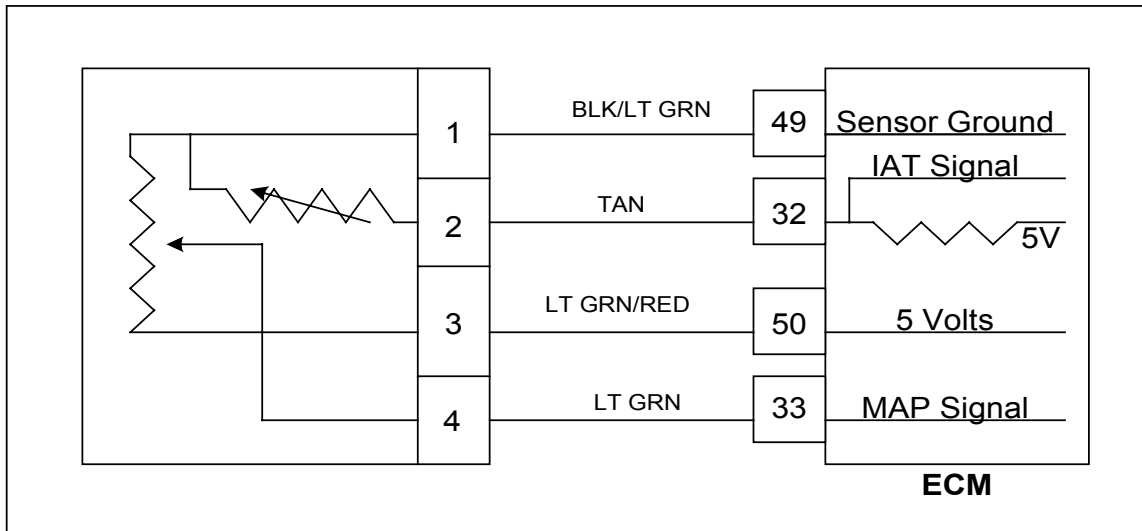

Conditions for Setting the DTC

- Barometric Pressure
- Check Condition-Key On
- Fault Condition-BP greater than 16 psia
- MIL-On for active fault and for 2 seconds after active fault
- Adaptive-Disabled for remainder of key on cycle
- Closed Loop-Enabled

Circuit Description

The BP (Barometric Pressure) is estimated from the TMAP sensor. The barometric pressure value is used for fuel and airflow calculations. This fault sets in the event the BP value is out of the normal range.

DTC 134- BP High Pressure (Bosch TMAP)

	Action	Value(s)	Yes	No
1	Did you perform the On-Board (OBD) System Check?	-	Go to Step (2)	Go to OBD System Check Section
2	<ul style="list-style-type: none"> • Key On • DST (Diagnostic Scan Tool) connected in • System Data Mode <p>Does DST display MAP pressure of 16 psia or greater?</p>		Go to step (3)	Intermittent problem Go to Intermittent section
3	Replace TMAP sensor. Is the repair complete?		Go to Step (3)	-
	<ul style="list-style-type: none"> • Remove all test equipment except the DST. • Connect any disconnected components, fuses, etc. • Using the DST clear DTC information from the ECM. • Turn the ignition OFF and wait 30 seconds. • Start the engine and operate the vehicle to full operating temperature <ul style="list-style-type: none"> • Observe the MIL • Observe engine performance and driveability • After operating the engine within the test parameters of DTC-134 check for any stored codes. <p>Does the engine operate normally with no stored codes?</p>		System Ok	Go to OBD System Check

DTC 135-BP Low Pressure (Bosch TMAP)

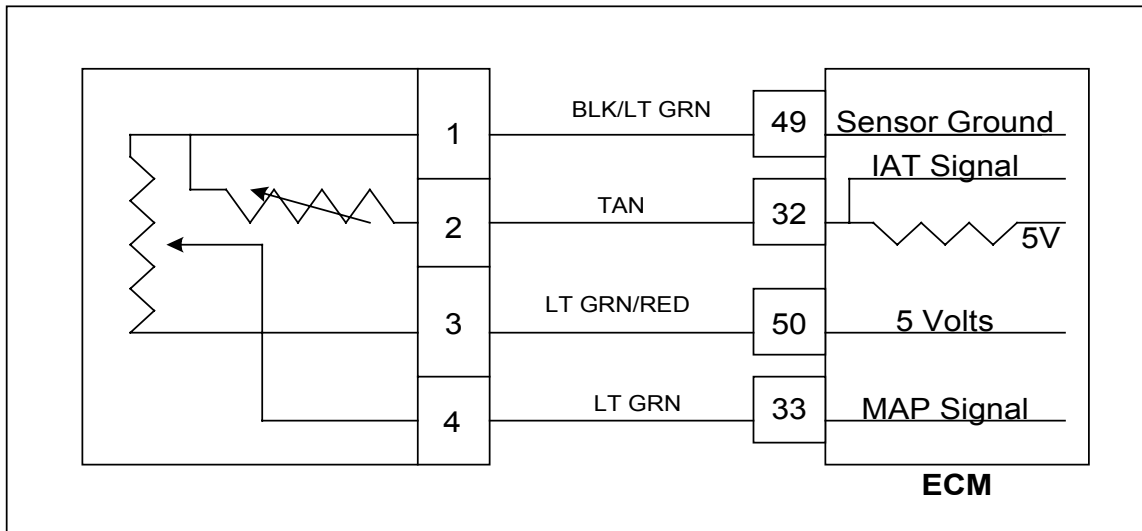

Conditions for Setting the DTC

- Barometric Pressure
- Check Condition-Key On
- Fault Condition-BP less than 8.3 psia
- MIL-On for active fault and for 2 seconds after active fault
- Adaptive-Disabled for remainder of key on cycle
- Closed Loop-Enabled

Circuit Description

The BP (Barometric Pressure) is estimated from the TMAP sensor. The barometric pressure value is used for fuel and airflow calculations. This fault sets in the event the BP value is out of the normal range.

DTC 135- BP Low Pressure (Bosch TMAP)

Step	Action	Value(s)	Yes	No
1	Did you perform the On-Board (OBD) System Check?	-	Go to Step (2)	Go to OBD System Check Section
2	<ul style="list-style-type: none"> • Key On. • DST (Diagnostic Scan Tool) connected in System Data Mode Does DST display BP pressure of 8.3 psia or less?		Go to Step (3)	Intermittent problem Go to Intermittent section
3	<ul style="list-style-type: none"> • Key OFF • Disconnect the TMAP sensor from the wiring harness • Jumper the 5 volt reference pin 3 and MAP signal pin 4 together • Key ON Does the DST display BP pressure of 16.00 psia or greater?		Go to Step (4)	Go to step (8)
4	<ul style="list-style-type: none"> • Inspect TMAP connector and wire harness connector terminals for corrosion, contamination or mechanical damage Any problems found?		Repair the circuit as necessary. Refer to Wiring Repairs in Engine Electrical.	Go to step (5)
5	<ul style="list-style-type: none"> • Key OFF • Disconnect ECM connector • Check for continuity between TMAP sensor connector pin 4 and ECM connector pin 33 Do you have continuity between them?		Go to Step (6)	Repair the circuit as necessary. Refer to Wiring Repairs in Engine Electrical.
6	<ul style="list-style-type: none"> • Check for continuity between TMAP sensor connector 5 volt supply pin 3 and ECM connector pin 50 Do you have continuity between them?		Go to step (7)	Repair the circuit as necessary. Refer to Wiring Repairs in Engine Electrical.

7	<ul style="list-style-type: none"> Check for continuity between TMAP sensor connector ground pin 1 and ECM connector pin 49 <p>Do you have continuity between them?</p>		Go to step (17)	Repair the circuit as necessary. Refer to Wiring Repairs in Engine Electrical.
8	<ul style="list-style-type: none"> Remove Jumper that was installed during step 3 Probe TMAP connector signal circuit pin 4 with a test light connected to battery voltage <p>Does the DST display BP pressure of 16.00 psia or greater?</p>		Go to Step (9)	Go to step (13)
9	<ul style="list-style-type: none"> Key OFF Disconnect ECM connector Check for continuity between TMAP sensor connector pin 3 and ECM connector pin 50 <p>Do you have continuity between them?</p>		Go to step (10)	Repair the circuit as necessary. Refer to Wiring Repairs in Engine Electrical.
10	<ul style="list-style-type: none"> Check for continuity between TMAP sensor connector 5 volt reference pin 3 and engine ground <p>Do you have continuity?</p>		Repair the circuit as necessary. Refer to Wiring Repairs in Engine Electrical.	Go to Step (11)
11	<ul style="list-style-type: none"> Inspect TMAP and ECM connector pins for corrosion, contamination or mechanical damage <p>Any problems found?</p>		Repair the circuit as necessary. Refer to Wiring Repairs in Engine Electrical.	Go to Step (16)
12	<p>Replace ECM. Refer to ECM replacement in the Engine Controls Section.</p> <p>Is the replacement complete?</p>		Go to step(17)	-
13	<ul style="list-style-type: none"> Disconnect ECM connector C001 Check for continuity between TMAP sensor connector pin 4 and ECM pin 33 <p>Do you have continuity between them?</p>		Go to Step (14)	Repair the circuit as necessary. Refer to Wiring Repairs in Engine Electrical.

14	<ul style="list-style-type: none"> Check for continuity between TMAP sensor connector pin 4 and engine ground Do you have continuity? 		Repair the circuit as necessary. Refer to Wiring Repairs in Engine Electrical.	Go to step (15)
15	<ul style="list-style-type: none"> Inspect ECM connector and wire harness connector pins for corrosion, contamination or mechanical damage Any problems found? 		Repair the circuit as necessary. Refer to Wiring Repairs in Engine Electrical.	Go to Step (16)
16	Replace ECM. Refer to ECM replacement in the Engine Controls Section. Is the replacement complete?		Go to Step (18)	-
17	Replace TMAP sensor Is the replacement complete?		Go to step (17)	-
18	<ul style="list-style-type: none"> Remove all test equipment except the DST. Connect any disconnected components, fuses, etc. Using the DST clear DTC information from the ECM. Turn the ignition OFF and wait 30 seconds. Start the engine and operate the vehicle to full operating temperature Observe the MIL Observe engine performance and driveability After operating the engine within the test parameters of DTC-135 check for any stored codes. <p>Does the engine operate normally with no stored codes?</p>		System OK	Go to OBD System Check

DTC 142-Crank Sync Noise

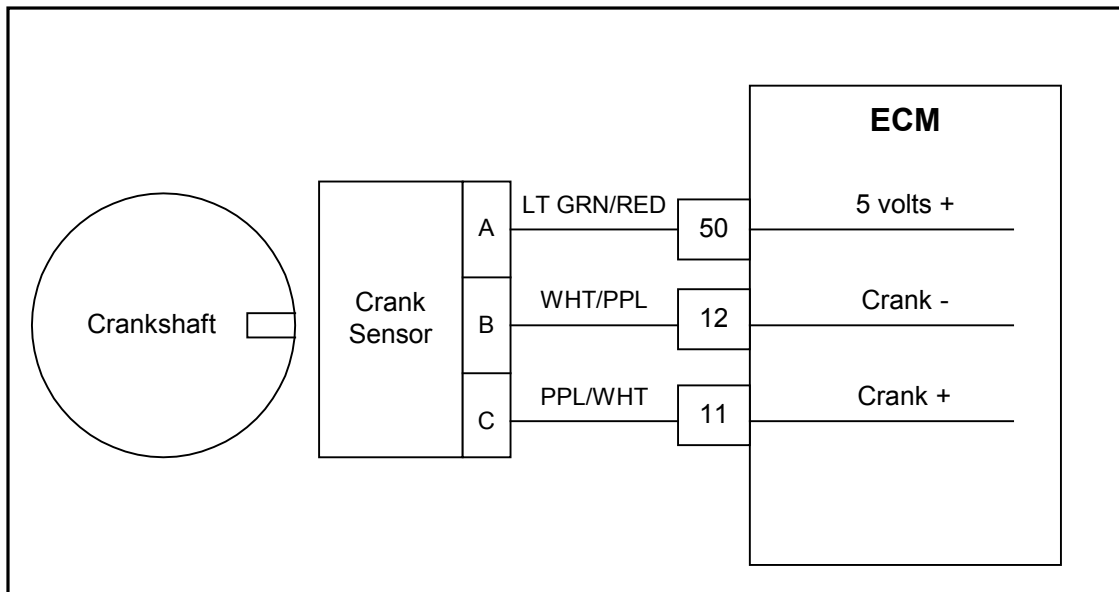

Conditions for setting the DTC

- Crankshaft Position sensor
- Check Condition- Engine running
- Fault Condition- 1 invalid crank re-sync
- MIL- On during active fault and for 10 seconds after active fault
- Adaptive- Disabled for the remainder of the key-on cycle
- Closed Loop- Enabled

Circuit Description

The Crankshaft Position sensor is a magnetic transducer mounted on the engine block adjacent to a pulse wheel located on the crankshaft. It determines crankshaft position by monitoring the pulse wheel. The Crankshaft Position sensor is used to measure engine RPM and its signal is used to synchronize the ignition and fuel systems. The ECM must see a valid Crankshaft position signal while running. If no signal is present for 800ms or longer, this fault will set.

DTC 142 Crank Sync Noise

Step	Action	Value(s)	Yes	No
1	Did you perform the On-Board (OBD) System Check?	-	Go to Step (2)	Go to OBD System Check Section
2	<ul style="list-style-type: none"> Check that the ECM ground terminals G1 and G2 are clean and tight Are the ground terminals G1 and G2 clean and tight?		Go to Step (3)	Repair the circuit as necessary. Refer to Wiring Repairs in Engine Electrical.
3	<ul style="list-style-type: none"> Key On, Engine OFF Disconnect the CKP (Crankshaft position) Sensor connector C009 Using A DVOM check for voltage at the CKP sensor connector pin A and engine ground Do you have voltage?	5.0 volts	Go to Step (4)	Repair the circuit as necessary. Refer to Wiring Repairs in Engine Electrical.
4	<ul style="list-style-type: none"> Key OFF Disconnect ECM connector C001 Using a DVOM check for continuity between CKP connector pin B and ECM connector pin 12 Do you have continuity between them? 		Go to Step (5)	Repair the circuit as necessary. Refer to Wiring Repairs in Engine Electrical.
5	<ul style="list-style-type: none"> Using a DVOM check for continuity between CKP connector pin C and ECM connector pin 11 Do you have continuity between them?		Go to Step (6)	Repair the circuit as necessary. Refer to Wiring Repairs in Engine Electrical.
6	<ul style="list-style-type: none"> Inspect the CKP connector C009 terminals for damage, corrosion or contamination Did you find a problem?		Repair the circuit as necessary. Refer to Wiring Repairs in Engine Electrical.	Go to Step (7)
7	<ul style="list-style-type: none"> Inspect the ECM connector C001 terminals 11,12 and 50 for damage, corrosion or contamination Did you find a problem		Repair the circuit as necessary. Refer to Wiring Repairs in Engine Electrical.	Go to step (8)
8	<ul style="list-style-type: none"> Replace CKP sensor using R&R procedure in Section 1E. Pay special attention to CKP sensor reluctor wheel inspection. Is the replacement complete?		Go to Step (10)	-
9	<ul style="list-style-type: none"> Replace ECM Is the replacement complete? 		Go to Step (11)	-

Step	Action	Value(s)	Yes	No
10	<ul style="list-style-type: none"> • Remove all test equipment except the DST. • Connect any disconnected components, fuses, etc. • Using the DST clear DTC information from the ECM. • Turn the ignition OFF and wait 30 seconds. • Start the engine and operate the vehicle to full operating temperature • Observe the MIL • Observe engine performance and driveability • After operating the engine within the test parameters of DTC-142 check for any stored codes. <p>Does the engine operate normally with no stored codes?</p>		System OK	Go to Step (9)
11	<ul style="list-style-type: none"> • Remove all test equipment except the DST. • Connect any disconnected components, fuses, etc. • Using the DST clear DTC information from the ECM. • Turn the ignition OFF and wait 30 seconds. • Start the engine and operate the vehicle to full operating temperature • Observe the MIL • Observe engine performance and driveability • After operating the engine within the test parameters of DTC-142 check for any stored codes. <p>Does the engine operate normally with no stored codes?</p>		System OK	Go to OBD System Check

DTC 143 Never Crank Sync At Start

Step	Action	Value(s)	Yes	No
1	Did you perform the On-Board (OBD) System Check?	-	Go to Step (2)	Go to OBD System Check Section
2	<ul style="list-style-type: none"> Check that the ECM ground terminals G1 and G2 are clean and tight Are the ground terminals G1 and G2 clean and tight?		Go to Step (3)	Repair the circuit as necessary. Refer to Wiring Repairs in Engine Electrical.
3	<ul style="list-style-type: none"> Key On, Engine OFF Disconnect the CKP (Crankshaft position) Sensor connector C009 Using A DVOM check for voltage at the CKP sensor connector pin A and engine ground Do you have voltage?	5.0 volts	Go to Step (4)	Repair the circuit as necessary. Refer to Wiring Repairs in Engine Electrical.
4	<ul style="list-style-type: none"> Key OFF Disconnect ECM connector C001 Using a DVOM check for continuity between CKP connector pin B and ECM connector pin 12 Do you have continuity between them? 		Go to Step (5)	Repair the circuit as necessary. Refer to Wiring Repairs in Engine Electrical.
5	<ul style="list-style-type: none"> Using a DVOM check for continuity between CKP connector pin C and ECM connector pin 11 Do you have continuity between them?		Go to Step (6)	Repair the circuit as necessary. Refer to Wiring Repairs in Engine Electrical.
6	<ul style="list-style-type: none"> Inspect the CKP connector C009 terminals for damage, corrosion or contamination Did you find a problem?		Repair the circuit as necessary. Refer to Wiring Repairs in Engine Electrical.	Go to Step (7)
7	<ul style="list-style-type: none"> Inspect the ECM connector C001 terminals 11,12 and 50 for damage, corrosion or contamination Did you find a problem		Repair the circuit as necessary. Refer to Wiring Repairs in Engine Electrical.	Go to step (8)
8	<ul style="list-style-type: none"> Replace CKP sensor using CKP R&R procedure in Section 1E. Pay special attention to CKP reluctor wheel inspection Is the replacement complete?		Go to Step (10)	-
9	<ul style="list-style-type: none"> Replace ECM Is the replacement complete?		Go to Step (11)	-

Step	Action	Value(s)	Yes	No
10	<ul style="list-style-type: none"> • Remove all test equipment except the DST. • Connect any disconnected components, fuses, etc. • Using the DST clear DTC information from the ECM. • Turn the ignition OFF and wait 30 seconds. • Start the engine and operate the vehicle to full operating temperature • Observe the MIL • Observe engine performance and driveability • After operating the engine within the test parameters of DTC-143 check for any stored codes. <p>Does the engine operate normally with no stored codes?</p>		System OK	Go to Step (9)
11	<ul style="list-style-type: none"> • Remove all test equipment except the DST. • Connect any disconnected components, fuses, etc. • Using the DST clear DTC information from the ECM. • Turn the ignition OFF and wait 30 seconds. • Start the engine and operate the vehicle to full operating temperature • Observe the MIL • Observe engine performance and driveability • After operating the engine within the test parameters of DTC-143 check for any stored codes. <p>Does the engine operate normally with no stored codes?</p>		System OK	Go to OBD System Check

DTC 211- Closed Loop Multiplier High (LPG)

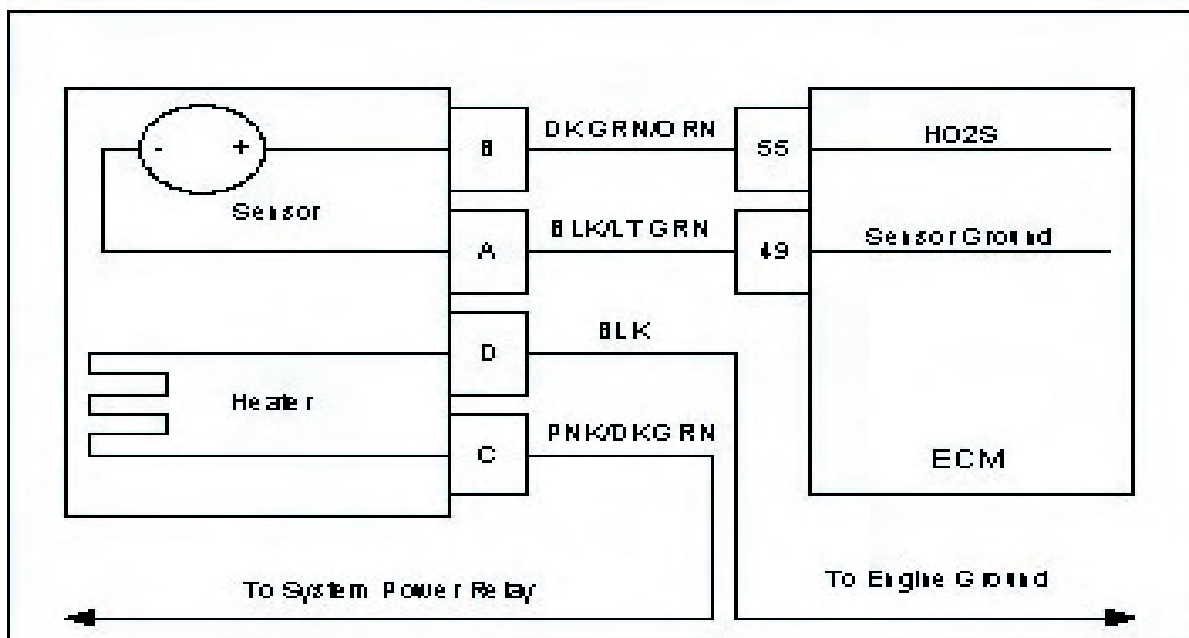

Conditions for Setting the DTC

- Heated Oxygen Sensor
- Functional Fault-Closed Loop multiplier out of range (at limit of 35%)
- MIL Disabled
- Adaptive-Disabled
- Closed Loop-Enabled

Circuit Description

The HO2S (Heated Oxygen Sensor) sensor is used to determine if the fuel flow to the engine is correct by measuring the oxygen content in the exhaust gas. The ECM uses this information to correct the fuel flow with the Closed Loop multiplier and the adaptive multiplier. This fault sets if the Closed Loop multiplier exceeds the limits of normal operation. When the multiplier cannot correctly modify the fuel flow within its limits, it is limited at 35%.

Diagnostic Aids

Always diagnose any other ECM codes that are present before beginning this diagnostic procedure.

Fuel System High secondary fuel pressure can cause the system to run rich. A worn fuel mixer, faulty 3-way pressure trim solenoid can also cause the system to run rich.

Fuel Quality A drastic variation in fuel quality (very high butane content) may cause the system to run rich. Be sure that the specified HD-5 or HD-10 motor fuel grade propane is used.

DTC 211- Closed Loop Multiplier High (LPG)

Step	Action	Value(s)	Yes	No
1	Did you perform the On-Board (OBD) System Check?	-	<i>Go to Step (2)</i>	<i>Go to OBD System Check Section</i>
2	<ul style="list-style-type: none"> • Key On, Engine Running • DST (Diagnostic Scan Tool) connected in System Data Mode • Run engine to full operating temperature and then idle for a minimum of 2 minutes Does DST display HO2S voltage fixed below 0.35 volts after 2 minutes of idle run time?		<i>Go to step (3)</i>	<i>Intermittent problem Go to Intermittent section</i>
3	<ul style="list-style-type: none"> • Key OFF • Disconnect ECM connector • Disconnect HO2S wire harness connector • Using a high impedance DVOM check for continuity between HO2S connector signal pin B and engine ground Do you have continuity?		Repair the circuit as necessary. Refer to Wiring Repairs in Engine Electrical.	<i>Go to Step (4)</i>
4	<ul style="list-style-type: none"> • Using a high impedance DVOM check for continuity between HO2S connector signal pin B and HO2S connector sensor ground pin A • Do you have continuity between them? 		Repair the circuit as necessary. Refer to Wiring Repairs in Engine Electrical.	<i>Go to Step (5)</i>
5	<ul style="list-style-type: none"> • Refer to Diagnostic aids for DTC 211 Did you check the diagnostic Aids for DTC 211?		<i>Go to Step (6)</i>	
6	<ul style="list-style-type: none"> • Replace HO2S sensor Is the replacement complete?		<i>Go to Step (7)</i>	

Step	Action	Value(s)	Yes	No
7	<ul style="list-style-type: none"> • Remove all test equipment except the DST. • Connect any disconnected components, fuses, etc. • Using the DST clear DTC information from the ECM. • Turn the ignition OFF and wait 30 seconds. • Start the engine and operate the vehicle to full operating temperature • Observe the MIL • Observe engine performance and driveability • After operating the engine within the test parameters of DTC-211 check for any stored codes. <p>Does the engine operate normally with no stored codes?</p>		System OK	Go to OBD System Check

212-HO2S Open/Inactive

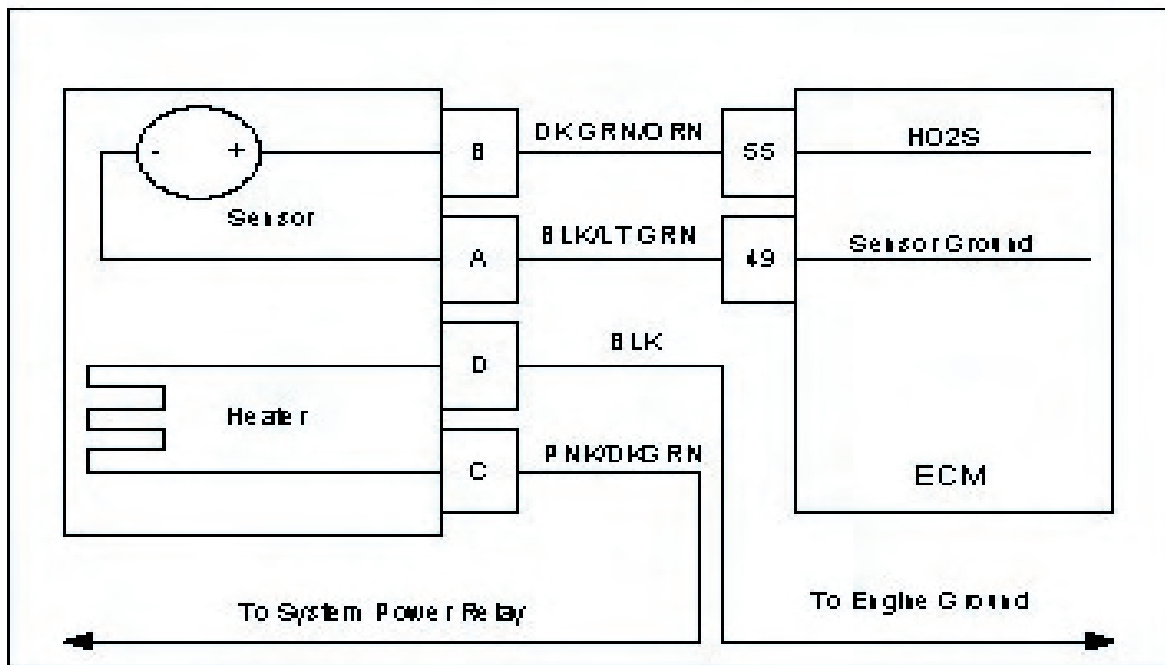

Conditions for Setting the DTC

- Heated Oxygen Sensor
- Check condition- Engine running
- Fault condition- HO2S cold persistently more than 120 seconds
- MIL- On during active fault and for 1 second after active fault
- Adaptive- Disabled during active fault
- Closed Loop- Disabled during active fault

Circuit Description

The HO2S sensor is used to determine if the fuel flow to the engine is correct by measuring the oxygen content in the exhaust gas. The ECM uses this information to correct the fuel flow with the Closed Loop multiplier and the Adaptive multiplier.

This fault will set if HO2S is cold, non-responsive, or inactive for 120 seconds or longer.

DTC 212- HO2S Open/Inactive

Step	Action	Value(s)	Yes	No
1	Did you perform the On-Board (OBD) System Check?	-	Go to Step (2)	Go to OBD System Check Section
2	<ul style="list-style-type: none"> Key ON, Engine Running DST (Diagnostic Scan Tool) connected in System Data Mode Run engine to full operating temperature and then idle for a minimum of 2 minutes <p>Does DST display HO2S voltage fixed between 0.4 and 0.5 volts after 2 minutes of idle run time?</p>		Go to Step (5)	Go to Step (3)
3	<ul style="list-style-type: none"> Back probe HO2S wire harness connector and check for voltage between HO2S connector heater ground pin D and battery voltage positive. <p>Do you have power?</p>		Go to step (4)	Repair the circuit as necessary. Refer to Wiring Repairs in Engine Electrical.
4	<ul style="list-style-type: none"> Back probe HO2S wire harness connector and check for voltage between HO2S connector heater power pin C and engine ground. <p>Do you have power?</p>		Go to step (7)	Repair the circuit as necessary. Check System Power Relay circuit. Refer to Wiring Repairs in Engine Electrical.
5	<ul style="list-style-type: none"> Key OFF Disconnect HO2S connector and ECM connector. Key ON Check for continuity between HO2S sensor connector ground pin A and ECM HO2S sensor ground PIN 49. <p>Do you have continuity between them?</p>		Go to Step (6)	Repair the circuit as necessary. Refer to Wiring Repairs in Engine Electrical.
6	<ul style="list-style-type: none"> Check for continuity between HO2S sensor connector signal pin B and ECM connector HO2S signal pin 55 <p>Do you have continuity between them?</p>		Go to Step (8)	Repair the circuit as necessary. Refer to Wiring Repairs in Engine Electrical.
7	Replace HO2S Sensor		Go to Step (9)	-
8	<ul style="list-style-type: none"> Inspect ECM connector pins 49 and 55 for damage, corrosion or contamination Inspect HO2S connector terminals A, B, C and D for damage, corrosion or contamination <p>Did you find a problem?</p>		Repair the circuit as necessary. Refer to Wiring Repairs in Engine Electrical.	Go to Step (7)

Step	Action	Value(s)	Yes	No
9	<ul style="list-style-type: none"> • Remove all test equipment except the DST. • Connect any disconnected components, fuses, etc. • Using the DST clear DTC information from the ECM. • Turn the ignition OFF and wait 30 seconds. • Start the engine and operate the vehicle to full operating temperature • Observe the MIL • Observe engine performance and driveability • After operating the engine within the test parameters of DTC-212 check for any stored codes. <p>Does the engine operate normally with no stored codes?</p>		System OK	Go to <i>OBD System Check</i>

DTC 221-Closed Loop Multiplier High (Gasoline)

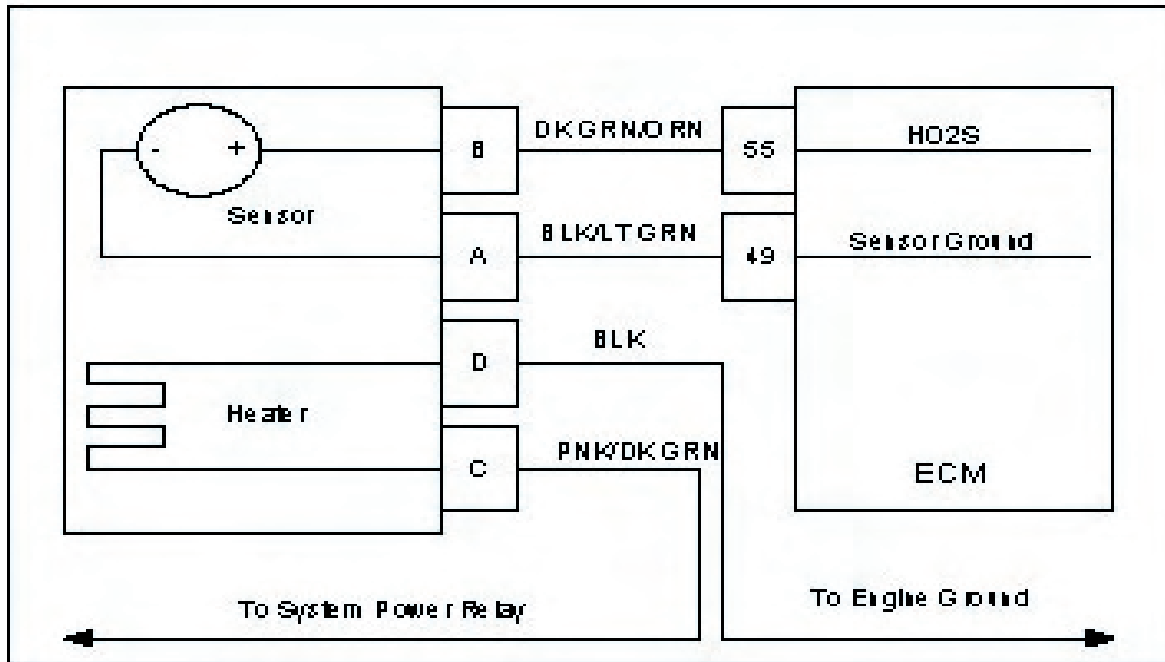

Conditions for Setting the DTC

- Heated Oxygen Sensor
- Functional Fault-Closed Loop multiplier out of range (at limit of 35%)
- MIL-On during active fault
- Adaptive-Enabled
- Closed Loop-Enabled

Circuit Description

The HO2S sensor is used to determine if the fuel flow to the engine is correct by measuring the oxygen content in the exhaust gas. The ECM uses this information to correct the fuel flow with the Closed Loop multiplier and the Adaptive multiplier.

This fault sets if the Closed Loop multiplier exceeds the limits of normal operation. When the multiplier cannot correctly modify the fuel flow within its limits, the limit is enforced.

DTC 221 Closed Loop Multiplier High (Gasoline)

Step	Action	Value(s)	Yes	No
1	Did you perform the On-Board (OBD) System Check?	-	Go to Step (2)	Go to OBD System Check Section
2	<ul style="list-style-type: none"> • Key On, Engine Running • DST (Diagnostic Scan Tool) connected in System Data Mode • Run engine to full operating temperature and then idle for a minimum of 2 minutes <p>Does DST display HO2S voltage fixed below 0.35 volts after 2 minutes of idle run time?</p>		Go to step (3)	Intermittent problem Go to Intermittent section
3	<ul style="list-style-type: none"> • Key OFF • Disconnect HO2S sensor wire harness connector • Disconnect ECM connector • Using a high impedance DVOM Check for continuity between HO2S connector signal pin B and engine ground <p>Do you have continuity?</p>		Repair the circuit as required Refer to Wiring Repairs in Engine Electrical.	Go to Step (4)
4	<ul style="list-style-type: none"> • Using a high impedance DVOM Check for continuity between HO2S connector signal pin B and HO2S sensor ground pin A <p>Do you have continuity?</p>		Repair the circuit as required Refer to Wiring Repairs in Engine Electrical.	Go to Step (5)
5	<ul style="list-style-type: none"> • Refer to Diagnostic aids for DTC 221 <p>Did you check the diagnostic Aids for DTC 221?</p>		Go to Step (6)	-
6	<ul style="list-style-type: none"> • Replace HO2S sensor <p>Is the replacement complete?</p>		Go to Step (7)	-
7	<ul style="list-style-type: none"> • Remove all test equipment except the DST. • Connect any disconnected components, fuses, etc. • Using the DST clear DTC information from the ECM. • Turn the ignition OFF and wait 30 seconds. • Start the engine and operate the vehicle to full operating temperature • Observe the MIL • Observe engine performance and driveability • After operating the engine within the test parameters of DTC-221 check for any stored codes. <p>Does the engine operate normally with no stored codes?</p>			

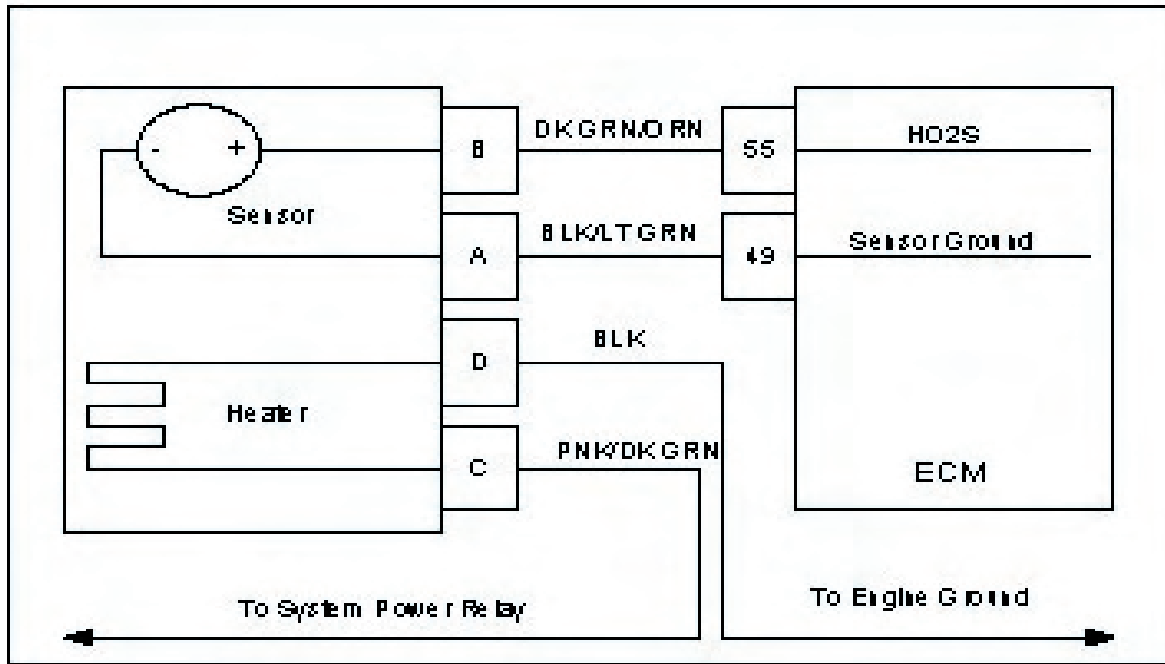
DTC 222- Closed Loop Multiplier Low (Gasoline)**Conditions for Setting the DTC**

- Heated Oxygen Sensor
- Functional Fault-Closed Loop multiplier out of range (at limit of -35%)
- MIL-On during active fault and for one update after active fault
- Adaptive-Enabled
- Closed Loop-Enabled

Circuit Description

The HO2S (Heated Oxygen Sensor) sensor is used to determine if the fuel flow to the engine is correct by measuring the oxygen content in the exhaust gas. The ECM uses this information to correct the fuel flow with the Closed Loop multiplier and the adaptive multiplier. This fault sets if the Closed Loop multiplier exceeds the limits of normal operation. When the multiplier cannot correctly modify the fuel flow within its limits, it is limited at -35%.

Diagnostic Aids

Always diagnose any other ECM codes that are present before beginning this diagnostic procedure.

Fuel System The system will be rich if an injector fails in an open manner. High fuel pressure due to a faulty fuel regulator or obstructed fuel return line will cause the system to run rich.

Ignition noise open or poor ground circuit to or in the ignition system or ECM may cause EMI (Electromagnetic interference). This noise could be interpreted by the ECM as ignition pulses, and the sensed RPM becomes higher than the actual speed. The ECM then delivers too much fuel, causing the system to run rich.

MAP Sensor A higher manifold pressure than normal can cause the system to go rich. Temporarily disconnecting the MAP Sensor will allow the ECM to set a default value for MAP.

IAT Sensor Check for a skewed sensor that could cause the ECM to sense lower than actual temperature of incoming air. This can cause a rich exhaust condition.

ECT Sensor Check for a skewed sensor that could cause the ECM to sense engine temperature colder than it actually is. This could also cause a rich exhaust condition.

DTC 222- Closed Loop Multiplier Low (Gasoline)

Step	Action	Value(s)	Yes	No
1	Did you perform the On-Board (OBD) System Check?	-	<i>Go to Step (2)</i>	<i>Go to OBD System Check Section</i>
2	<ul style="list-style-type: none"> • Key On, Engine Running • DST (Diagnostic Scan Tool) connected in System Data Mode • Run engine to full operating temperature and then idle for a minimum of 2 minutes Does DST display HO2S voltage fixed above 0.7 volts after 2 minutes of idle run time?		<i>Go to step (3)</i>	<i>Intermittent problem</i> <i>Go to Intermittent section</i>
3	<ul style="list-style-type: none"> • Key OFF • Disconnect HO2S wire harness connector • Disconnect ECM wiring harness connector • Key ON • Using a high impedance DVOM check for voltage between HO2S connector signal pin B and engine ground Do you have voltage?		<i>Repair the circuit as required</i> <i>Refer to Wiring Repairs in Engine Electrical.</i>	<i>Refer to Diagnostic Aids for DTC 222</i>

DTC 224- Closed Loop Multiplier Low (LPG)

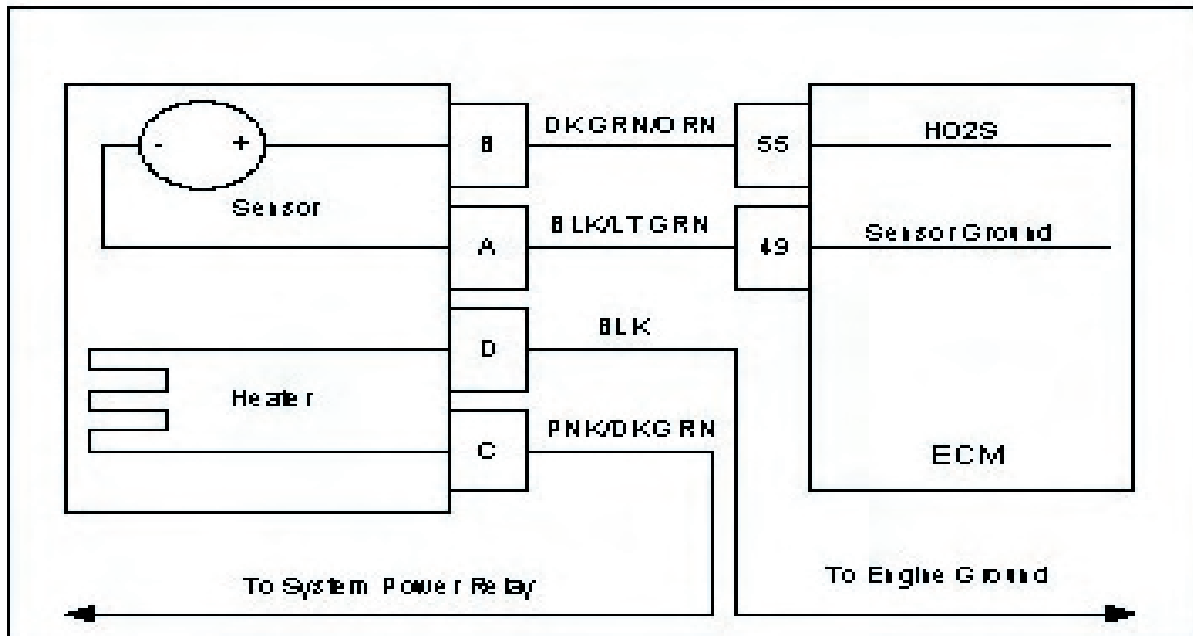

Conditions for Setting the DTC

- Heated Oxygen Sensor
- Functional Fault-Closed Loop multiplier out of range (at limit of -35%)
- MIL Disabled
- Adaptive-Disabled
- Closed Loop-Enabled

Circuit Description

The HO2S (Heated Oxygen Sensor) sensor is used to determine if the fuel flow to the engine is correct by measuring the oxygen content in the exhaust gas. The ECM uses this information to correct the fuel flow with the Closed Loop multiplier and the adaptive multiplier. This fault sets if the Closed Loop multiplier exceeds the limits of normal operation. When the multiplier cannot correctly modify the fuel flow within its limits, it is limited at -35%.

Diagnostic Aids

Always diagnose any other ECM codes that are present before beginning this diagnostic procedure.

Fuel System High secondary fuel pressure can cause the system to run rich. A worn fuel mixer, faulty PTV (pressure trim valve) or FTV (fuel trim valve) can also cause the system to run rich.

Fuel Quality A drastic variation in fuel quality (very high butane content) may cause the system to run rich. Be sure that the specified HD-5 or HD-10 motor fuel grade propane is used.

DTC 224- Closed Loop Multiplier Low (LPG)

Step	Action	Value(s)	Yes	No
1	Did you perform the On-Board (OBD) System Check?	-	Go to Step (2)	Go to OBD System Check Section
2	<ul style="list-style-type: none"> • Key On, Engine Running • DST (Diagnostic Scan Tool) connected in System Data Mode • Run engine to full operating temperature and then idle for a minimum of 2 minutes <p>Does DST display HO2S voltage fixed above 0.7 volts after 2 minutes of idle run time?</p>		Go to step (3)	Intermittent problem Go to Intermittent section
3	<ul style="list-style-type: none"> • Key OFF • Disconnect HO2S wire harness connector • Disconnect ECM wiring harness connector • Key ON • Using a high impedance DVOM check for voltage between HO2S connector signal pin B and engine ground <p>Do you have voltage?</p>		Repair wire harness shorted signal to voltage Refer to Wiring Repairs in Engine Electrical.	Refer to Diagnostic Aids for DTC 224

DTC 241-Adaptive Lean Fault (high limit-gasoline)

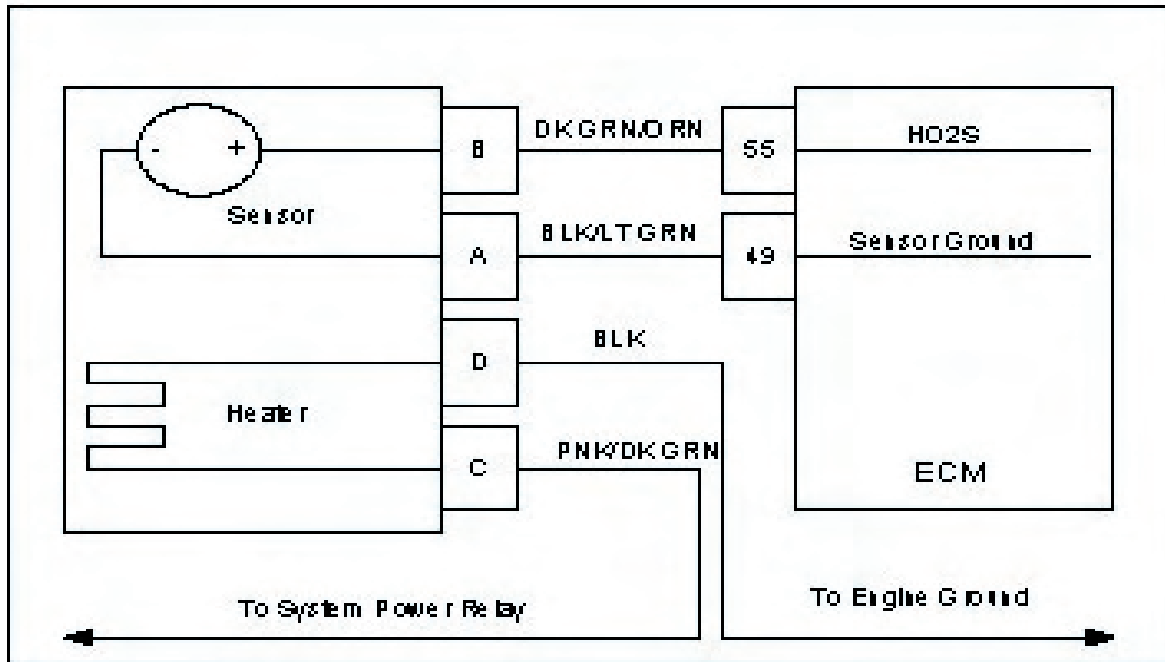

Conditions for Setting the DTC

- Heated Oxygen Sensor
- Functional Fault-Adaptive multiplier out of range (greater than 30%)
- MIL-On during active adaptive limit condition
- Adaptive-Enabled
- Closed Loop-Enabled

Circuit Description

The HO₂S sensor is used to determine if the fuel flow to the engine is correct by measuring the oxygen content in the exhaust gas. The ECM uses this information to correct the fuel flow with the Closed Loop multiplier and the Adaptive multiplier. This fault sets if the Adaptive multiplier exceeds the limits of normal operation.

Diagnostic Aids

If any other DTCs are present, diagnose those first

Oxygen Sensor Wire Heated Oxygen sensor wires may be mis-routed and contacting the exhaust manifold.

Vacuum Leaks Large vacuum leaks and crankcase leaks can cause a lean exhaust condition at especially at light load.

Injectors System will be lean if an injector driver or driver circuit fails open. The system will also be lean if an injector fails in a closed manner or is dirty.

Fuel Pressure Low fuel pressure, faulty fuel injector or damaged fuel pump assembly can cause fuel system to run lean

Exhaust Leaks If there is an exhaust leak, outside air can be pulled into the exhaust and past the O₂ sensor causing a false lean.

Fuel Quality Contaminated or spoiled fuel can cause the fuel system to be lean.

Ground Problem ECM grounds must be good battery or engine ground.

DTC 241 Adaptive Lean Fault (High Limit Gasoline)

Step	Action	Value(s)	Yes	No
1	<ul style="list-style-type: none"> Perform the On-Board (OBD) System Check? Are any other DTCs present?		<i>Go to Step (3)</i>	<i>Go to Step (2)</i>
2	Visually and physically check the following items: <ul style="list-style-type: none"> The air intake duct for being collapsed or restricted The air filter for being plugged The HO2S sensor installed securely and the wire leads not contacting the exhaust manifold or ignition wires ECM grounds for being clean and tight. Refer to Section 1C Engine Electrical Power and Ground Distribution Fuel System Diagnostics. Refer to Section 1B Fuel System Diagnostics Was a repair made?		<i>Go to Step (8)</i>	<i>Go to Step (4)</i>
3	<ul style="list-style-type: none"> Diagnose any other DTC codes before proceeding with this chart. Have any other DTC codes been detected, diagnosed and repaired?		<i>Go to Step (8)</i>	<i>Go to step (4)</i>
4	<ul style="list-style-type: none"> Key ON Engine running Back probe the HO2S sensor connector heater terminals D for negative and C for positive Using a DVOM check for voltage Do you have voltage? 	Battery voltage	<i>Go to Step (5)</i>	Repair the circuit as necessary. Refer to Wiring Repairs in Engine Electrical.
5	<ul style="list-style-type: none"> Key OFF Disconnect HO2S sensor wire harness connector Disconnect ECM wire harness connector Key ON Using a high impedance DVOM check for continuity between HO2S connector signal pin B and engine ground Do you have voltage?		Repair the circuit as necessary. Refer to Wiring Repairs in Engine Electrical.	<i>Go to Step (6)</i>
6	<ul style="list-style-type: none"> Using a high impedance DVOM check for continuity between HO2S connector sensor ground pin A and HO2S signal pin B Do you have continuity? 		Repair the circuit as necessary. Refer to Wiring Repairs in Engine Electrical.	<i>Go to Step (7)</i>
7	<ul style="list-style-type: none"> Replace HO2S sensor Is the replacement complete?		<i>Go to Step (8)</i>	-

Step	Action	Value(s)	Yes	No
8	<ul style="list-style-type: none">• Remove all test equipment except the DST.• Connect any disconnected components, fuses, etc.• Using the DST clear DTC information from the ECM.• Turn the ignition OFF and wait 30 seconds.• Start the engine and operate the vehicle to full operating temperature• Observe the MIL• Observe engine performance and driveability• After operating the engine within the test parameters of DTC-241 check for any stored codes. Does the engine operate normally with no stored codes?		System OK	Go to <i>OBD System Check</i>

DTC 242-Adaptive Rich Fault (low limit-gasoline)

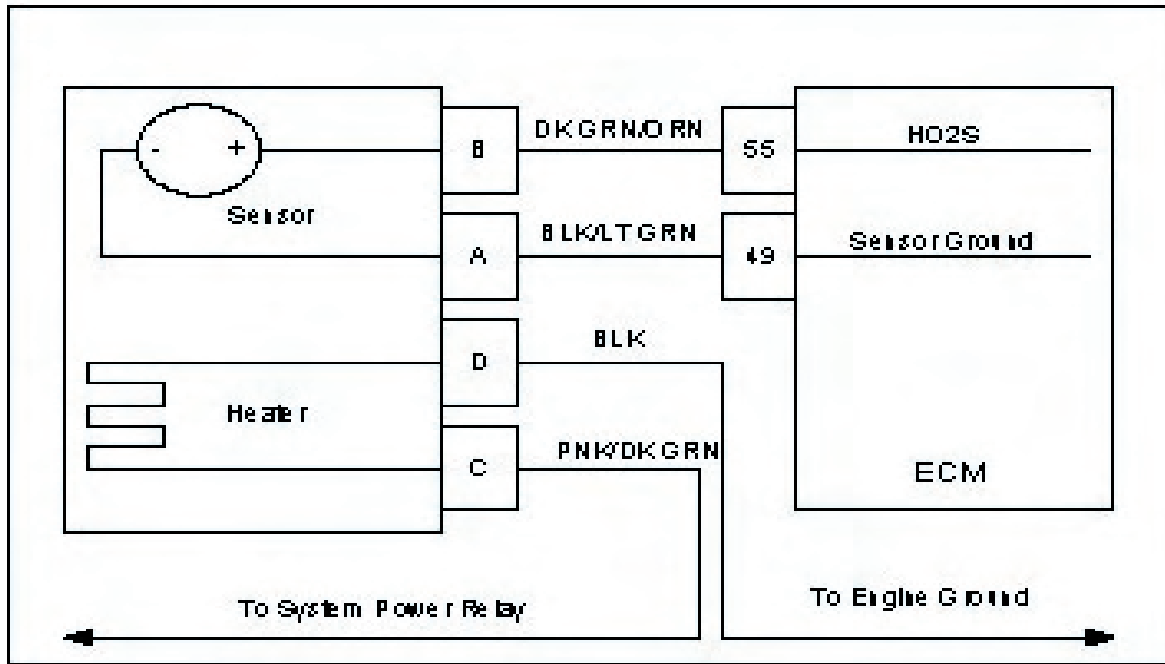

Conditions for Setting the DTC

- Heated Oxygen Sensor
- Functional Fault-Adaptive multiplier out of range (at limit of -30%)
- MIL-On during active adaptive limit condition
- Adaptive-Enabled
- Closed Loop-Enabled

Circuit Description

The HO2S sensor is used to determine if the fuel flow to the engine is correct by measuring the oxygen content in the exhaust gas. The ECM uses this information to correct the fuel flow with the Closed Loop multiplier and the Adaptive multiplier. This fault sets if the Adaptive multiplier exceeds the limits of normal operation.

Diagnostic Aids

Always diagnose any other ECM codes that are present before beginning this diagnostic procedure.

Fuel System The system will be rich if an injector fails in an open manner. High fuel pressure due to a faulty fuel regulator or obstructed fuel return line will cause the system to run rich.

Ignition noise open or poor ground circuit to or in the ignition system or ECM may cause EMI (Electromagnetic interference). This noise could be interpreted by the ECM as ignition pulses, and the sensed RPM becomes higher than the actual speed. The ECM then delivers too much fuel, causing the system to go rich.

TMAP Sensor A higher manifold pressure than normal can cause the system to go rich. Temporarily disconnecting the MAP Sensor will allow the ECM to set a default value for MAP.

IAT Sensor Check for a shifted sensor that could cause the ECM to sense lower than actual temperature of incoming air. This can cause a rich exhaust condition.

ECT Sensor Check for a skewed sensor that could cause the ECM to sense engine temperature colder than it actually is. This could also cause a rich exhaust condition.

DTC 242 Adaptive Rich Fault (Low Limit Gasoline)

Step	Action	Value(s)	Yes	No
1	<ul style="list-style-type: none"> • Perform the On-Board (OBD) System Check? Are any other DTCs present?		Go to Step (3)	Go to Step (2)
2	Visually and physically check the following items: <ul style="list-style-type: none"> • The air intake duct for being collapsed or restricted • The air filter for being plugged • The HO2S sensor installed securely and the wire leads not contacting the exhaust manifold or ignition wires • ECM grounds for being clean and tight. Refer to Section 1C Engine Electrical Power and Ground Distribution • Fuel System Diagnostics. Refer to Section 1B Fuel System Diagnostics Was a repair made?		Go to Step (7)	Go to Step (4)
3	<ul style="list-style-type: none"> • Diagnose any other DTC codes before proceeding with this chart. Have any other DTC codes been detected, diagnosed and repaired?		Go to Step (7)	Go to step (4)
4	<ul style="list-style-type: none"> • Key OFF • Disconnect HO2S sensor wire harness connector • Disconnect ECM wire harness connector • Key ON • Using a DVOM check for voltage at HO2S connector signal pin B and engine ground Do you have voltage?		Repair the circuit as necessary. Refer to Wiring Repairs in Engine Electrical.	Go to Step (5)
5	<ul style="list-style-type: none"> • Replace HO2S sensor Is the replacement complete?		Go to Step (7)	-
7	<ul style="list-style-type: none"> • Remove all test equipment except the DST. • Connect any disconnected components, fuses, etc. • Using the DST clear DTC information from the ECM. • Turn the ignition OFF and wait 30 seconds. • Start the engine and operate the vehicle to full operating temperature • Observe the MIL • Observe engine performance and driveability • After operating the engine within the test parameters of DTC-242 check for any stored codes. Does the engine operate normally with no stored codes?		System OK	Go to OBD System Check

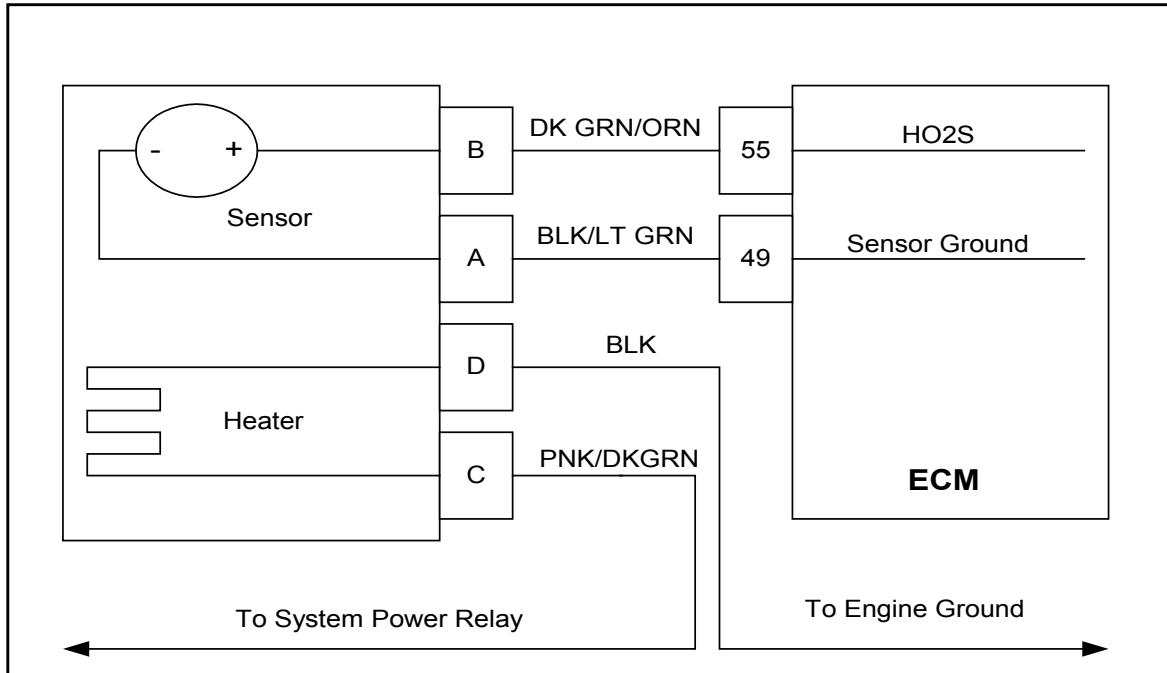
DTC 243-Adaptive Learn High (LPG)**Conditions for Setting the DTC**

- Heated Oxygen Sensor
- Check Condition- Engine Running
- Fault Condition- Adaptive multiplier out of range (greater than 30%)
- MIL- Disabled
- Adaptive- Enabled
- Closed Loop- Enabled

Circuit Description

The HO2S sensor is used to determine if the fuel flow to the engine is correct by measuring the oxygen content in the exhaust gas. The ECM uses this information to correct the fuel flow with the Closed Loop multiplier and Adaptive multiplier. This fault will set if the adaptive multiplier exceeds the limits of normal operation.

Diagnostic Aids**If any other DTCs are present, diagnose those first**

Oxygen Sensor Wire Heated Oxygen sensor wires may be mis-routed and contacting the exhaust manifold.

Vacuum Leaks Large vacuum leaks and crankcase leaks can cause a lean exhaust condition at especially at light load.

Injectors System will be lean if an injector driver or driver circuit fails open. The system will also be lean if an injector fails in a closed manner or is dirty.

Fuel Pressure Low fuel pressure, faulty fuel injector or damaged fuel pump assembly can cause fuel system to run lean

Exhaust Leaks If there is an exhaust leak, outside air can be pulled into the exhaust and past the O2 sensor causing a false lean condition.

Fuel Quality Contaminated or spoiled fuel can cause the fuel system to be lean.

Ground Problem ECM grounds must be good battery or engine ground.

DTC 243 Adaptive Learn High (LPG)

Step	Action	Value(s)	Yes	No
1	<ul style="list-style-type: none"> • Perform the On-Board (OBD) System Check? Are any other DTCs present?		<i>Go to Step (3)</i>	<i>Go to Step (2)</i>
2	Visually and physically check the following items: <ul style="list-style-type: none"> • The air intake duct for being collapsed or restricted • The air filter for being plugged • The HO2S sensor installed securely and the wire leads not contacting the exhaust manifold or ignition wires • ECM grounds for being clean and tight. Refer to Section 1C Engine Electrical Power and Ground Distribution • Fuel System Diagnostics. Refer to Section 1B Fuel System Diagnostics Was a repair made?		<i>Go to Step (7)</i>	<i>Go to Step (4)</i>
3	<ul style="list-style-type: none"> • Diagnose any other DTC codes before proceeding with this chart. Have any other DTC codes been detected, diagnosed and repaired?		<i>Go to Step (7)</i>	<i>Go to step (4)</i>
4	<ul style="list-style-type: none"> • Key ON Engine running • Using a DVOM back probe the HO2S sensor connector heater circuit pin C for positive and D for negative. check for voltage Do you have voltage?	Battery voltage	<i>Go to Step (5)</i>	Repair the circuit as necessary. Refer to Wiring Repairs in Engine Electrical.
5	<ul style="list-style-type: none"> • Key OFF • Disconnect HO2S sensor wire harness connector • Disconnect ECM wire harness connector • Key ON • Using a DVOM check for voltage at HO2S connector signal pin B and engine ground Do you have voltage?		Repair the circuit as necessary. Refer to Wiring Repairs in Engine Electrical.	<i>Go to Step (6)</i>
6	<ul style="list-style-type: none"> • Replace HO2S sensor Is the replacement complete?		<i>Go to Step (7)</i>	-
7	<ul style="list-style-type: none"> • Remove all test equipment except the DST. • Connect any disconnected components, fuses, etc. • Using the DST clear DTC information from the ECM. • Turn the ignition OFF and wait 30 seconds. • Start the engine and operate the vehicle to full operating temperature • Observe the MIL • Observe engine performance and driveability • After operating the engine within the test parameters of DTC-243 check for any stored codes. Does the engine operate normally with no stored codes?		System OK	<i>Go to OBD System Check</i>

DTC 244-Adaptive Learn Low (LPG)

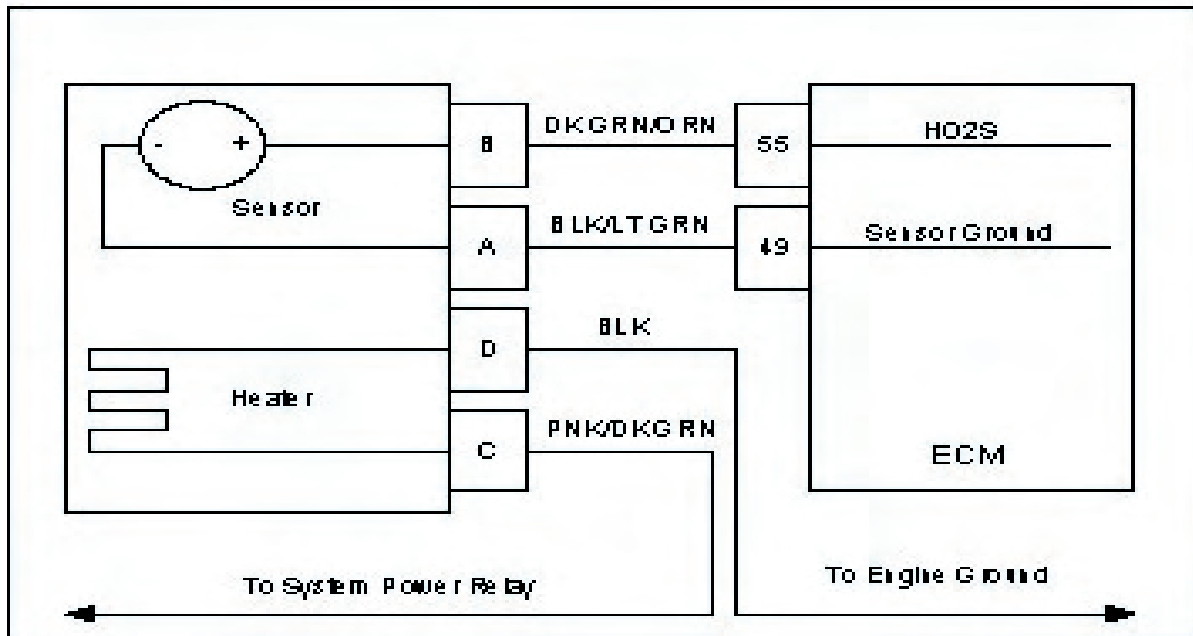

Conditions for Setting the DTC

- Heated Oxygen Sensor
- Check Condition- Engine running
- Fault Condition- Adaptive multiplier out of range (at limit of -30%)
- MIL-Disabled
- Adaptive- Enabled
- Closed Loop- Enabled

Circuit Description

The HO2S sensor is used to determine if the fuel flow to the engine is correct by measuring the oxygen content in the exhaust gas. The ECM uses this information to correct the fuel flow with the Closed Loop multiplier and Adaptive multiplier. This fault will set if the adaptive multiplier exceeds the limits of normal operation.

Diagnostic Aids

Always diagnose any other ECM codes that are present before beginning this diagnostic procedure.

Fuel System High secondary fuel pressure will cause the system to run rich. A worn fuel mixer, faulty 3-way pressure trim solenoid can also cause the system to run rich.

Fuel Quality A drastic variation in fuel quality (very high butane content) may cause the system to run rich. Be sure that the specified HD-5 or HD-10 motor fuel grade propane is used.

DTC 244 Adaptive Learn Low (LPG)

Step	Action	Value(s)	Yes	No
1	<ul style="list-style-type: none"> Perform the On-Board (OBD) System Check? Are any other DTCs present?		Go to Step (3)	Go to Step (2)
2	Visually and physically check the following items: <ul style="list-style-type: none"> The air intake duct for being collapsed or restricted The air filter for being plugged ECM grounds for being clean and tight. Refer to Section 1C Engine Electrical Power and Ground Distribution Fuel System Diagnostics. Refer to Section 1B Fuel System Diagnostics Was a repair made?		Go to Step (7)	Go to Step (4)
3	<ul style="list-style-type: none"> Diagnose any other DTC codes before proceeding with this chart. Have any other DTC codes been detected, diagnosed and repaired?		Go to Step (7)	Go to step (4)
4	<ul style="list-style-type: none"> Key OFF Disconnect HO2S sensor wire harness connector Disconnect ECM wire harness connector Key ON Using a DVOM check for voltage at HO2S connector signal pin B and engine ground Do you have voltage?		Repair the circuit as necessary. Refer to Wiring Repairs in Engine Electrical.	Go to Step (5)
5	<ul style="list-style-type: none"> Replace HO2S sensor Is the replacement complete?		Go to Step (7)	-
7	<ul style="list-style-type: none"> Remove all test equipment except the DST. Connect any disconnected components, fuses, etc. Using the DST clear DTC information from the ECM. Turn the ignition OFF and wait 30 seconds. Start the engine and operate the vehicle to full operating temperature Observe the MIL Observe engine performance and driveability After operating the engine within the test parameters of DTC-244 check for any stored codes. Does the engine operate normally with no stored codes?		System OK	Go to OBD System Check

DTC 262-System Voltage Low

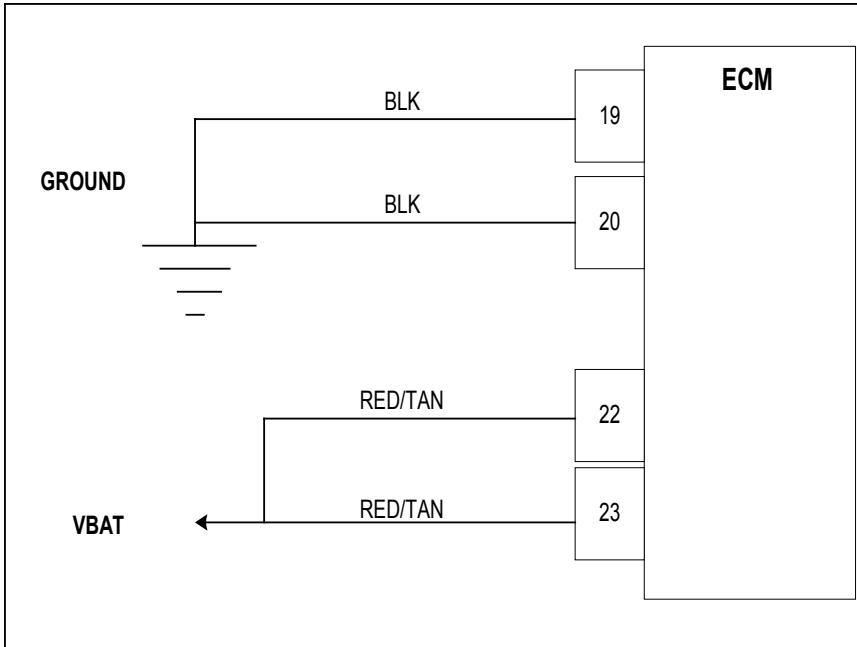

Conditions for Setting the DTC

- System Voltage to ECM
- Check Condition-Key on and RPM greater than 1500
- Fault Condition-Battery voltage at ECM less than 9.0 volts continuously for 5 secondsV
- MIL-On for active fault and for 10 seconds after active fault
- Adaptive-Disabled for remainder of key on cycle
- Closed Loop-Enabled

Circuit Description

The battery voltage powers the ECM and must be measured to correctly operate injector drivers, fuel trim valves and ignition coils. This fault will set if the ECM detects system voltage less than 9.0 for 5 seconds or longer while the alternator should be charging. The adaptive learn is disabled.

DTC 262- System Voltage Low

Step	Action	Value(s)	Yes	No
1	Did you perform the On-Board (OBD) System Check?	-	Go to Step (2)	Go to OBD System Check Section
2	<ul style="list-style-type: none"> Key On, Engine Running DST (Diagnostic Scan Tool) connected in System Data Mode Does DST display system voltage greater than 9.0 volts?	-	<i>Intermittent problem</i> Go to Engine Electrical Intermittent section	Go to Step (3)
3	<ul style="list-style-type: none"> Check battery condition Is it OK?	-	Go to Step (4)	Replace Battery
4	<ul style="list-style-type: none"> Check charging system Is it Ok?	-	Go to Step (5)	Repair charging System
5	<ul style="list-style-type: none"> Back probe ECM connector pins 22 and 23 Measure voltage with DVOM between each pin and engine ground Is the voltage greater than 9.0 volts?	-	<i>Repair ECM Ground circuit.</i> Go to Power and Ground section in engine Electrical	Go to Step (6)
6	<ul style="list-style-type: none"> Back probe ECM connector pins 19 and 20 Measure voltage with DVOM between each pin and battery voltage Is the voltage greater than 9.0 volts?	-	<i>Repair ECM power circuit.</i> Go to Power and Ground section in engine Electrical	Go to step (7)
7	Replace ECM Is the replacement complete?	-	Go to Step (8)	-
8	<ul style="list-style-type: none"> Remove all test equipment except the DST. Connect any disconnected components, fuses, etc. Using the DST clear DTC information from the ECM. Turn the ignition OFF and wait 30 seconds. Start the engine and operate the vehicle to full operating temperature Observe the MIL Observe engine performance and driveability After operating the engine within the test parameters of DTC-261 check for any stored codes. Does the engine operate normally with no stored codes?	-	System OK	Go to OBD System Check

DTC 261-System Voltage High

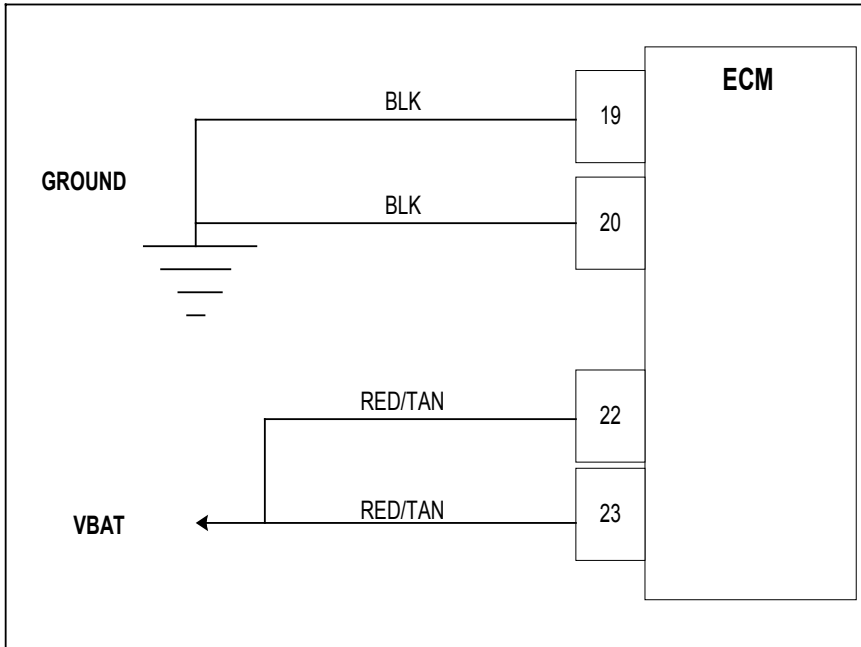

Conditions for Setting the DTC

- System Voltage to ECM
- Check Condition-Cranking or Running
- Fault Condition-Switched battery voltage at ECM greater than 18 volts for 3 seconds
- MIL-On for active fault and for 5 seconds after active fault
- Adaptive-Disabled for remainder of key on cycle
- Closed Loop-Enabled

Circuit Description

The battery voltage powers the ECM and must be measured to correctly operate injector drivers, trim valves and ignition coils. This fault will set if the ECM detects voltage greater than 18 volts for 3 seconds at anytime the engine is cranking or running. The adaptive learn is disabled. The ECM will shut down with internal protection if the system voltage exceeds 26 volts. The ECM fuse will then open.

DTC 261- System Voltage High

Step	Action	Value(s)	Yes	No
1	Did you perform the On-Board (OBD) System Check?	-	Go to Step (2)	Go to OBD System Check Section
2	<ul style="list-style-type: none"> • Key On, Engine Running • DST (Diagnostic Scan Tool) connected in System Data Mode • Run engine greater than 1500 rpm. <p>Does DST display system voltage less than 18 volts?</p>	-	Intermittent problem Go to Engine Electrical Intermittent section	Go to Step (3)
3	<ul style="list-style-type: none"> • Check voltage at battery terminals with DVOM with engine speed greater than 1500 rpm <p>Is it greater than 18 volts?</p>	-	Go to Step (4)	Go to Step (5)
4	<ul style="list-style-type: none"> • Repair the charging system <p>Has the charging system been repaired?</p>	-	Go to Step (6)	-
5	<ul style="list-style-type: none"> • Replace ECM <p>Is the replacement complete?</p>	-	Go to Step (6)	-
6	<ul style="list-style-type: none"> • Remove all test equipment except the DST. • Connect any disconnected components, fuses, etc. • Using the DST clear DTC information from the ECM. • Turn the ignition OFF and wait 30 seconds. • Start the engine and operate the vehicle to full operating temperature • Observe the MIL • Observe engine performance and driveability • After operating the engine within the test parameters of DTC-262 check for any stored codes. <p>Does the engine operate normally with no stored codes?</p>	-	System OK	Go to OBD System Check

DTC 511-COP Failure

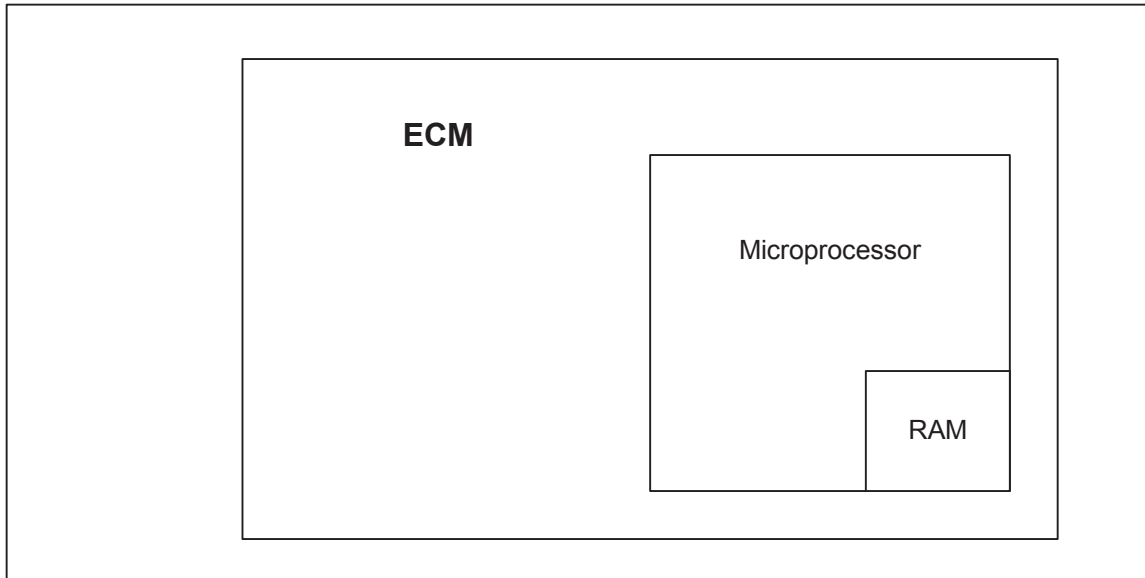

Conditions for Setting the DTC

- Engine Control Module
- Check Condition- Key on
- Fault Condition- Internal microprocessor error
- MIL- On until code is cleared by technician
- Adaptive- Disabled for the remainder of the key-on cycle
- Closed Loop- Enabled
- Power Derate (level 2 until fault is cleared manually)

Circuit Description

The ECM has checks that must be satisfied each time an instruction is executed. Several different things can happen within the microprocessor that will cause this fault. The ECM will reset itself in the event this fault is set, and the MIL will be on until the code is cleared. During this active fault, Power Derate (level 2) will be enforced. When this is enforced, maximum throttle position will be 20%. This is enforced until the fault is manually cleared.

DTC 511 COP Failure

Step	Action	Value(s)	Yes	No
1	Did you perform the On-Board (OBD) System Check?	-	Go to Step (2)	Go to OBD System Check Section
2	<ul style="list-style-type: none"> • Key On, Engine Running • DST (Diagnostic Scan Tool) connected in • System Data Mode • Clear system fault code Does DTC 511 reset with the engine idling?		Go to Step (3)	Intermittent problem Go to Intermittent section
3	<ul style="list-style-type: none"> • Check all ECM power and ground circuits. Refer to power and ground distribution in engine electrical section. Are the power and ground circuits Ok?		Go to Step (4)	Repair the circuit as necessary. Refer to Wiring Repairs in Engine Electrical.
4	<ul style="list-style-type: none"> • Replace ECM Is the replacement complete?		Go to Step (4)	-
5	<ul style="list-style-type: none"> • Remove all test equipment except the DST. • Connect any disconnected components, fuses, etc. • Using the DST clear DTC information from the ECM. • Turn the ignition OFF and wait 30 seconds. • Start the engine and operate the vehicle to full operating temperature • Observe the MIL • Observe engine performance and driveability • After operating the engine within the test parameters of DTC-511 check for any stored codes. Does the engine operate normally with no stored codes?		System OK	Go to OBD System Check

DTC 512-Invalid Interrupt

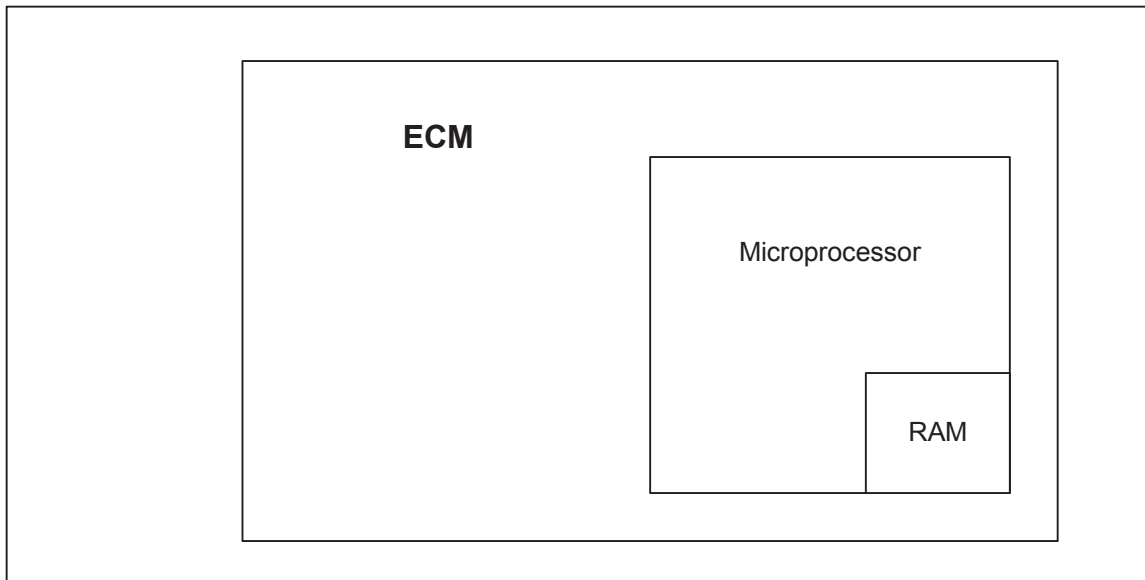

Conditions for Setting the DTC

- Engine Control Module
- Check Condition- Key on
- Fault Condition- Internal microprocessor error
- MIL- On until code is cleared by technician
- Adaptive- Disabled for the remainder of the key-on cycle
- Closed Loop- Enabled
- Power Derate (level 2 until fault is cleared manually)

Circuit Description

The ECM has checks that must be verified each time an instruction is executed. Several different things can happen within the microprocessor that will cause this fault. The ECM will reset itself in the event this fault is set, and the MIL will be on until the code is cleared. This fault should be erased after diagnosis by removing battery power. It will not self-erase.

During this active fault, Power Derate (level 2) will be enforced. When this is enforced, maximum throttle position will be 20%. This is enforced until the fault is manually cleared.

DTC 512 Invalid Interrupt

Step	Action	Value(s)	Yes	No
1	Did you perform the On-Board (OBD) System Check?	-	Go to Step (2)	Go to OBD System Check Section
2	<ul style="list-style-type: none"> • Key On, Engine Running • DST (Diagnostic Scan Tool) connected in • System Data Mode • Clear system fault code Does DTC 512 reset with the engine idling?		Go to Step (3)	Intermittent problem Go to Intermittent section
3	<ul style="list-style-type: none"> • Check all ECM power and ground circuits. Refer to power and ground distribution in engine electrical section. Are the power and ground circuits Ok?		Go to Step (4)	Repair the circuit as necessary. Refer to Wiring Repairs in Engine Electrical.
4	<ul style="list-style-type: none"> • Replace ECM Is the replacement complete?		Go to Step (4)	-
5	<ul style="list-style-type: none"> • Remove all test equipment except the DST. • Connect any disconnected components, fuses, etc. • Using the DST clear DTC information from the ECM. • Turn the ignition OFF and wait 30 seconds. • Start the engine and operate the vehicle to full operating temperature • Observe the MIL • Observe engine performance and driveability • After operating the engine within the test parameters of DTC-512 check for any stored codes. Does the engine operate normally with no stored codes?		System OK	Go to OBD System Check

DTC 513-A/D Loss

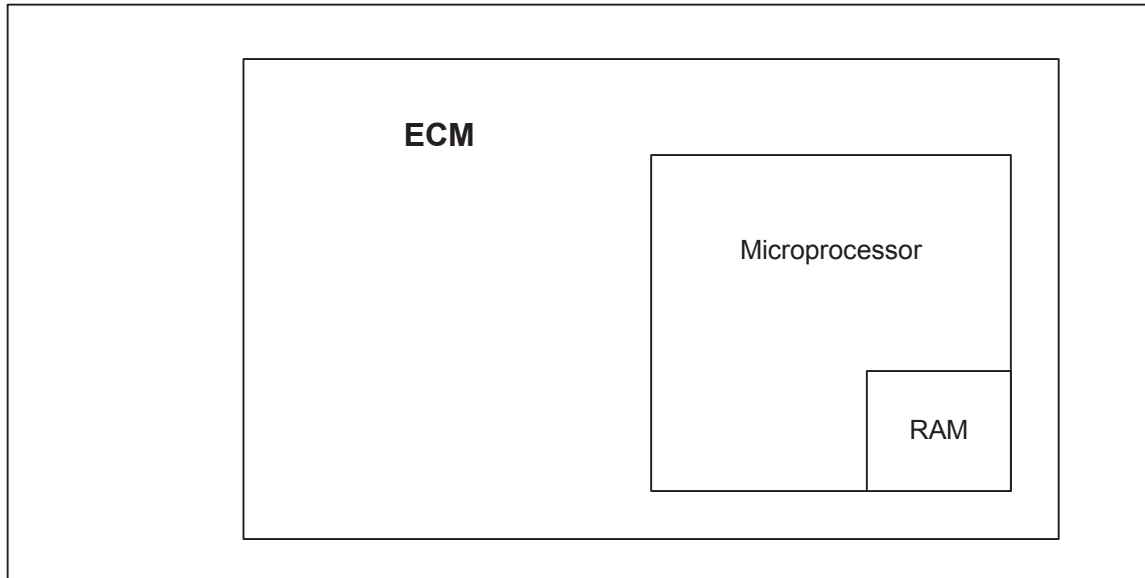

Conditions for Setting the DTC

- Engine Control Module
- Check Condition- Key on
- Fault Condition- Internal microprocessor error
- MIL- On until code is cleared by technician
- Adaptive- Disabled for the remainder of the key-on cycle
- Closed Loop- Enabled
- Power Derate (level 2 until fault is cleared manually)

Circuit Description

The ECM has checks that must be verified each time an instruction is executed. Several different things can happen within the microprocessor that will cause this fault. The ECM will reset itself in the event this fault is set, and the MIL will be on until the code is cleared. This fault should be erased after diagnosis by removing battery power. It will not self-erase.

During this active fault, Power Derate (level 2) will be enforced. When this is enforced, maximum throttle position will be 20%. This is enforced until the fault is manually cleared.

DTC 513 A/D Loss

Step	Action	Value(s)	Yes	No
1	Did you perform the On-Board (OBD) System Check?	-	Go to Step (2)	Go to OBD System Check Section
2	<ul style="list-style-type: none"> • Key On, Engine Running • DST (Diagnostic Scan Tool) connected in • System Data Mode • Clear system fault code Does DTC 513 reset with the engine idling?		Go to Step (3)	Intermittent problem Go to Intermittent section
3	<ul style="list-style-type: none"> • Check all ECM power and ground circuits. Refer to power and ground distribution in engine electrical section. Are the power and ground circuits Ok?		Go to Step (4)	Repair the circuit as necessary. Refer to Wiring Repairs in Engine Electrical.
4	<ul style="list-style-type: none"> • Replace ECM Is the replacement complete?		Go to Step (4)	-
5	<ul style="list-style-type: none"> • Remove all test equipment except the DST. • Connect any disconnected components, fuses, etc. • Using the DST clear DTC information from the ECM. • Turn the ignition OFF and wait 30 seconds. • Start the engine and operate the vehicle to full operating temperature • Observe the MIL • Observe engine performance and driveability • After operating the engine within the test parameters of DTC-513 check for any stored codes. Does the engine normally with no stored codes?		System OK	Go to OBD System Check

DTC 514-RTI 1 Loss

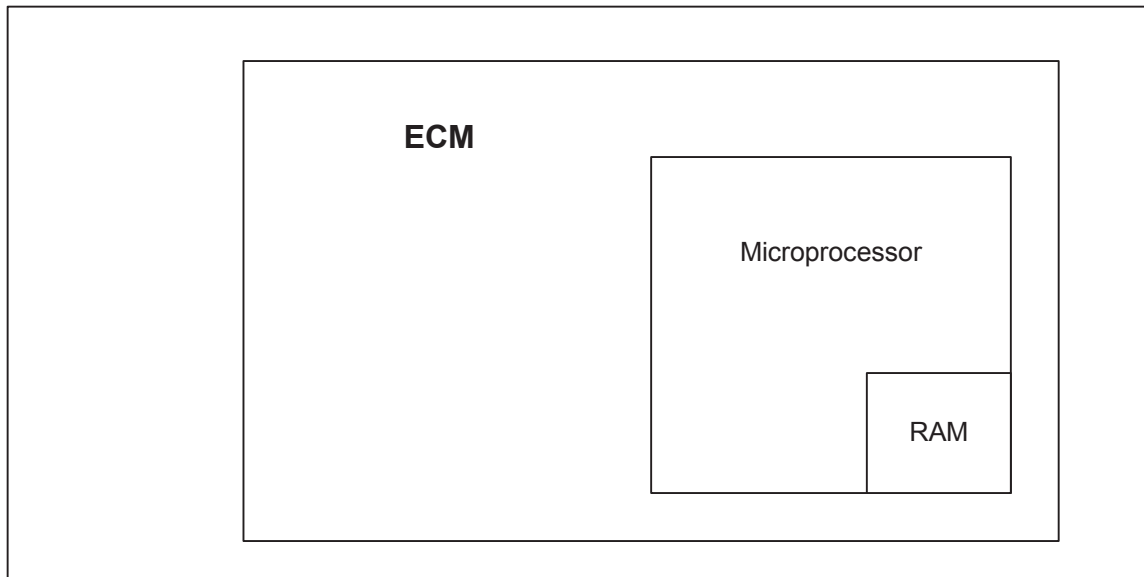

Conditions for Setting the DTC

- Engine Control Module
- Check Condition- Key on
- Fault Condition- Internal microprocessor error
- MIL- On until code is cleared by technician
- Adaptive- Disabled for the remainder of the key-on cycle
- Closed Loop- Enabled
- Power Derate (level 2 until fault is cleared manually)

Circuit Description

The ECM runs checks that must be verified each time an instruction is executed. Several different things can happen within the microprocessor that will cause this fault. The ECM will reset itself in the event this fault is set, and the MIL will be on until the code is cleared. This fault should be erased after diagnosis by removing battery power. It will not self-erase.

During this active fault, Power Derate (level 2) will be enforced. When this is enforced, maximum throttle position will be 20%. This is enforced until the fault is manually cleared.

DTC 514 RTI 1 Loss

Step	Action	Value(s)	Yes	No
1	Did you perform the On-Board (OBD) System Check?	-	Go to Step (2)	Go to OBD System Check Section
2	<ul style="list-style-type: none"> • Key On, Engine Running • DST (Diagnostic Scan Tool) connected in • System Data Mode • Clear system fault code Does DTC 514 reset with the engine idling?		Go to Step (3)	Intermittent problem Go to Intermittent section
3	<ul style="list-style-type: none"> • Check all ECM power and ground circuits. Refer to power and ground distribution in engine electrical section. Are the power and ground circuits Ok?		Go to Step (4)	Repair the circuit as necessary. Refer to Wiring Repairs in Engine Electrical.
4	<ul style="list-style-type: none"> • Replace ECM Is the replacement complete?		Go to Step (4)	-
5	<ul style="list-style-type: none"> • Remove all test equipment except the DST. • Connect any disconnected components, fuses, etc. • Using the DST clear DTC information from the ECM. • Turn the ignition OFF and wait 30 seconds. • Start the engine and operate the vehicle to full operating temperature • Observe the MIL • Observe engine performance and driveability • After operating the engine within the test parameters of DTC-514 check for any stored codes. Does the engine operate normally with no stored codes?		System OK	Go to OBD System Check

DTC 515-Flash Checksum Invalid

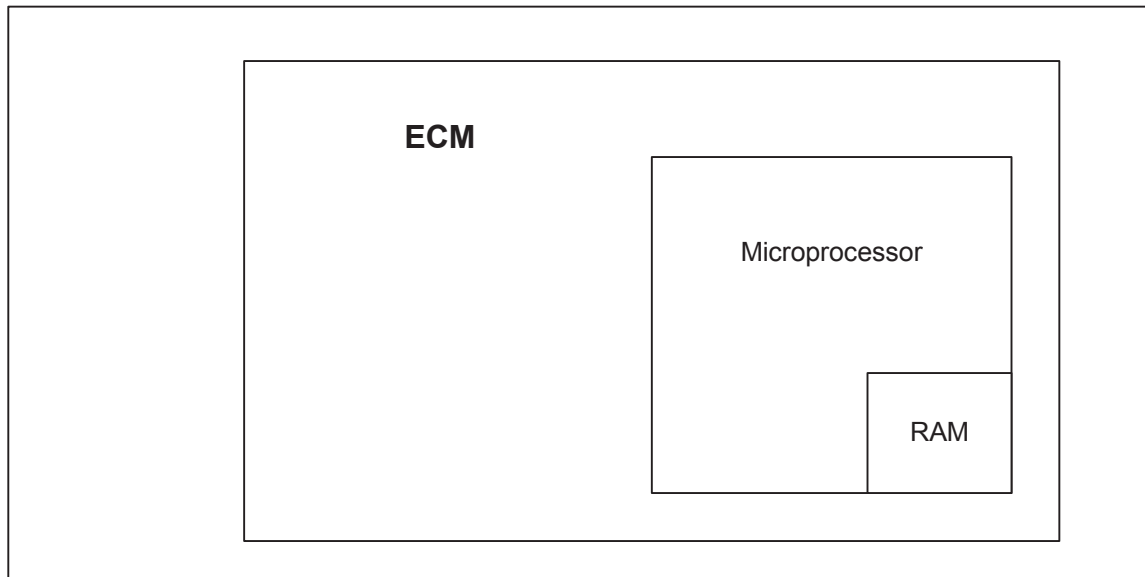

Conditions for Setting the DTC

- Engine Control Module
- Check Condition- Key on
- Fault Condition- Internal microprocessor error
- MIL- On until code is cleared by technician
- Adaptive- Disabled for the remainder of the key-on cycle
- Closed Loop- Enabled
- Power Derate (level 2 until fault is cleared manually)

Circuit Description

The ECM has checks that must be satisfied each time an instruction is executed. Several different things can happen within the microprocessor that will cause this fault. The ECM will reset itself in the event this fault is set, and the MIL will be on until the code is cleared. This fault should be erased after diagnosis by removing battery power. It will not self-erase. During this active fault, Power Derate (level 2) will be enforced. When this is enforced, maximum throttle position will be 20%. This is enforced until the fault is manually cleared.

DTC 515 Flash Checksum Invalid

Step	Action	Value(s)	Yes	No
1	Did you perform the On-Board (OBD) System Check?	-	Go to Step (2)	Go to OBD System Check Section
2	<ul style="list-style-type: none"> • Key On, Engine Running • DST (Diagnostic Scan Tool) connected in • System Data Mode • Clear system fault code Does DTC 515 reset with the engine idling?		Go to Step (3)	Intermittent problem Go to Intermittent section
3	<ul style="list-style-type: none"> • Check all ECM power and ground circuits. Refer to power and ground distribution in engine electrical section. Are the power and ground circuits Ok?		Go to Step (4)	Repair the circuit as necessary. Refer to Wiring Repairs in Engine Electrical.
4	<ul style="list-style-type: none"> • Replace ECM Is the replacement complete?		Go to Step (4)	-
5	<ul style="list-style-type: none"> • Remove all test equipment except the DST. • Connect any disconnected components, fuses, etc. • Using the DST clear DTC information from the ECM. • Turn the ignition OFF and wait 30 seconds. • Start the engine and operate the vehicle to full operating temperature • Observe the MIL • Observe engine performance and driveability • After operating the engine within the test parameters of DTC-515 check for any stored codes. Does the engine operate normally with no stored codes?		System OK	Go to OBD System Check

DTC 516-Ram Failure

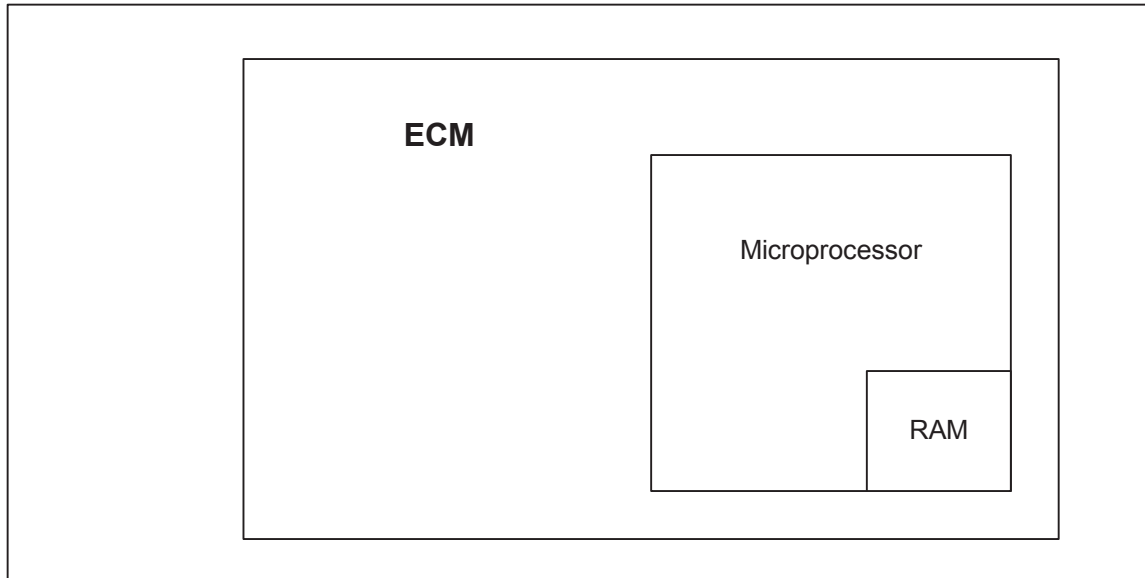

Conditions for Setting the DTC

- Random Access Memory
- Check Condition- Key-On
- Fault Condition- Internal ECM memory access failure
- MIL- On until fault is cleared
- Adaptive- Disabled for the remainder of the key-on cycle
- Closed Loop- Enabled
- Power Derate (level 2) enforced

Circuit Description

Random Access Memory is located within the microprocessor that can be read from or written to at any time. The System Fault Codes and the Adaptive Learn Table are among the data stored in RAM. This fault will set if the ECM detects a problem accessing or writing information to RAM. This fault will not self erase and must be cleared manually.

DTC 516 Ram Failure

Step	Action	Value(s)	Yes	No
1	Did you perform the On-Board (OBD) System Check?	-	Go to Step (2)	Go to OBD System Check Section
2	<ul style="list-style-type: none"> • Key On, Engine Running • DST (Diagnostic Scan Tool) connected in • System Data Mode • Clear system fault code Does DTC 516 reset with the engine idling?		Go to Step (3)	Intermittent problem Go to Intermittent section
3	<ul style="list-style-type: none"> • Check all ECM power and ground circuits. Refer to power and ground distribution in engine electrical section. Are the power and ground circuits Ok?		Go to Step (4)	Repair the circuit as necessary. Refer to Wiring Repairs in Engine Electrical.
4	<ul style="list-style-type: none"> • Replace ECM Is the replacement complete?		Go to Step (4)	-
5	<ul style="list-style-type: none"> • Remove all test equipment except the DST. • Connect any disconnected components, fuses, etc. • Using the DST clear DTC information from the ECM. • Turn the ignition OFF and wait 30 seconds. • Start the engine and operate the vehicle to full operating temperature • Observe the MIL • Observe engine performance and driveability • After operating the engine within the test parameters of DTC-516 check for any stored codes. Does the engine operate normally with no stored codes?		System OK	Go to OBD System Check

DTC 531-External 5V Ref Lower Than Expected

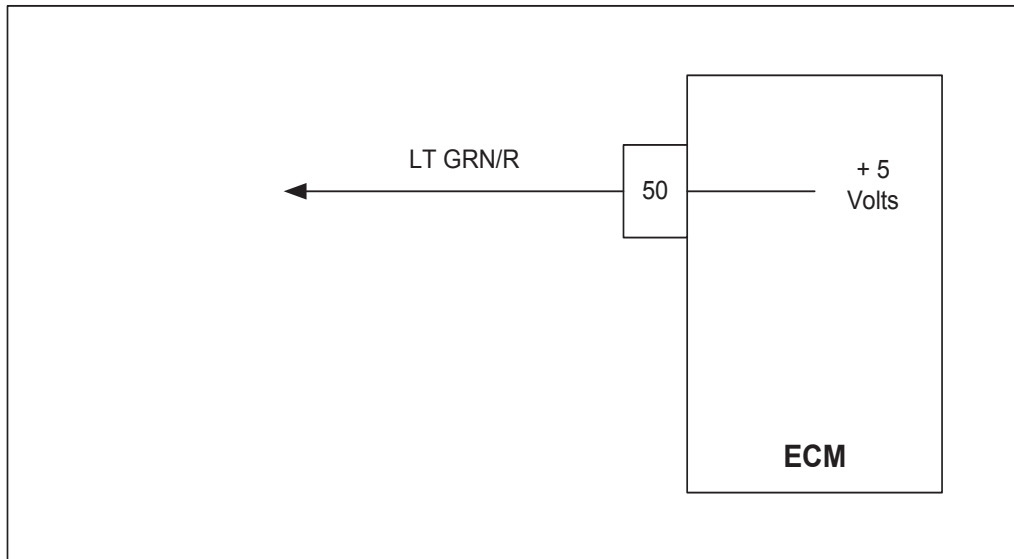

Conditions for Setting the DTC

- External 5V reference
- Check Condition-Cranking with battery voltage greater than 8 volts and engine running
- Fault Condition-5V reference voltage lower than 4.6 volts
- MIL-On during active fault and for 2 seconds after active fault
- Adaptive-Disabled during active fault
- Closed Loop-Enabled

Circuit Description

The External 5 Volt supply powers some of the sensors and other components in the system. The accuracy of the 5 Volt supply is very important to the accuracy of the sensors and therefore controlled by the ECM. The ECM monitors the 5 volt supply to determine if it is overloaded, shorted, or otherwise out of specification. This fault will set if the 5 Volt reference is below 4.6 volts.

DTC 531 External 5V Reference Lower Than Expected

Step	Action	Value(s)	Yes	No
1	Did you perform the On-Board (OBD) System Check?	-	Go to Step (2)	Go to OBD System Check Section
2	<ul style="list-style-type: none"> • Key ON, Engine Running • DST (Diagnostic Scan Tool) connected in System Fault Mode Does DST display DTC 531?		Go to Step (3)	Intermittent problem Go to Intermittent section
3	<ul style="list-style-type: none"> • Key OFF • Disconnect ECM connector • Using DVOM check for continuity between ECM 5 volt reference LT GRN/R pin 50 and engine ground Do you have continuity?		Go to Step (5)	Go to Step (4)
4	<ul style="list-style-type: none"> • Replace ECM Is the replacement complete?		Go to Step (7)	-
5	<ul style="list-style-type: none"> • While monitoring DVOM for continuity between ECM 5 volt reference and engine ground disconnect each sensor (below) one at a time to find the shorted 5 volt reference. When continuity to ground is lost the last sensor disconnected is the area of suspicion. Inspect 5volt reference supply wire leads for shorts before replacing the sensor. • IAT • ECT/CHT • TMAP • FPP • TPS 1 • TPS 2 • Crankshaft Sensor • Camshaft Sensor While disconnecting each sensor one at a time did you loose continuity?		Go to Step (6)	-
6	<ul style="list-style-type: none"> • Replace Sensor Is the replacement complete?		Go to step (7)	-

Step	Action	Value(s)	Yes	No
7	<ul style="list-style-type: none"> • Remove all test equipment except the DST. • Connect any disconnected components, fuses, etc. • Using the DST clear DTC information from the ECM. • Turn the ignition OFF and wait 30 seconds. • Start the engine and operate the vehicle to full operating temperature • Observe the MIL • Observe engine performance and driveability • After operating the engine within the test parameters of DTC-531 check for any stored codes. <p>Does the engine operate normally with no stored codes?</p>		System OK	Go to OBD System Check

DTC 532-External 5 V Ref Higher Than Expected

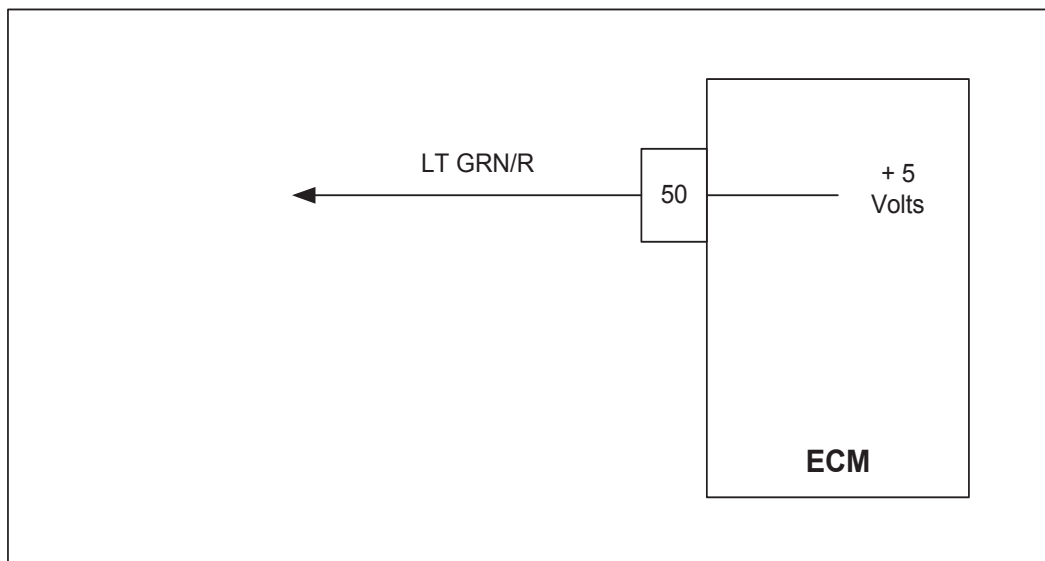

Conditions for Setting the DTC

- External 5V reference
- Check Condition-Cranking with battery voltage greater than 8 volts or engine running
- Fault Condition-5V reference voltage higher than 5.4 volts
- MIL-On during active fault and for 2 seconds after active fault
- Adaptive-Disabled during active fault
- Closed Loop-Enabled

Circuit Description

The External 5 Volt supply powers some of the sensors and other components in the system. The accuracy of the 5 Volt supply is very important to the accuracy of the sensors and therefore control by the ECM. The ECM to determine if they are overloaded, shorted, or otherwise out of specification monitors the 5 Volt supply. This fault will set if the 5 Volt reference is above 5.4 volts.

DTC 532 External 5V Reference Higher Than Expected

Step	Action	Value(s)	Yes	No
1	Did you perform the On-Board (OBD) System Check?	-	Go to Step (2)	Go to OBD System Check Section
2	<ul style="list-style-type: none"> • Key ON, Engine running • DST (Diagnostic Scan Tool) connected in System Data Mode Does DST display DTC 532?		Go to Step (3)	Intermittent problem Go to Intermittent section
3	<ul style="list-style-type: none"> • Check all ECM ground connections Refer to Engine electrical power and ground distribution. Are the ground connections Ok?		Go to Step (4)	Repair the circuit as necessary. Refer to Wiring Repairs in Engine Electrical.
4	<ul style="list-style-type: none"> • Key OFF • Disconnect ECM connector • Key ON • Using DVOM check for Voltage between ECM harness wire LT GRN/R pin 50 and engine ground Do you have voltage?		Repair the circuit as necessary. Refer to Wiring Repairs in Engine Electrical.	Go to Step (5)
5	<ul style="list-style-type: none"> • Replace ECM Is the replacement complete?		Go to Step (6)	-
6	<ul style="list-style-type: none"> • Remove all test equipment except the DST. • Connect any disconnected components, fuses, etc. • Using the DST clear DTC information from the ECM. • Turn the ignition OFF and wait 30 seconds. • Start the engine and operate the vehicle to full operating temperature • Observe the MIL • Observe engine performance and driveability • After operating the engine within the test parameters of DTC-532 check for any stored codes. Does the vehicle engine normally with no stored codes?		System OK	Go to OBD System Check

DTC 555-RTI 2 Loss

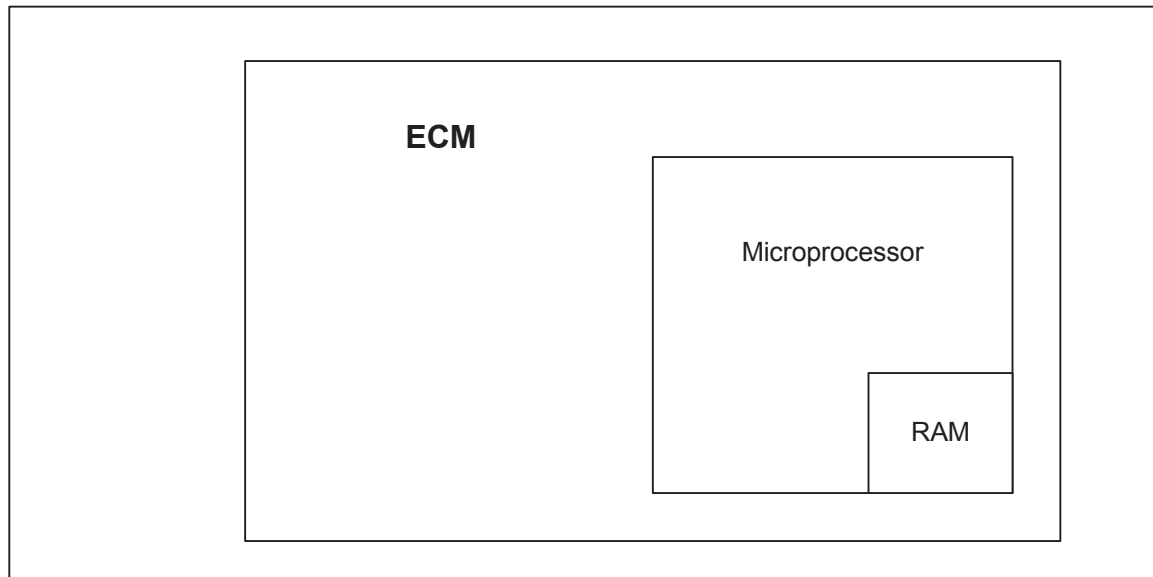

Conditions for Setting the DTC

- Engine Control Module
- Check Condition- Key on
- Fault Condition- Internal microprocessor error
- MIL- On until code is cleared by technician
- Adaptive- Disabled for the remainder of the key-on cycle
- Closed Loop- Enabled
- Power Derate (level 2 until fault is cleared manually)

Circuit Description

The ECM has checks that must be satisfied each time an instruction is executed. Several different things can happen within the microprocessor that will cause this fault. The ECM will reset itself in the event this fault is set, and the MIL will be on until the code is cleared. This fault should be erased after diagnosis by removing battery power. It will not self-erase.

During this active fault, Power Derate (level 2) will be enforced. When this is enforced, maximum throttle position will be 20%. This is enforced until the fault is manually cleared.

DTC 555 RTI 2 Loss

Step	Action	Value(s)	Yes	No
1	Did you perform the On-Board (OBD) System Check?	-	Go to Step (2)	Go to OBD System Check Section
2	<ul style="list-style-type: none"> • Key On, Engine Running • DST (Diagnostic Scan Tool) connected in • System Data Mode • Clear system fault code Does DTC 555 reset with the engine idling?		Go to Step (3)	Intermittent problem Go to Intermittent section
3	<ul style="list-style-type: none"> • Check all ECM power and ground circuits. Refer to power and ground distribution in engine electrical section. Are the power and ground circuits Ok?		Go to Step (4)	Repair the circuit as necessary. Refer to Wiring Repairs in Engine Electrical.
4	<ul style="list-style-type: none"> • Replace ECM Is the replacement complete?		Go to Step (4)	-
5	<ul style="list-style-type: none"> • Remove all test equipment except the DST. • Connect any disconnected components, fuses, etc. • Using the DST clear DTC information from the ECM. • Turn the ignition OFF and wait 30 seconds. • Start the engine and operate the vehicle to full operating temperature • Observe the MIL • Observe engine performance and driveability • After operating the engine within the test parameters of DTC-555 check for any stored codes. Does the engine operate normally with no stored codes?		System OK	Go to OBD System Check

DTC 556-RTI 3 Loss

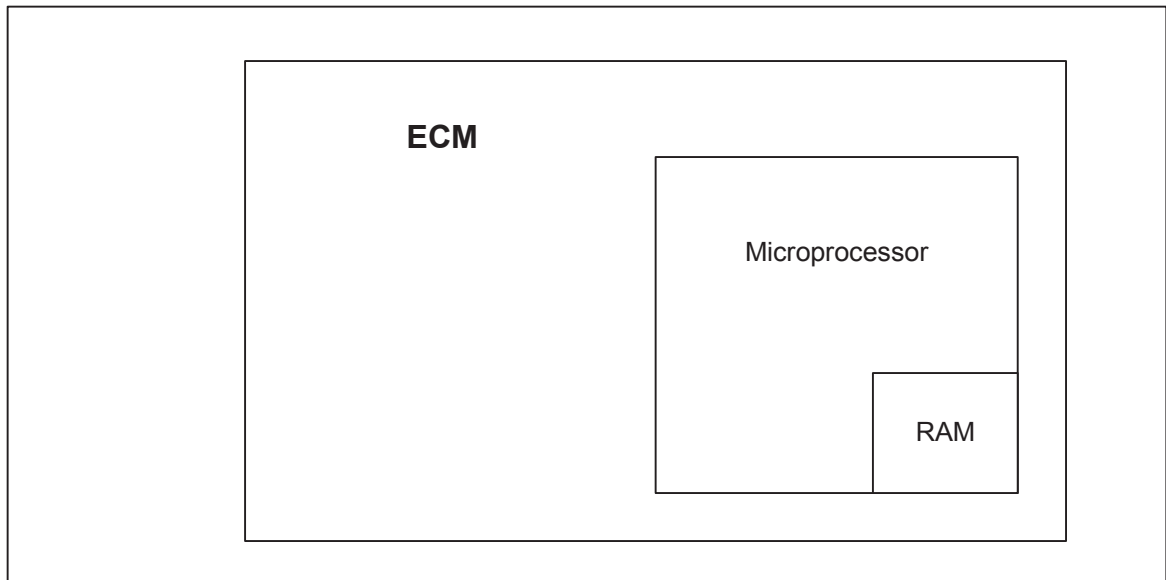

Conditions for Setting the DTC

- Engine Control Module
- Check Condition- Key on
- Fault Condition- Internal microprocessor error
- MIL- On until code is cleared by technician
- Adaptive- Disabled for the remainder of the key-on cycle
- Closed Loop- Enabled
- Power Derate (level 2 until fault is cleared manually)

Circuit Description

The ECM runs checks that must be satisfied each time an instruction is executed. Several different things can happen within the microprocessor that will cause this fault. The ECM will reset itself in the event this fault is set, and the MIL will be on until the code is cleared. This fault should be erased after diagnosis by removing battery power. It will not self-erase.

During this active fault, Power Derate (level 2) will be enforced. When this is enforced, maximum throttle position will be 20%. This is enforced until the fault is manually cleared.

DTC 556 RTI 3 Loss

Step	Action	Value(s)	Yes	No
1	Did you perform the On-Board (OBD) System Check?	-	Go to Step (2)	Go to OBD System Check Section
2	<ul style="list-style-type: none"> • Key On, Engine Running • DST (Diagnostic Scan Tool) connected in • System Data Mode • Clear system fault code Does DTC 555 reset with the engine idling?		Go to Step (3)	Intermittent problem Go to Intermittent section
3	<ul style="list-style-type: none"> • Check all ECM power and ground circuits. Refer to power and ground distribution in engine electrical section. Are the power and ground circuits Ok?		Go to Step (4)	Repair the circuit as necessary. Refer to Wiring Repairs in Engine Electrical.
4	<ul style="list-style-type: none"> • Replace ECM Is the replacement complete?		Go to Step (4)	-
5	<ul style="list-style-type: none"> • Remove all test equipment except the DST. • Connect any disconnected components, fuses, etc. • Using the DST clear DTC information from the ECM. • Turn the ignition OFF and wait 30 seconds. • Start the engine and operate the vehicle to full operating temperature • Observe the MIL • Observe engine performance and driveability • After operating the engine within the test parameters of DTC-556 check for any stored codes. Does the engine operate normally with no stored codes?		System OK	Go to OBD System Check

DTC 631-TPS 1 Signal Voltage High

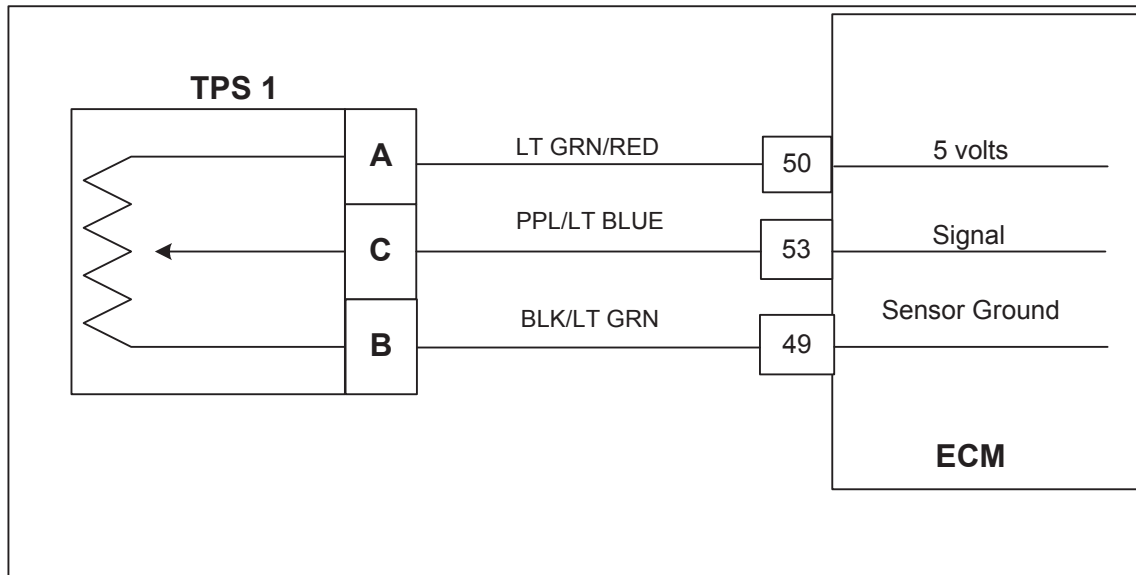

Conditions for Setting the DTC

- Throttle Position Sensor #1
- Check Condition-Cranking or Running
- Fault Condition-TPS sensor voltage exceeds 4.8
- MIL-On during active fault
- Engine Shut Down

Circuit Description

The Electronic Throttle has two counter acting Throttle Position Sensors. Two sensors are used for improved safety and redundancy. The Throttle Position sensor uses a variable resistor to determine signal voltage based on throttle plate position, and is connected to the throttle shaft. Less opening results in lower voltage, and greater opening in higher voltage. The TPS value is used by the ECM to determine if the throttle is opening as commanded.

This fault will set if voltage is above 4.8 volts at any operating condition while the engine is cranking or running. The engine will not start or run during this active fault.

DTC 631 TPS 1 Signal Voltage High

Step	Action	Value(s)	Yes	No
1	Did you perform the On-Board (OBD) System Check?	-	<i>Go to Step (2)</i>	<i>Go to OBD System Check Section</i>
2	<ul style="list-style-type: none"> • Key ON, Engine OFF DST (Diagnostic Scan Tool) connected Does the DST display TPS 1 voltage of 4.8 volts or greater with the throttle closed		<i>Go to Step (4)</i>	<i>Go to Step (3)</i>
3	<ul style="list-style-type: none"> • Slowly depress Foot Pedal while observing TPS 1 voltage Does TPS 1 voltage ever exceed 4.8 volts?		<i>Go to Step (4)</i>	<i>Intermittent problem Go to Intermittent section</i>
4	<ul style="list-style-type: none"> • Key OFF • Disconnect TPS 1 electrical connector • Key ON Does DST display TPS 1 voltage less than 0.2 volts?		<i>Go to Step (7)</i>	<i>Go to Step (5)</i>
5	<ul style="list-style-type: none"> • Key OFF • Disconnect ECM wire harness connector • Key ON • Using a DVOM check for voltage between TPS 1 signal at the ECM connector pin 53 and engine ground Do you have voltage?		Repair the circuit as necessary. Refer to Wiring Repairs in Engine Electrical.	<i>Go to Step (6)</i>
6	<ul style="list-style-type: none"> • Replace ECM Is the replacement complete?		<i>Go to Step (11)</i>	-
7	<ul style="list-style-type: none"> • Back probe sensor ground circuit at the ECM side of the wire harness pin 49 with a test light connected to battery voltage Does the test light come on?		<i>Go to Step (8)</i>	<i>Go to Step (10)</i>
8	<ul style="list-style-type: none"> • Inspect the TPS 1 electrical connector terminals for damage, corrosion or contamination Did you find a problem?		Repair the circuit as necessary. Refer to Wiring Repairs in Engine Electrical.	<i>Go to Step (9)</i>
9	<ul style="list-style-type: none"> • Replace TPS 1 sensor Is the replacement complete?		<i>Go to Step (11)</i>	-
10	<ul style="list-style-type: none"> • Key OFF • Disconnect ECM connector • Using a DVOM check for continuity between the TPS 1 connector sensor ground pin B and ECM connector TPS 1 sensor ground pin 49 Do have continuity between them?		<i>Go to Step (6)</i>	Repair the circuit as necessary. Refer to Wiring Repairs in Engine Electrical.

Step	Action	Value(s)	Yes	No
11	<ul style="list-style-type: none">• Remove all test equipment except the DST.• Connect any disconnected components, fuses, etc.• Using the DST clear DTC information from the ECM.• Turn the ignition OFF and wait 30 seconds.• Start the engine and operate the vehicle to full operating temperature• Observe the MIL• Observe engine performance and driveability• After operating the engine within the test parameters of DTC-631 check for any stored codes. <p>Does the engine operate normally with no stored codes?</p>		System OK	Go to <i>OBD System Check</i>

DTC 632-TPS 1 Signal Voltage Low

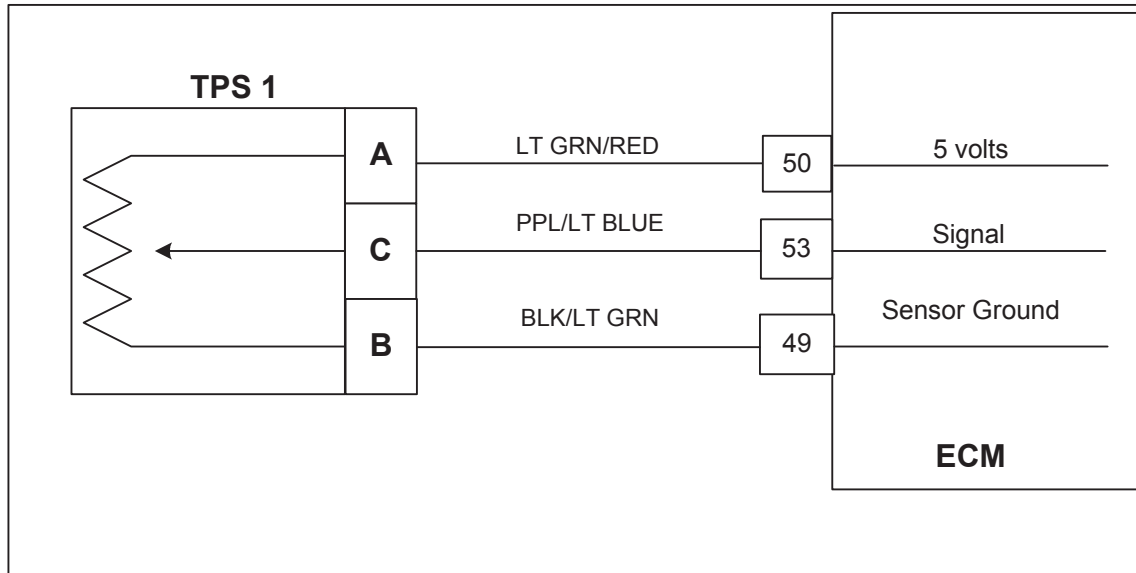

Conditions for Setting the DTC

- Throttle Position Sensor #1
- Check Condition-Cranking or Running
- Fault Condition-TPS sensor voltage less than 0.2
- MIL-On during active fault
- Engine Shut Down

Circuit Description

The Electronic Throttle has two counter acting Throttle Position Sensors. Two sensors are used for improved safety and redundancy.

The Throttle Position sensor uses a variable resistor to determine signal voltage based on throttle plate position, and is located within the throttle. Less opening results in lower voltage, and greater opening in higher voltage. The TPS value is used by the ECM to determine if the throttle is opening as commanded.

This fault will set if voltage is less than 0.2 volts at any operating condition while the engine is cranking or running. The engine will not start or run during this active fault.

DTC 632 TPS 1 Signal Voltage Low

Step	Action	Value(s)	Yes	No
1	Did you perform the On-Board (OBD) System Check?	-	Go to Step (2)	Go to OBD System Check Section
2	<ul style="list-style-type: none"> Key ON, Engine OFF DST (Diagnostic Scan Tool) connected in DBW (Drive by Wire) throttle test mode Does the DST display TPS 1 voltage of 0.2 volts or less with the throttle closed?		Go to Step (4)	Go to Step (3)
3	<ul style="list-style-type: none"> Slowly depress Foot Pedal while observing TPS 1 voltage Does TPS 1 voltage ever fall below 0.2 volts?		Go to Step (4)	Intermittent problem Go to Intermittent section
4	<ul style="list-style-type: none"> Key OFF Disconnect the TPS 1 electrical connector Jumper the 5 volt reference circuit pin A and TPS 1 signal circuit pin C together at the throttle connector Key ON Does DST display TPS 1 voltage of 4.0 volts or greater?		Go to Step (7)	Go to Step (5)
5	<ul style="list-style-type: none"> Key OFF Disconnect ECM wire harness connector Using a DVOM check continuity between TPS 1 connector signal pin C and ECM connector TPS 1 signal pin 53 Do have continuity between them?		Go to Step (6)	Repair the circuit as necessary. Refer to Wiring Repairs in Engine Electrical.
6	<ul style="list-style-type: none"> Replace ECM Is the replacement complete?		Go to Step (9)	-
7	<ul style="list-style-type: none"> Inspect the throttle wire harness connector terminals for damage, corrosion or contamination Did you find a problem?		Repair the circuit as necessary. Refer to Wiring Repairs in Engine Electrical.	Go to Step (8)
8	<ul style="list-style-type: none"> Replace the TPS 1 Is the replacement complete?		Go to Step (9)	-

Step	Action	Value(s)	Yes	No
9	<ul style="list-style-type: none"> • Remove all test equipment except the DST. • Connect any disconnected components, fuses, etc. • Using the DST clear DTC information from the ECM. • Turn the ignition OFF and wait 30 seconds. • Start the engine and operate the vehicle to full operating temperature • Observe the MIL • Observe engine performance and driveability • After operating the engine within the test parameters of DTC-632 check for any stored codes. <p>Does the engine operate normally with no stored codes?</p>		System OK	Go to <i>OBD System Check</i>

DTC 633-TPS 2 Signal Voltage High

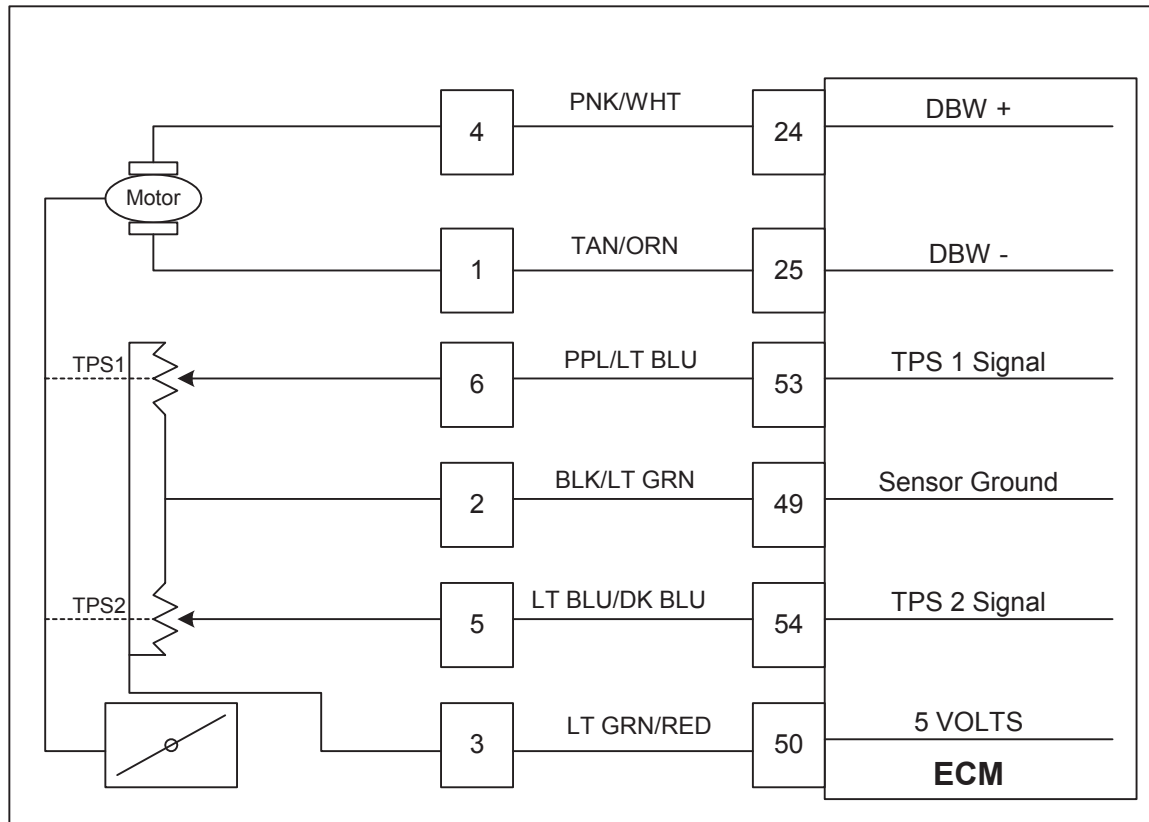

Conditions for Setting the DTC

- Throttle Position Sensor #2
- Check Condition-Cranking or Running
- Fault Condition-TPS 2 sensor exceeds 4.8 volts
- MIL-On during active fault
- Engine Shut Down

Circuit Description

The Electronic Throttle has two counter acting Throttle position Sensors. Two sensors are used for improved safety and redundancy. The Throttle Position sensor (TPS2) uses a variable resistor to determine signal voltage based on throttle plate position, and is located within the throttle. Less opening results in higher voltage and greater opening in lower voltage. The TPS value is used by the ECM to determine if the throttle is opening as commanded. This fault will set if voltage is above 4.8 volts at any operating condition while the engine is cranking or running. The engine will not start or run during this active fault.

DTC 633 TPS 2 Signal Voltage High

Step	Action	Value(s)	Yes	No
1	Did you perform the On-Board (OBD) System Check?	-	<i>Go to Step (2)</i>	<i>Go to OBD System Check Section</i>
2	<ul style="list-style-type: none"> • Key ON, Engine OFF • DST (Diagnostic Scan Tool) connected in DBW (Drive by Wire) throttle test mode Does the DST display TPS 2 voltage of 4.8 volts or greater with the throttle closed?		<i>Go to Step (4)</i>	<i>Go to Step (3)</i>
3	<ul style="list-style-type: none"> • Slowly depress Foot Pedal while observing TPS 2 voltage Does TPS 2 voltage ever exceed 4.8 volts?		<i>Go to Step (4)</i>	<i>Intermittent problem Go to Intermittent section</i>
4	<ul style="list-style-type: none"> • Key OFF • Disconnect electronic throttle connector • Key ON Does DST display TPS 2 voltage less than 0.2 volts?		<i>Go to Step (7)</i>	<i>Go to Step (5)</i>
5	<ul style="list-style-type: none"> • Key OFF • Disconnect ECM wire harness connector C001 • Key ON • Using a DVOM check for voltage between electronic throttle connector TPS 2 signal pin 5 and engine ground Do you have voltage?		Repair the circuit as necessary. Refer to Wiring Repairs in Engine Electrical.	<i>Go to Step (6)</i>
6	<ul style="list-style-type: none"> • Replace ECM Is the replacement complete?		<i>Go to Step (11)</i>	-
7	<ul style="list-style-type: none"> • Back probe sensor ground circuit at the ECM side of the wire harness pin 49 with a test light connected to battery voltage Does the test light come on?		<i>Go to Step (8)</i>	<i>Go to Step (10)</i>
8	<ul style="list-style-type: none"> • Inspect the electronic throttle wire harness connector and terminals for damage, corrosion or contamination Did you find a problem?		Repair the circuit as necessary. Refer to Wiring Repairs in Engine Electrical.	<i>Go to Step (9)</i>
9	<ul style="list-style-type: none"> • Replace electronic throttle Is the replacement complete?		<i>Go to Step (11)</i>	-
10	<ul style="list-style-type: none"> • Key OFF • Disconnect ECM connector • Using a DVOM check for continuity between throttle connector sensor ground pin 2 and ECM connector sensor ground pin 49 Do have continuity between them?		<i>Go to Step (6)</i>	Repair the circuit as necessary. Refer to Wiring Repairs in Engine Electrical.

Step	Action	Value(s)	Yes	No
11	<ul style="list-style-type: none"> • Remove all test equipment except the DST. • Connect any disconnected components, fuses, etc. • Using the DST clear DTC information from the ECM. • Turn the ignition OFF and wait 30 seconds. • Start the engine and operate the vehicle to full operating temperature • Observe the MIL • Observe engine performance and driveability • After operating the engine within the test parameters of DTC-633 check for any stored codes. <p>Does the engine operate normally with no stored codes?</p>		System OK	Go to OBD System Check

DTC 634-TPS 2 Signal Voltage Low

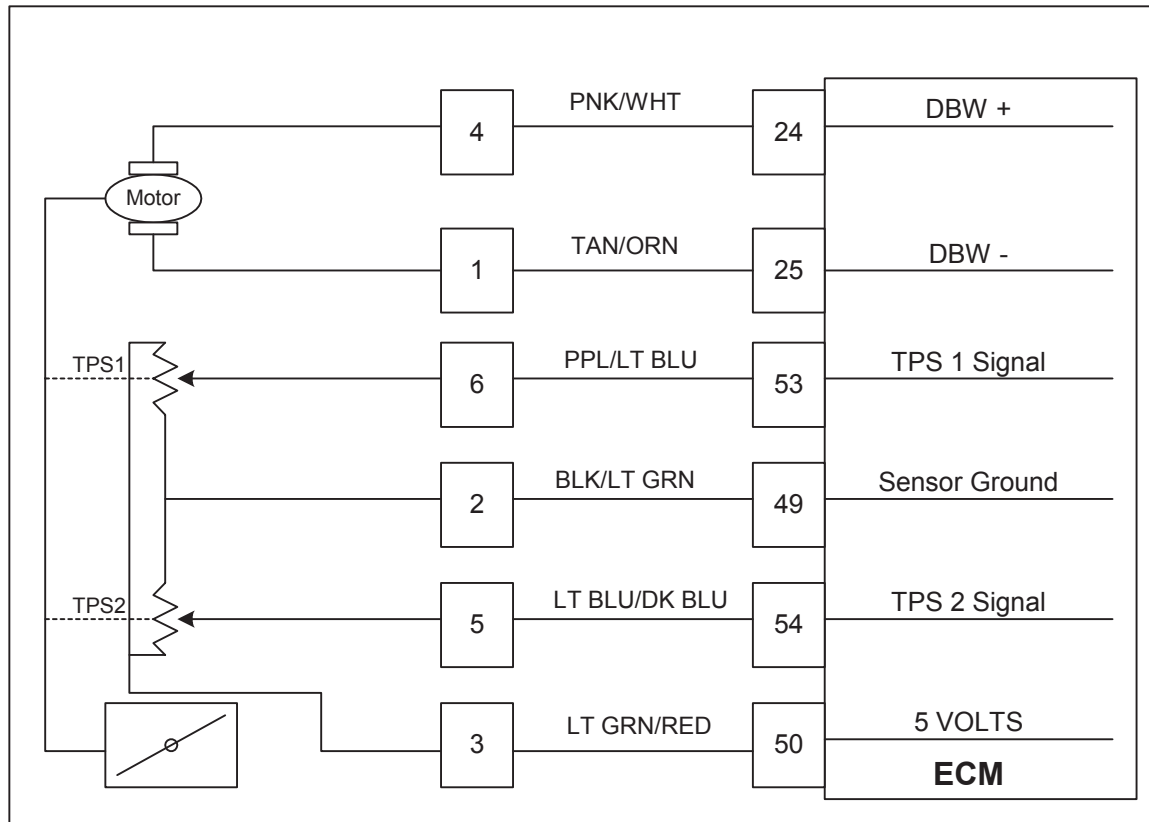

Conditions for Setting the DTC

- Throttle Position Sensor #2
- Check Condition-Cranking or Running
- Fault Condition-TPS 2 sensor voltage less than 0.2
- MIL-On during active fault
- Engine Shut Down

Circuit Description

The Electronic Throttle has two counter acting Throttle Position sensors. Two sensors are used for improved safety and redundancy. The Throttle Position Sensor (TPS2) uses a variable resistor to determine signal voltage based on throttle plate position, and is located within the throttle. Less opening results in higher voltage and greater opening in lower voltage. The TPS value is used by the ECM to determine if the throttle is opening as commanded. This fault will set if voltage is below 0.2 volts at any operating condition while the engine is cranking or running. The engine will not start or run during this active fault.

DTC 634 TPS 2 Signal Voltage Low

Step	Action	Value(s)	Yes	No
1	Did you perform the On-Board (OBD) System Check?	-	Go to Step (2)	Go to OBD System Check Section
2	<ul style="list-style-type: none"> Key ON, Engine OFF DST (Diagnostic Scan Tool) connected in DBW (Drive by Wire) throttle test mode Does the DST display TPS 2 voltage of 0.2 volts or less with the throttle closed?		Go to Step (4)	Go to Step (3)
3	<ul style="list-style-type: none"> Slowly depress Foot Pedal while observing TPS 2 voltage Does TPS 2 voltage ever fall below 0.2 volts?		Go to Step (4)	Intermittent problem Go to Intermittent section
4	<ul style="list-style-type: none"> Key OFF Disconnect electronic throttle connector Jumper the 5 volt reference circuit pin 3 and TPS 2 signal pin 5 together at the throttle connector Key ON Does DST display TPS 2 voltage of 4.0 volts or greater?		Go to Step (7)	Go to Step (5)
5	<ul style="list-style-type: none"> Key OFF Disconnect ECM wire harness connector Using a DVOM check continuity between electronic throttle TPS 2 signal pin 5 and ECM connector TPS 2 signal pin 54 Do have continuity between them?		Go to Step (6)	Repair the circuit as necessary. Refer to Wiring Repairs in Engine Electrical.
6	<ul style="list-style-type: none"> Replace ECM Is the replacement complete?		Go to Step (9)	-
7	<ul style="list-style-type: none"> Inspect the electronic throttle wire harness connector and terminals for damage, corrosion or contamination Did you find a problem?		Repair the circuit as necessary. Refer to Wiring Repairs in Engine Electrical.	Go to Step (8)
8	<ul style="list-style-type: none"> Replace throttle Is the replacement complete?		Go to Step (9)	-

Step	Action	Value(s)	Yes	No
9	<ul style="list-style-type: none"> • Remove all test equipment except the DST. • Connect any disconnected components, fuses, etc. • Using the DST clear DTC information from the ECM. • Turn the ignition OFF and wait 30 seconds. • Start the engine and operate the vehicle to full operating temperature • Observe the MIL • Observe engine performance and driveability • After operating the engine within the test parameters of DTC-634 check for any stored codes. <p>Does the engine operate normally with no stored codes?</p>		System OK	Go to <i>OBD System Check</i>

DTC 635-TPS1 Higher Than TPS 2

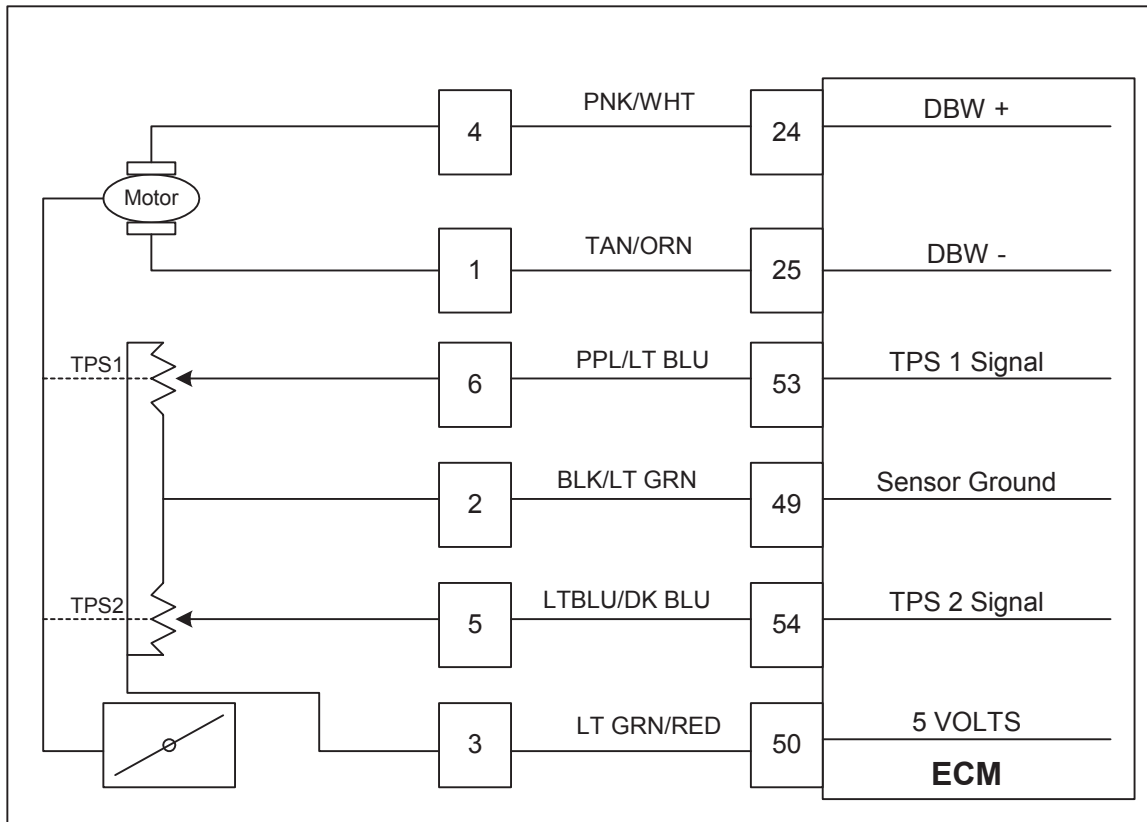

Conditions for Setting the DTC

- Throttle Position Sensor 1 & 2
- Check Condition-Key On
- Fault Condition-TPS1 higher than TPS2 (20% difference or more)
- MIL-On for remainder of key on cycle
- Adaptive-Enabled
- Closed Loop-Enabled
- Engine Shut Down

Circuit Description

There are 2 Throttle Position Sensors located within the throttle which use variable resistors to determine signal voltage based on throttle plate position. TPS1 will read low voltage when closed and TPS2 will read high voltage when closed. The TPS1 and TPS2 percentages are calculated from these voltages. Although the voltages are different, the calculated values for the throttle position percentages should be very close to the same. The TPS values are used by the ECM to determine if the throttle is opening as commanded. This fault will set if TPS1 is 20% (or more) higher than TPS2. At this point the throttle is considered to be out of specification, or there is a problem with the TPS signal circuit. During this active fault, the MIL light will be on and the engine will shut down.

DTC 634 TPS 2 Signal Voltage Low

Step	Action	Value(s)	Yes	No
1	Did you perform the On-Board (OBD) System Check?	-	Go to Step (2)	Go to OBD System Check Section
2	<ul style="list-style-type: none"> Key ON, Engine OFF DST (Diagnostic Scan Tool) connected in DBW (Drive by Wire) throttle test mode Does the DST display TPS 2 voltage of 0.2 volts or less with the throttle closed?		Go to Step (4)	Go to Step (3)
3	<ul style="list-style-type: none"> Slowly depress Foot Pedal while observing TPS 2 voltage Does TPS 2 voltage ever fall below 0.2 volts?		Go to Step (4)	Intermittent problem Go to Intermittent section
4	<ul style="list-style-type: none"> Key OFF Disconnect electronic throttle connector Jumper the 5 volt reference circuit pin 3 and TPS 2 signal pin 5 together at the throttle connector Key ON Does DST display TPS 2 voltage of 4.0 volts or greater?		Go to Step (7)	Go to Step (5)
5	<ul style="list-style-type: none"> Key OFF Disconnect ECM wire harness connector Using a DVOM check continuity between electronic throttle TPS 2 signal pin 5 and ECM connector TPS 2 signal pin 54 Do have continuity between them?		Go to Step (6)	Repair the circuit as necessary. Refer to Wiring Repairs in Engine Electrical.
6	<ul style="list-style-type: none"> Replace ECM Is the replacement complete?		Go to Step (9)	-
7	<ul style="list-style-type: none"> Inspect the electronic throttle wire harness connector and terminals for damage, corrosion or contamination Did you find a problem?		Repair the circuit as necessary. Refer to Wiring Repairs in Engine Electrical.	Go to Step (8)
8	<ul style="list-style-type: none"> Replace throttle Is the replacement complete?		Go to Step (9)	-

Step	Action	Value(s)	Yes	No
9	<ul style="list-style-type: none"> • Remove all test equipment except the DST. • Connect any disconnected components, fuses, etc. • Using the DST clear DTC information from the ECM. • Turn the ignition OFF and wait 30 seconds. • Start the engine and operate the vehicle to full operating temperature • Observe the MIL • Observe engine performance and driveability • After operating the engine within the test parameters of DTC-634 check for any stored codes. <p>Does the engine operate normally with no stored codes?</p>		System OK	Go to <i>OBD System Check</i>

DTC 636-TPS1 Lower Than TPS2

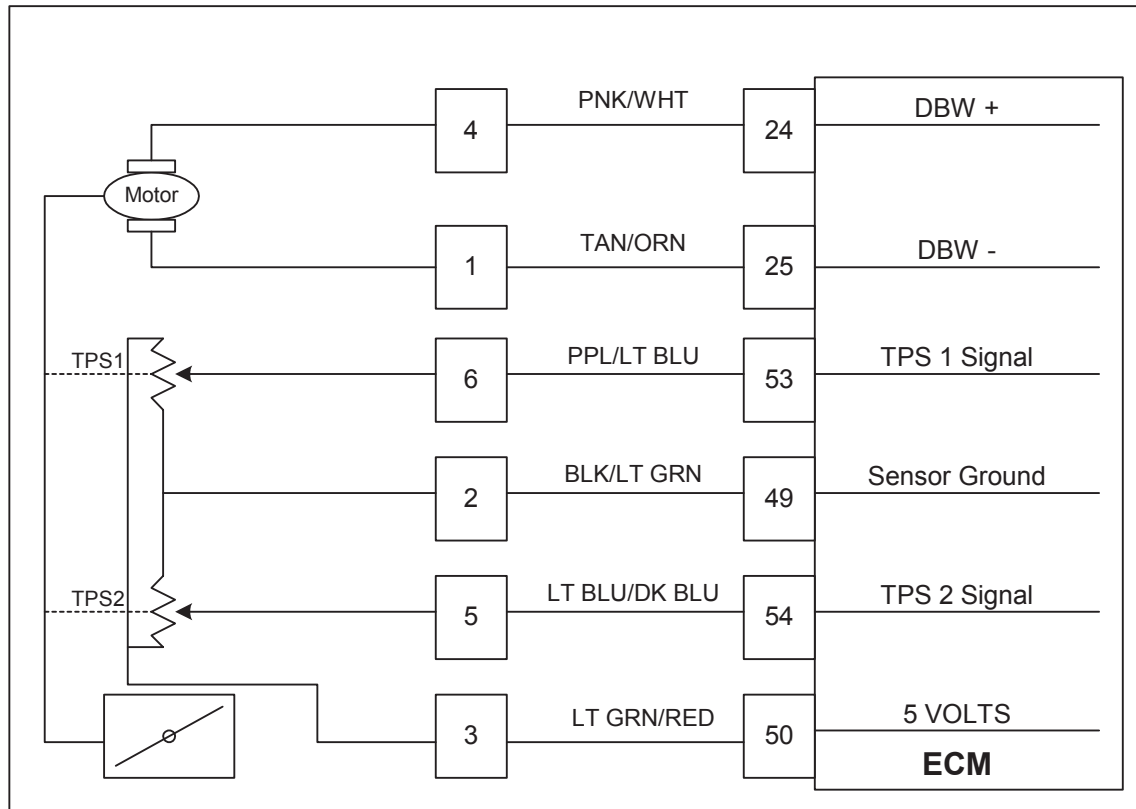

Conditions for Setting the DTC

- Throttle Position Sensor 1 & 2
- Check Condition-Key On
- Fault Condition-TPS1 lower than TPS2 (20% difference or more)
- MIL-On for remainder of key on cycle
- Adaptive-Enabled
- Closed Loop-Enabled
- Engine Shut Down

Circuit description

There are 2 Throttle Position Sensors located within the throttle which use variable resistors to determine signal voltage based on throttle plate position. TPS1 will read low voltage when closed and TPS2 will read high voltage when closed. The TPS1 and TPS2 percentages are calculated from these voltages. Although the voltages are different, the calculated values for the throttle position percentages should be very close to the same. The TPS values are used by the ECM to determine if the throttle is opening as commanded.

This fault will set if TPS1 is 20% (or more) lower than TPS2. At this point the throttle is considered to be out of specification, or there is a problem with the TPS signal circuit. During this active fault, the MIL light will be on and the engine will shut down.

DTC 636 TPS 1 Lower Than TPS 2

Step	Action	Value(s)	Yes	No
1	Did you perform the On-Board (OBD) System Check?	-	Go to Step (2)	Go to OBD System Check Section
2	<ul style="list-style-type: none"> Key ON, Engine OFF DST (Diagnostic Scan Tool) connected in System Data Mode Does the DST display more than a 20% difference between TPS 1 and TPS 2?		Go to Step (3)	Intermittent problem Go to Intermittent section
3	<ul style="list-style-type: none"> Key OFF Disconnect wiring harness connector from the electronic throttle Key ON Change DST mode to DBW (drive by wire) test mode Is the voltage for TPS 1 and TPS 2 less than 0.1 volts?		Go to Step (5)	Go to Step (4)
4	<ul style="list-style-type: none"> Key OFF Disconnect ECM wiring harness connector C001 Key ON Using a DVOM check for voltage at the ECM connector between TPS 1 signal pin 53 or TPS 2 signal pin 54 (the one that is over 0.1 volts) and engine ground Do you have voltage?		Repair the TPS 1 or TPS 2 circuit as necessary. Refer to Wiring Repairs in Engine Electrical.	Go to Step (13)
5	<ul style="list-style-type: none"> Jumper TPS 1 signal pin 6 and TPS 2 signal pin 5 to the 5 volt reference at the throttle connector pin 3 Does DST display TPS 1 and TPS 2 voltage over 4.95 volts		Go to Step (6)	Go to Step (8)
6	<ul style="list-style-type: none"> Inspect wire terminals at throttle connector for damage corrosion or contamination Any problems found?		Repair the circuit as necessary. Refer to Wiring Repairs in Engine Electrical.	Go to Step (7)
7	<ul style="list-style-type: none"> Replace Throttle Is the replacement complete?		Go to Step (14)	-
8	<ul style="list-style-type: none"> Key OFF Disconnect ECM wire harness connector C001 from ECM Using a DVOM check for continuity between throttle connector TPS 1 signal pin 6 and ECM connector TPS 1 signal pin 53 Do you have continuity between them?		Go to Step (9)	Repair the circuit as necessary. Refer to Wiring Repairs in Engine Electrical.
9	<ul style="list-style-type: none"> Using a DVOM check for continuity between throttle connector TPS 2 signal pin 5 and ECM connector TPS 2 signal pin 54 Do you have continuity between them?		Go to Step (10)	Repair the circuit as necessary. Refer to Wiring Repairs in Engine Electrical.

Step	Action	Value(s)	Yes	No
10	<ul style="list-style-type: none"> Using a DVOM check for continuity between throttle connector TPS 1 signal pin 6 and engine ground Do you have continuity?		Repair the circuit as necessary. Refer to Wiring Repairs in Engine Electrical.	Go to Step (11)
11	<ul style="list-style-type: none"> Using a DVOM check for continuity between throttle connector TPS 2 signal pin 5 and engine ground Do you have continuity?		Repair the circuit as necessary. Refer to Wiring Repairs in Engine Electrical.	Go to Step (12)
12	<ul style="list-style-type: none"> Inspect ECM connector terminals for damage corrosion or contamination. Any problems found?		Repair the circuit as necessary. Refer to Wiring Repairs in Engine Electrical.	Go to Step (13)
13	<ul style="list-style-type: none"> Replace ECM Is the replacement complete?		Go to Step (14)	-
14	<ul style="list-style-type: none"> Remove all test equipment except the DST. Connect any disconnected components, fuses, etc. Using the DST clear DTC information from the ECM. Turn the ignition OFF and wait 30 seconds. Start the engine and operate the vehicle to full operating temperature Observe the MIL Observe engine performance and driveability After operating the engine within the test parameters of DTC-636 check for any stored codes. Does the engine operate normally with no stored codes?		System OK	Go to OBD System Check

DTC 637-Throttle Unable To Open

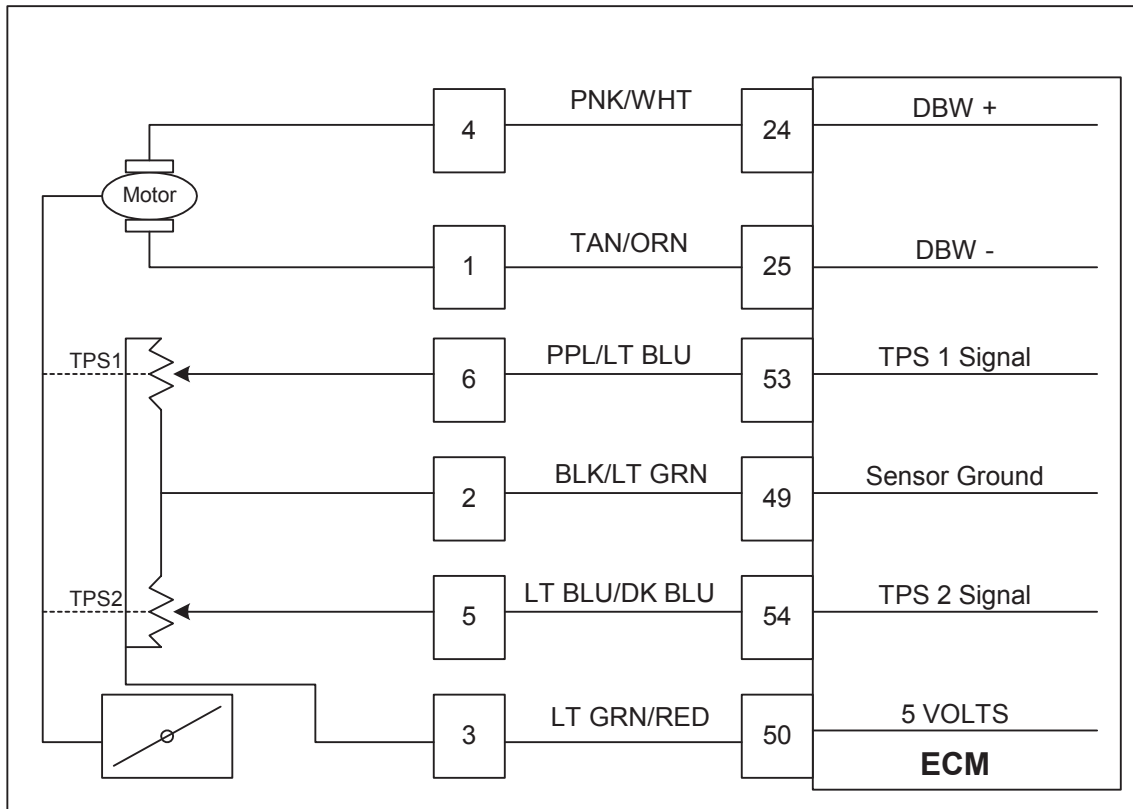

Conditions for Setting the DTC

- Throttle Position Sensor
- Check Condition-Cranking or Running
- Fault Condition-Throttle command is 20% more than actual throttle position
- MIL-On during active fault
- Adaptive-Enabled
- Closed Loop-Enabled
- Engine Shut Down

Circuit Description

There are 2 Throttle Position Sensors located within the throttle which use variable resistors to determine signal voltage based on throttle plate position. TPS1 will read low voltage when closed and TPS2 will read high voltage when closed. The TPS1 and TPS2 percentages are calculated from these voltages. Although the voltages are different, the calculated values for the throttle position percentages should be very close to the same. The TPS values are used by the ECM to determine if the throttle is opening as commanded.

This fault will set if the throttle command is 20% or more than the actual throttle position. During this active fault the MIL light will be on and the engine will shut down.

DTC 637 Throttle Unable to Open

Step	Action	Value(s)	Yes	No
1	Did you perform the On-Board (OBD) System Check?	-	Go to Step (2)	Go to OBD System Check Section
2	<ul style="list-style-type: none"> • Key ON, Engine OFF • DST (Diagnostic Scan Tool) connected in DBW (Drive By Wire) test mode • Depress Foot Pedal until the Throttle Command is 63%-68% Is the TPS voltage less than 2.0 volts?		Go to Step (3)	Intermittent problem Go to Intermittent section
3	<ul style="list-style-type: none"> • Key OFF • Disconnect wire harness connector from throttle • Probe TPS 1 signal circuit with test light connected to battery voltage • Key ON Is TPS voltage 4.0 volts or greater?		Go to Step (4)	Go to Step (8)
4	<ul style="list-style-type: none"> • Check throttle bore for foreign object Did you find a problem?		Go to Step (5)	Go to step (6)
5	<ul style="list-style-type: none"> • Remove the foreign object Has the object been removed?		Go to Step (11)	-
6	<ul style="list-style-type: none"> • Check throttle connector terminals for damage corrosion or contamination Did you find a problem?		Repair the circuit as necessary. Refer to Wiring Repairs in Engine Electrical.	Go to Step (7)
7	<ul style="list-style-type: none"> • Replace throttle Is the replacement complete?		Go to Step (11)	-
8	<ul style="list-style-type: none"> • Key OFF • Disconnect ECM wire harness connector • Using a DVOM check for continuity between throttle connector TPS 1 signal terminal and ECM TPS 1 signal terminal Do you have continuity between them?		Go to Step (9)	Repair the circuit as necessary. Refer to Wiring Repairs in Engine Electrical.
9	<ul style="list-style-type: none"> • Using a DVOM check for continuity between throttle connector TPS 1 signal and engine ground Do you have continuity between them?		Repair the circuit as necessary. Refer to Wiring Repairs in Engine Electrical.	Go to Step (10)
10	<ul style="list-style-type: none"> • Replace ECM Is the replacement complete?		Go to step (11)	-

Step	Action	Value(s)	Yes	No
11	<ul style="list-style-type: none"> • Remove all test equipment except the DST. • Connect any disconnected components, fuses, etc. • Using the DST clear DTC information from the ECM. • Turn the ignition OFF and wait 30 seconds. • Start the engine and operate the vehicle to full operating temperature • Observe the MIL • Observe engine performance and driveability • After operating the engine within the test parameters of DTC-637 check for any stored codes. <p>Does the engine operate normally with no stored codes?</p>		System OK	Go to OBD System Check

DTC 638-Throttle Unable To Close

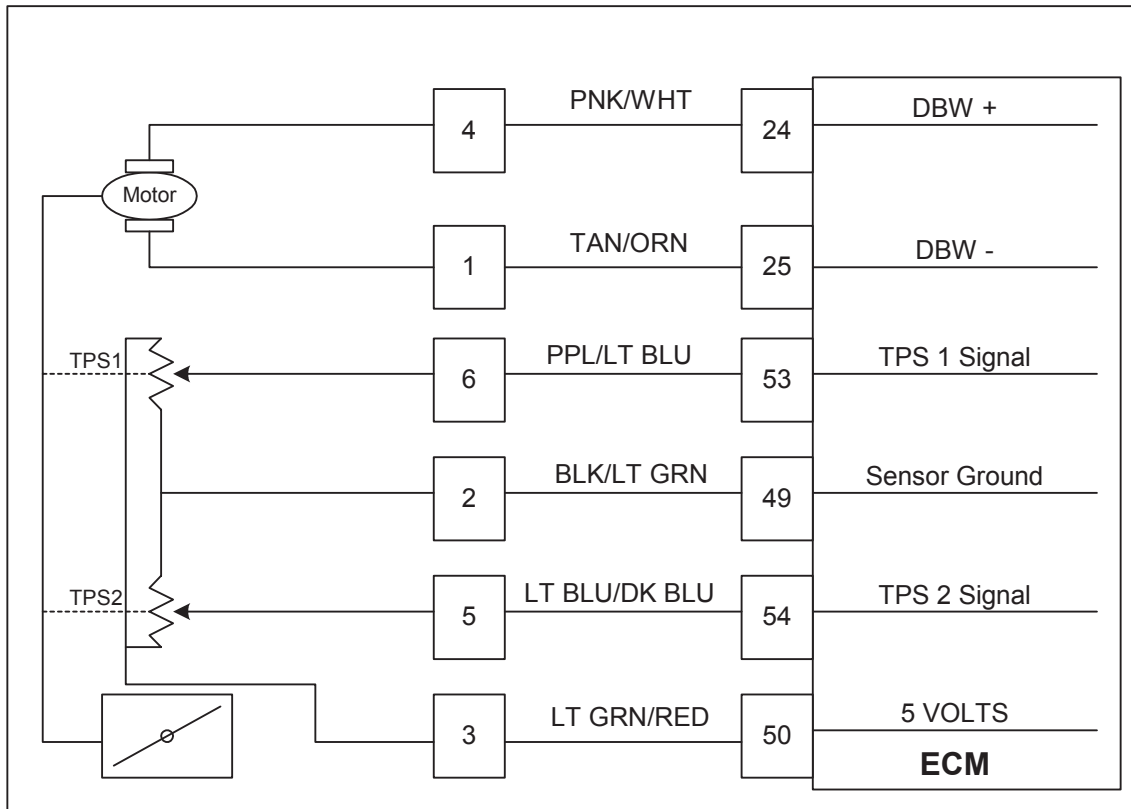

Conditions for Setting the DTC

- Throttle Position Sensor
- Check Condition-Cranking or Running
- Fault Condition-Throttle command is 20% less than throttle position for 200ms or longer
- MIL-On during active fault
- Adaptive-Enabled
- Closed Loop-Enabled
- Engine Shut Down

Circuit Description

There are 2 Throttle Position Sensors located within the throttle which use variable resistors to determine signal voltage based on throttle plate position. TPS1 will read low voltage when closed and TPS2 will read high voltage when closed. The TPS1 and TPS2 percentages are calculated from these voltages. Although the voltages are different, the calculated values for the throttle position percentages should be very close to the same. The TPS values are used by the ECM to determine if the throttle is opening as commanded. This fault will set if the throttle command is 20% less than the actual throttle position. During this active fault the MIL light will be on and the engine will shut down.

DTC 638 Throttle Unable to Close

Step	Action	Value(s)	Yes	No
1	Did you perform the On-Board (OBD) System Check?	-	Go to Step (2)	Go to OBD System Check Section
2	<ul style="list-style-type: none"> Key ON, Engine OFF DST (Diagnostic Scan Tool) connected in DBW (Drive By Wire) test mode Depress Foot Pedal until the Throttle Command is between 63%-68% Is the TPS 1 voltage greater than 2.0 volts?		Go to Step (3)	Intermittent problem Go to Intermittent section
3	<ul style="list-style-type: none"> Key OFF Disconnect wire harness connector from throttle Probe TPS 1 signal circuit with test light connected to battery voltage Key ON Does DST display TPS 1 voltage less than 0.2 volts?		Go to Step (6)	Go to Step (4)
4	<ul style="list-style-type: none"> Key OFF Disconnect ECM wire harness connector Key ON Using a DVOM check for voltage between throttle connector signal terminal and engine ground Do you have voltage?		Repair the circuit as necessary. Refer to Wiring Repairs in Engine Electrical.	Go to Step (5)
5	<ul style="list-style-type: none"> Replace ECM Is the replacement complete?		Go to Step (13)	-
6	<ul style="list-style-type: none"> Back probe sensor ground circuit at ECM connector with test light connected to battery voltage Does the test light come on?		Go to Step (9)	Go to Step (7)
7	<ul style="list-style-type: none"> Key OFF Disconnect ECM wire harness connector Using a DVOM check for continuity between throttle connector signal ground and ECM signal ground circuit terminals Do you have continuity between them?		Go to Step (8)	Repair the circuit as necessary. Refer to Wiring Repairs in Engine Electrical.
8	<ul style="list-style-type: none"> Replace ECM Is the replacement complete?		Go to Step (13)	-
9	<ul style="list-style-type: none"> Check throttle for foreign object in bore Did you find a foreign object in the bore?		Go to Step (10)	Go to Step (11)
10	<ul style="list-style-type: none"> Remove foreign object Is the removal complete?		Go to Step (13)	-
11	<ul style="list-style-type: none"> Inspect the throttle wire harness connector terminals for damage, corrosion or contamination Did you find the problem?		Repair the circuit as necessary. Refer to Wiring Repairs in Engine Electrical.	Go to Step (12)
12	<ul style="list-style-type: none"> Replace throttle Is the replacement complete?		Go to Step (13)	-

Step	Action	Value(s)	Yes	No
13	<ul style="list-style-type: none"> • Remove all test equipment except the DST. • Connect any disconnected components, fuses, etc. • Using the DST clear DTC information from the ECM. • Turn the ignition OFF and wait 30 seconds. • Start the engine and operate the vehicle to full operating temperature • Observe the MIL • Observe engine performance and driveability • After operating the engine within the test parameters of DTC-638 check for any stored codes. <p>Does the engine operate normally with no stored codes?</p>		System OK	Go to OBD System Check

DTC 651-Max Govern Speed Override

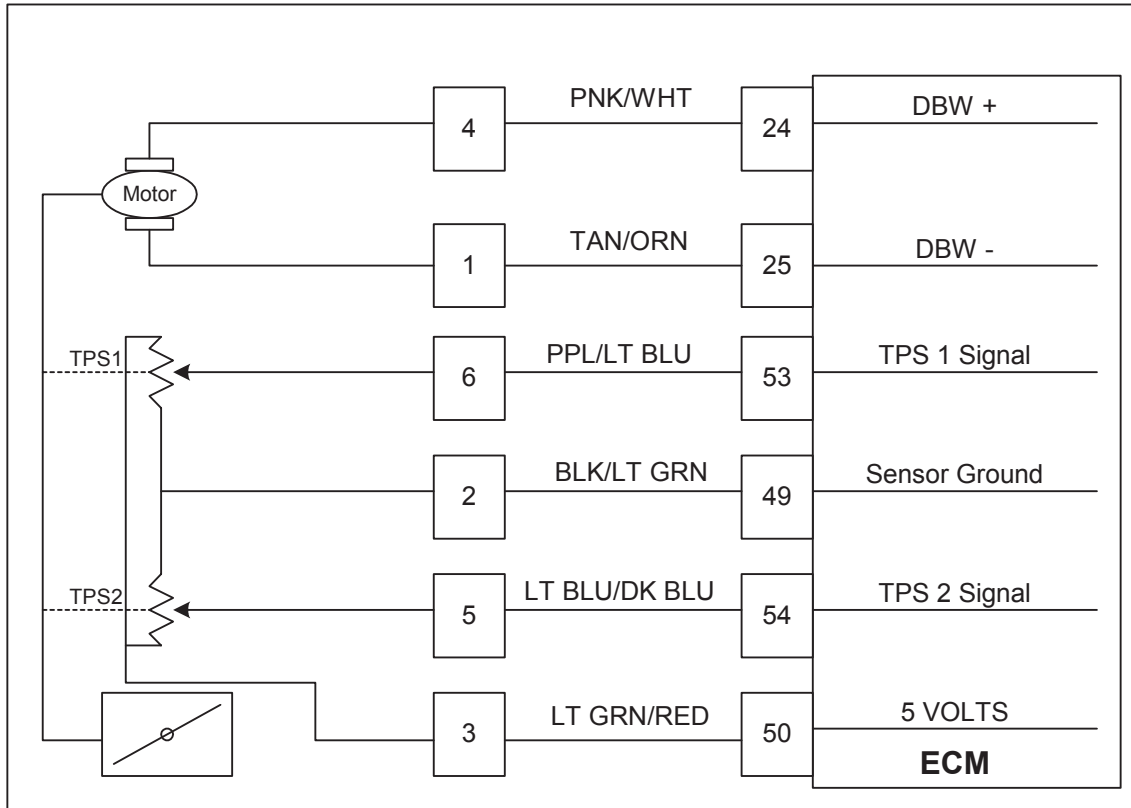

Conditions for Setting the DTC

- Max Govern Speed Override
- Check Condition- Engine Running
- Fault Condition- Engine RPM greater than 3800 for 2 seconds continuously
- MIL- On during active fault
- Adaptive- Enabled
- Closed Loop- Enabled

Circuit description

This fault will set anytime the engine RPM exceeds 3800 for 2 seconds or more continuously. This speed overrides any higher max governor speeds programmed by the user. This is to help prevent engine or equipment damage. The MIL will be on during this active fault.

DTC 651 Max Govern Speed Override

Step	Action	Value(s)	Yes	No
1	Did you perform the On-Board (OBD) System Check?	-	Go to Step (2)	Go to OBD System Check Section
2	<ul style="list-style-type: none"> • Key ON, Engine OFF • DST in Active Fault Mode Are any other DTC codes present with DTC 651?		Go to Step (3)	Go to Step (4)
3	<ul style="list-style-type: none"> • Diagnose any other DTC codes before proceeding with this chart. Have any other DTC codes been diagnosed and repaired?		Go to step (4)	-
4	<ul style="list-style-type: none"> • Check the Service Part Number on the ECM to ensure correct calibration is in use Is the Service Part Number Correct?		Go to Step (6)	Go to Step 5
5	<ul style="list-style-type: none"> • Replace ECM with correct Service Part Number Is the replacement complete?		Go to Step (9)	-
6	<ul style="list-style-type: none"> • Check the mechanical operation of the throttle Is the mechanical operation of the throttle OK?		Go to Step (8)	Go to Step (7)
7	<ul style="list-style-type: none"> • Correct mechanical operation of the throttle. Refer to Engine & Component R&R Section 1E Has the mechanical operation of the throttle been corrected?		Go to step (9)	-
8	<ul style="list-style-type: none"> • Check engine for large manifold vacuum leaks. Refer to Fuel Systems Section 1B Symptom Diagnostics Did you find and correct the vacuum leak?		Go to Step (9)	Go to OBD System Check Section
9	<ul style="list-style-type: none"> • Remove all test equipment except the DST. • Connect any disconnected components, fuses, etc. • Using the DST clear DTC information from the ECM. • Turn the ignition OFF and wait 30 seconds. • Start the engine and operate the vehicle to full operating temperature • Observe the MIL • Observe engine performance and driveability • After operating the engine within the test parameters of DTC-651 check for any stored codes. Does the engine operate normally with no stored codes?		System OK	Go to OBD System Check

DTC 652-Fuel Rev Limit

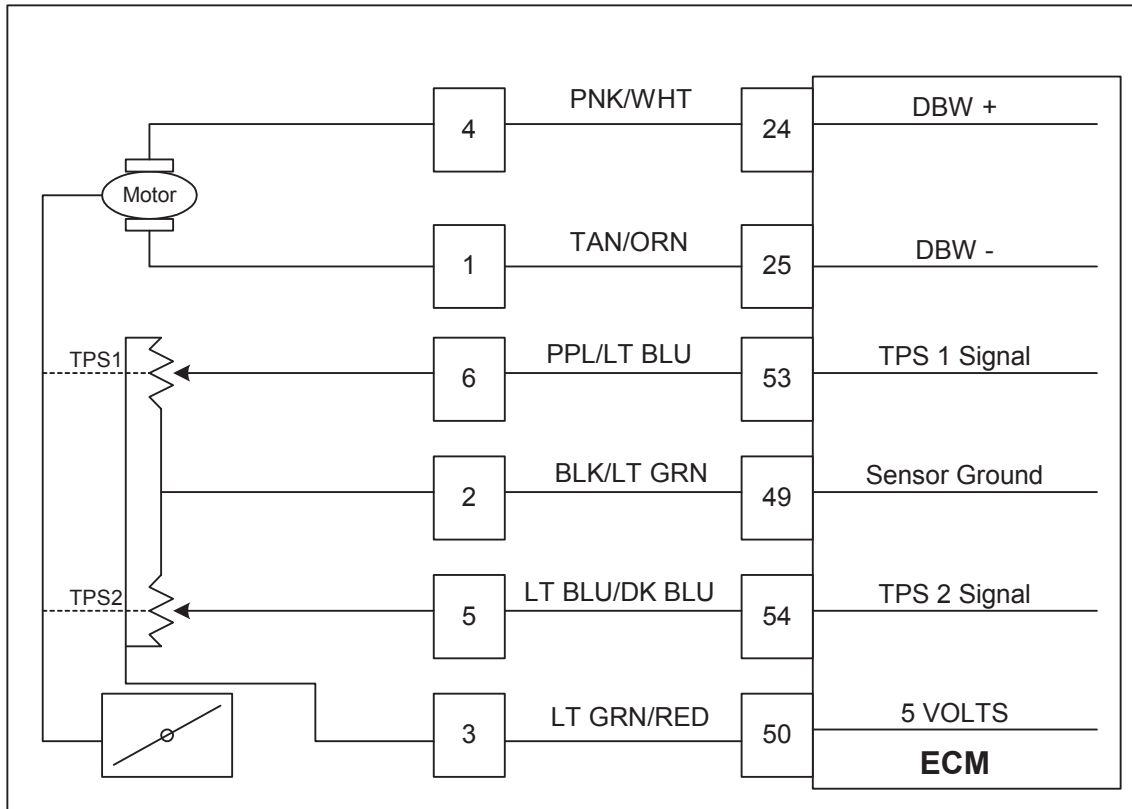

Conditions for Setting the DTC

- Fuel Rev Limit
- Check Condition- Engine Running
- Fault Condition- Engine RPM greater than 4000 for 2 seconds continuously
- MIL- On during active fault
- Adaptive- Enabled
- Closed Loop- Enabled

Circuit Description

This fault will set anytime engine RPM exceeds 4000 for 2 seconds or more continuously. When these conditions are met, the ECM shuts off the fuel injectors. This is to help prevent engine or equipment damage. The MIL will be on during this active fault.

DTC 652 Fuel Rev Limit

Step	Action	Value(s)	Yes	No
1	Did you perform the On-Board (OBD) System Check?	-	Go to Step (2)	Go to OBD System Check Section
2	<ul style="list-style-type: none"> • Key ON, Engine OFF • DST in Active Fault Mode Are any other DTC codes present with DTC 651?		Go to Step (3)	Go to Step (4)
3	<ul style="list-style-type: none"> • Diagnose any other DTC codes before proceeding with this chart. Have any other DTC codes been diagnosed and repaired?		Go to step (4)	-
4	<ul style="list-style-type: none"> • Check the Service Part Number on the ECM to ensure correct calibration is in use Is the Service Part Number Correct?		Go to Step (6)	Go to Step 5
5	<ul style="list-style-type: none"> • Replace ECM with correct Service Part Number Is the replacement complete?		Go to Step (9)	-
6	<ul style="list-style-type: none"> • Check the mechanical operation of the throttle Is the mechanical operation of the throttle OK?		Go to Step (8)	Go to Step (7)
7	<ul style="list-style-type: none"> • Correct mechanical operation of the throttle. Refer to Engine & Component R&R Section 1E Has the mechanical operation of the throttle been corrected?		Go to step (9)	-
8	<ul style="list-style-type: none"> • Check engine for large manifold vacuum leaks. Refer to Fuel Systems Section 1B Symptom Diagnostics Did you find and correct the vacuum leak?		Go to Step (9)	Go to OBD System Check Section
9	<ul style="list-style-type: none"> • Remove all test equipment except the DST. • Connect any disconnected components, fuses, etc. • Using the DST clear DTC information from the ECM. • Turn the ignition OFF and wait 30 seconds. • Start the engine and operate the vehicle to full operating temperature • Observe the MIL • Observe engine performance and driveability • After operating the engine within the test parameters of DTC-652 check for any stored codes. Does the engine operate normally with no stored codes?		System OK	Go to OBD System Check

DTC 653-Spark Rev Limit

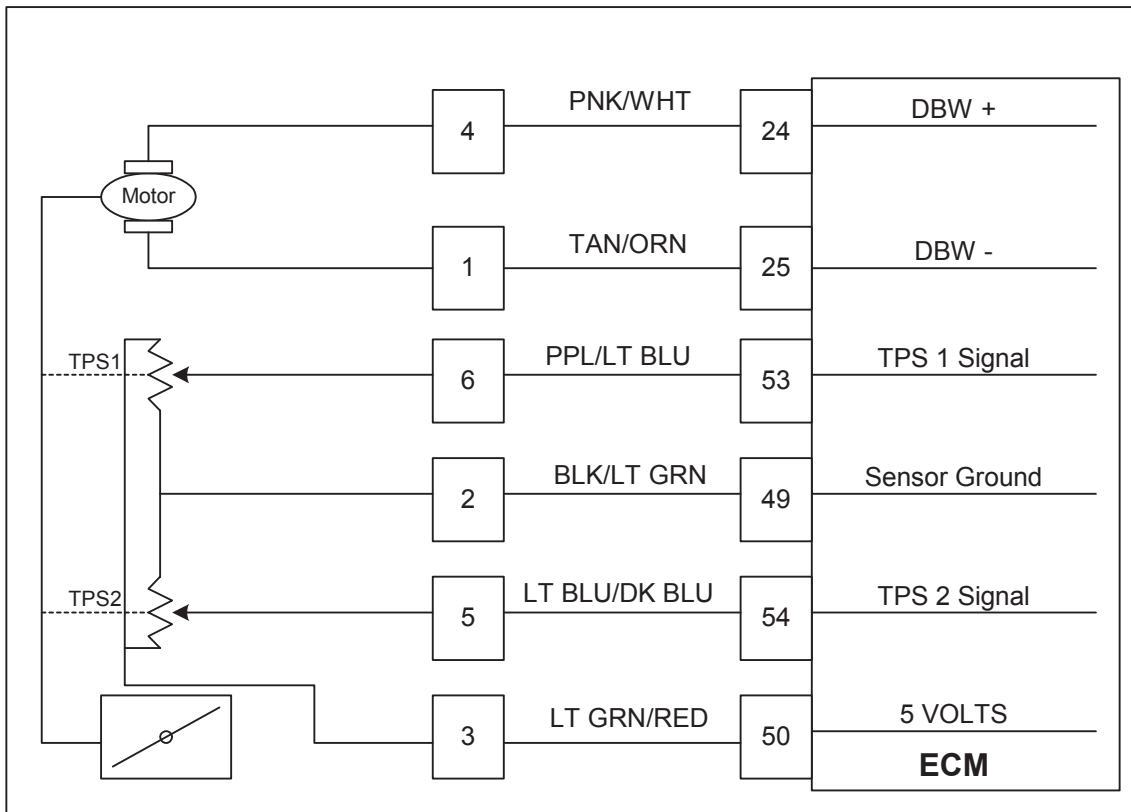

Conditions for Setting the DTC

- Spark Rev Limit
- Check Condition- Engine running
- Fault Condition- Engine RPM greater than 4100 for 2 seconds continuously
- MIL- On during active fault
- Adaptive- Enabled
- Closed Loop- Enabled

Circuit description

This fault will set anytime the engine RPM exceeds 4100 for 2 seconds or more continuously. When these conditions are met, the ECM will shut off spark to the engine. This is to help prevent engine or equipment damage. The MIL will be on during this active fault.

DTC 653 Spark Rev Limit

Step	Action	Value(s)	Yes	No
1	Did you perform the On-Board (OBD) System Check?	-	Go to Step (2)	Go to OBD System Check Section
2	<ul style="list-style-type: none"> • Key ON, Engine OFF • DST in Active Fault Mode Are any other DTC codes present with DTC 651?		Go to Step (3)	Go to Step (4)
3	<ul style="list-style-type: none"> • Diagnose any other DTC codes before proceeding with this chart. Have any other DTC codes been diagnosed and repaired?		Go to step (4)	-
4	<ul style="list-style-type: none"> • Check the Service Part Number on the ECM to ensure correct calibration is in use Is the Service Part Number Correct?		Go to Step (6)	Go to Step 5
5	<ul style="list-style-type: none"> • Replace ECM with correct Service Part Number Is the replacement complete?		Go to Step (9)	-
6	<ul style="list-style-type: none"> • Check the mechanical operation of the throttle Is the mechanical operation of the throttle OK?		Go to Step (8)	Go to Step (7)
7	<ul style="list-style-type: none"> • Correct mechanical operation of the throttle. Refer to Engine & Component R&R Section 1E Has the mechanical operation of the throttle been corrected?		Go to step (9)	-
8	<ul style="list-style-type: none"> • Check engine for large manifold vacuum leaks. Refer to Fuel Systems Section 1B Symptom Diagnostics Did you find and correct the vacuum leak?		Go to Step (9)	Go to OBD System Check Section
9	<ul style="list-style-type: none"> • Remove all test equipment except the DST. • Connect any disconnected components, fuses, etc. • Using the DST clear DTC information from the ECM. • Turn the ignition OFF and wait 30 seconds. • Start the engine and operate the vehicle to full operating temperature • Observe the MIL • Observe engine performance and driveability • After operating the engine within the test parameters of DTC-653 check for any stored codes. Does the engine operate normally with no stored codes?		System OK	Go to OBD System Check

Table of Contents

Engine Identification Code/Engine Number	3
Checking and Adjustment Operations	3
Ribbed V-belt Tension, Check	3
Compression, Check	3
Oil Pressure, Check	5
Timing, Check	6
Timing, Adjust	6
Toothed Belt Tension, Check	9
Toothed Belt Tension, Adjust	10
Toothed Belt Cover, Upper Part, Remove and Install	12
Toothed Belt Cover, Lower Part, Remove and Install	13
Toothed Belt, Remove and Install	14
Toothed Belt Tension Roller, Remove and Install	15
Seal Ring in Front Camshaft Housing, Replace	16
Rear Toothed Belt Cover, Remove and Install	18
Seal Ring in Rear Camshaft Housing, Replace	20
Exhaust Manifold, Remove and Install	21
Intake Manifold, Remove and Install	22
Camshaft and Cam Follower, Remove and Install (Cylinder Head Installed)	23
Hydraulic Valve Lifter, Replace (Cylinder Head Installed)	26
Camshaft, Remove and Install (Cylinder Head Removed)	27
Camshaft Housing, Replace	28
Camshaft Housing, Check for Plane Surface	30
Cylinder Head, Remove and Install	30
Cylinder Head, Check for Plane Surface	36
Flywheel/Flexplate, Remove and Install	37
Seal Ring – Rear Crankshaft, Replace	38
Piston with Con-rod, Remove and Install	39
Piston Rings, Remove and Install	43
Con-rod Bearing, Replace	45
Con-rod Bearing Clearance, Check (Determine Bearing Clearance with Plastigage)	46
Con-rod Bearing Clearance, Check (Determine Bearing Clearance with Micrometer and Inside Micrometer)	47
Piston, Replace	48
Crankshaft, Remove and Install	50
Crankshaft, Check	52
Crankshaft End Clearance, Check	52
Crankshaft Out-of-round, Check	52
Crankshaft Bearing Play, Check (Determine Bearing Play with Plastigage)	52
Crankshaft Bearing Clearance, Check (Determine Crankshaft Bearing Clearance Using External Micrometer and Inside Micrometer)	53
Cylinder Block, Check for Plane Surface	54
Oil Circuit	55
Oil Filter, Replace	55
Bypass Valve, Replace	55
Seal Ring – Oil Pump, Replace	55
Front Seal Ring – Crankshaft, Replace	55
Oil Pan, Remove and Install	58
Oil Pump, Remove and Install	59
Oil Pump, Check	62
Safety Valve, Remove and Install	63
Oil Intake Pipe, Remove and Install	64
Oil Baffle Plate, Remove and Install	64
Oil Pressure Switch, Remove and Install	65
Oil Dipstick Guide Tube, Remove and Install	65
Thermostat, Remove and Install	66
Coolant Pump, Remove and Install	68

Table of Contents

Coolant Pipe, Remove and Install.....	69
Engine Compartment Survey (Continued).....	71
Fuel Injector/Rail Remove.....	72
Fuel Injector/Rail Install.....	72
Crankshaft Position Sensor, Remove and Install.....	73
Reference Gap Between Crankshaft Pulse Pickup and Increment Disc, Check.....	74
Special Service Tools.....	75
Sealants, Lubricants and Locking Compounds.....	83
Technical Data.....	83
Specifications.....	83
Cylinder Head.....	84
Crank Drive, Cylinder Block.....	87
Engine Management.....	93
Recommended Torque Values.....	94

Engine Identification Code / Engine Number

The engine identification code is embossed on the flattened area (arrow) of the cylinder block on the transmission side.

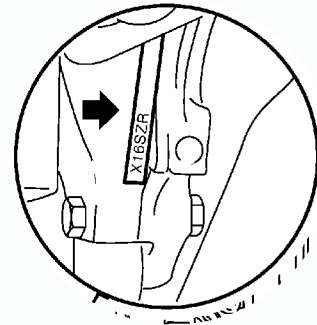

Checking and Adjustment Operations

Ribbed V-belt Tension, Check

Inspect

Ribbed V-belt tension is adjusted via automatic ribbed V-belt tensioner.

Only the position of the movable ribbed V-belt tensioner tensioning arm (1) can be checked. This should lie between the stops (2).

If movable tensioner arm (1) for ribbed V-belt tensioner is located at stop (2), replace ribbed V-belt and ribbed V-belt tensioner – see operations "Ribbed V-belt, Remove and Install" and "Ribbed V-belt Tensioner, Remove and Install".

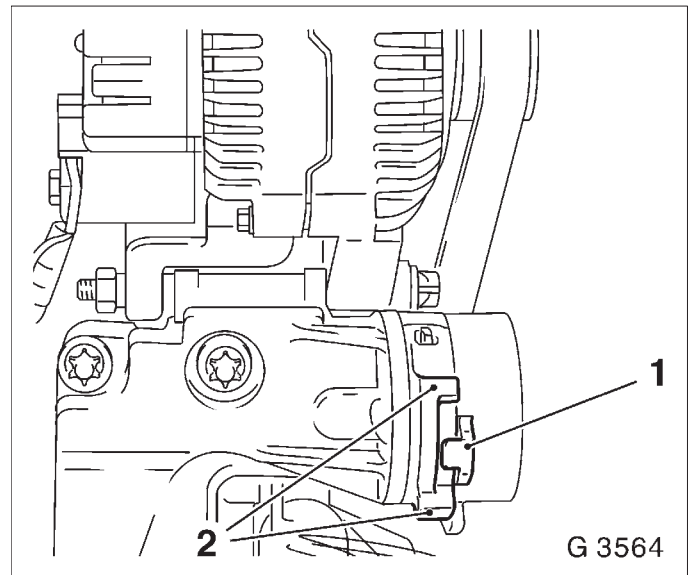

Compression, Check

Remove, Disconnect

Engine at operating temperature (oil temperature 80 °C).

Detach spark plug connectors and remove spark plugs with KM-194-E.

Detach wiring harness plug (1) from DIS ignition module.

Open relay holder cover and pull fuel pump relay (2) out of base.

Inspect

Use compression recorder with rubber cone and a measuring range of up to 1750 kPa (250 PSI) overpressure. Actuate starter for approx. 4 seconds with throttle valve fully open – minimum engine speed 300 rpm. The pressure difference between the individual cylinders should not exceed 100 kPa (14.5 PSI).

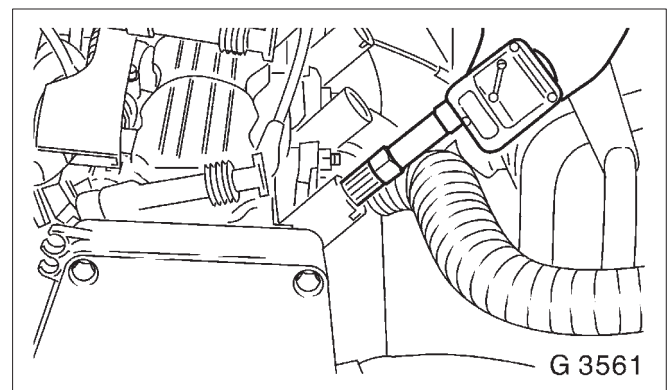

Install, Connect

Insert fuel pump relay in base and close relay holder cover.

Connect wiring harness plug to DIS ignition module.
Install spark plugs with KM-194-E into cylinder head – tightening torque 25 Nm / 18 lbf. ft.

Connect spark plug connectors.

Pressure Loss, Check

Engine at operating temperature (oil temperature 80 °C).

Remove, Disconnect

Detach spark plug connectors, remove spark plugs with KM-194-E.

Remove fluid filler opening sealing cap, coolant compensation tank sealing cap and oil dipstick.

Remove air cleaner housing with air intake cover.

Remove upper part of toothed belt cover – see operation "Toothed Belt Cover – Upper Part, Remove and Install".

Adjust

Set piston of 1st cylinder to TDC position. To determine

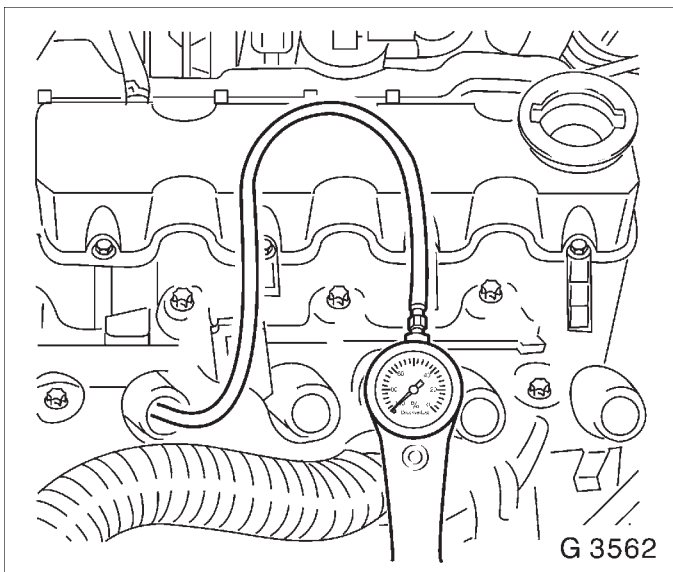

TDC position – see operation "Timing, Check".

Install, Connect

Connect pressure loss tester to compressed air system and calibrate.

Screw connector into spark plug bore of 1st cylinder and connect pressure loss tester with connector (observe manufacturer's instructions).

Important!

The crankshaft is not permitted to rotate during the test procedure.

Inspect

Air outlet at: inlet or exhaust side, compensation tank and crankcase housing. Max. difference in pressure between individual cylinders: 10%. The max. pressure loss of a cylinder should not exceed 25%.

Check pressure loss at 3rd, 4th and 2nd cylinders analogously. Bring piston of cylinder to be checked in "ign. TDC" position, ignition sequence: 1-3-4-2. Determine "ign. TDC" position by placing guide marks on camshaft sprocket. Further turn crankshaft 180° in engine rotational direction (corresponds to 90° at camshaft sprocket) up to camshaft sprocket guide mark and align toothed belt cover. Determine the "ign. TDC" position for 4th and 2nd cylinders analogously. Turn crankshaft slowly and uniformly.

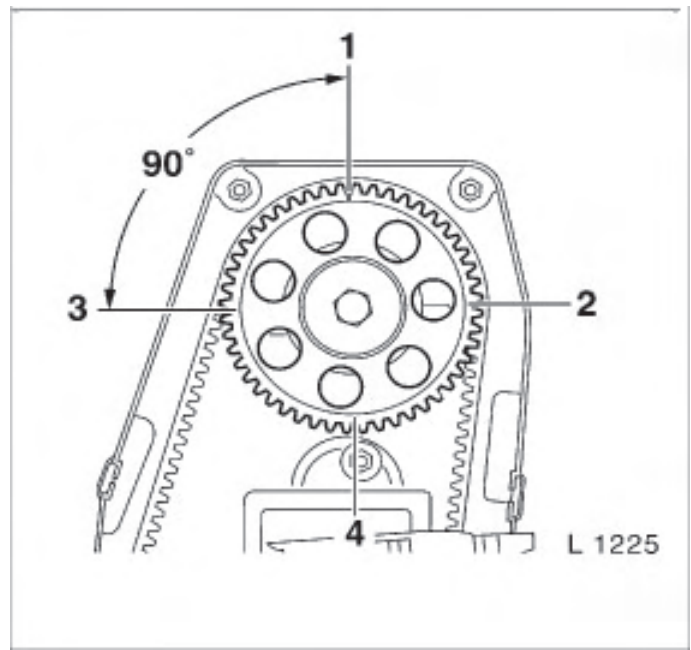
**Install, Connect**

Install upper part of toothed belt cover – see operation "Toothed Belt Cover – Upper Part, Remove and Install".

Install air cleaner housing with air intake cover.

Install spark plugs in cylinder head using KM-194-E – tightening torque 25 Nm / 18.5 lbf. ft.

Attach spark plug connector, fluid filler opening sealing cap, coolant compensation tank sealing cap and oil dipstick.

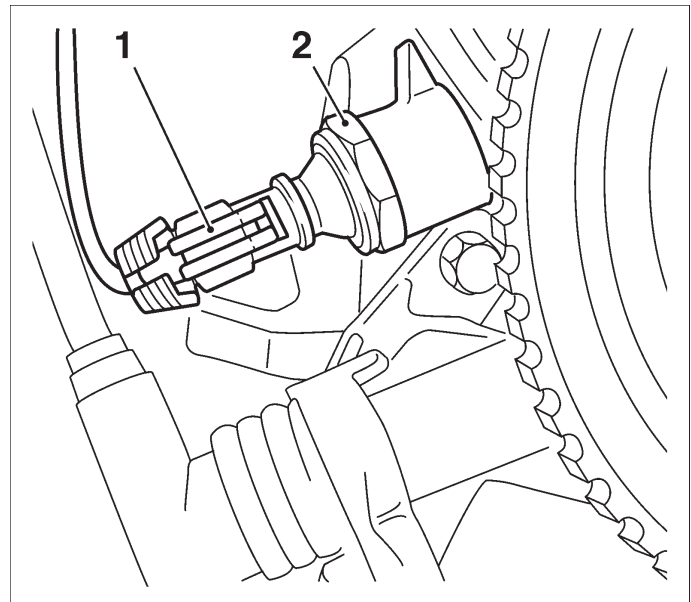
**Oil Pressure, Check****Remove, Disconnect**

Disconnect wiring harness plug (1) from oil pressure switch, remove oil pressure switch (2) – place collecting basin underneath.

Inspect

Check oil pressure with KM-498-B (3) and KM-135 (4). The oil pressure should be approx. 150 kPa (22 PSI) at idling speed with an oil temperature of 80 °C.

Install, Connect

Attach oil pressure switch to oil pump with new seal ring – tightening torque 30 Nm / 22 lbf. ft.

Connect wiring harness plug to oil pressure switch.

Check engine oil level and correct if necessary.

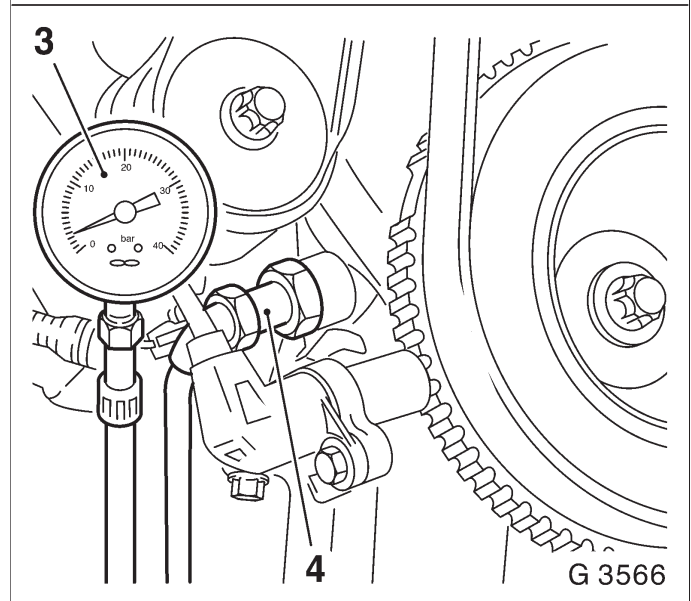

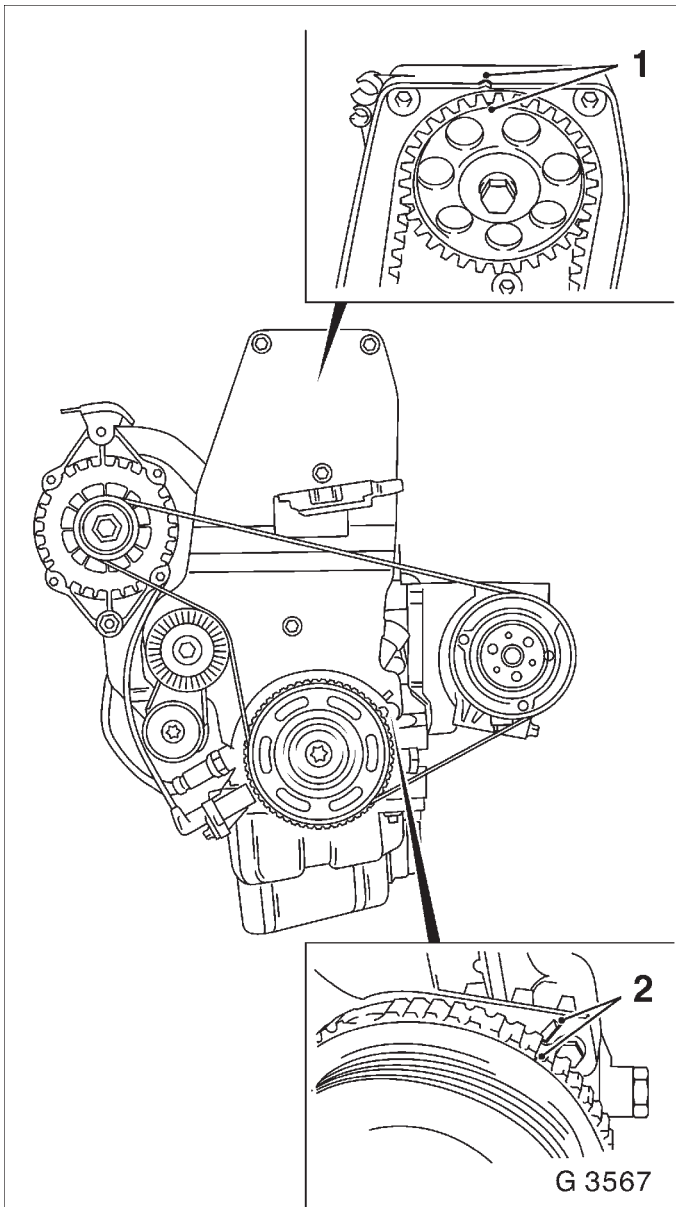

Timing, Check

Remove, Disconnect

Disconnect ground cable from battery.

Remove air cleaner housing with air intake cover.

Remove upper part of toothed belt cover – see operation "Toothed Belt Cover – Upper Part, Remove and Install".

Inspect

At fastening bolt of toothed belt drive gear, turn crankshaft in engine rotational direction to "1st cylinder TDC" (marking 2). At the same time, notches (1) on camshaft pulley and rear toothed belt cover must align. Turn crankshaft slowly and uniformly.

If the timing marks do not align – see operation "Timing, Adjust".

Install, Connect

Install upper part of toothed belt cover – see operation "Toothed Belt Cover – Upper Part, Remove and Install".

Install air cleaner housing with air intake cover.

Connect ground cable to battery.

Timing, Adjust

Note:

Adjustment is carried out with the engine cold – at room temperature.

Remove, Disconnect

Disconnect ground cable from battery.

Remove air cleaner housing with air intake cover.

Remove upper part of toothed belt cover – see operation "Toothed Belt Cover – Upper Part, Remove and Install".

Remove ribbed V-belts – see operation "Ribbed V-belts, Remove and Install".

Remove ribbed V-belt tensioner – see operation "Ribbed V-belt Tensioner, Remove and Install".

Remove lower part of toothed belt cover – see operation "Toothed Belt Cover – Lower Part, Remove and Install".

Remove, Disconnect

Remove engine PCV vacuum hose (1) from camshaft housing cover.

Remove wiring trough (2) from camshaft housing cover.

Remove camshaft housing cover (3) from camshaft housing.

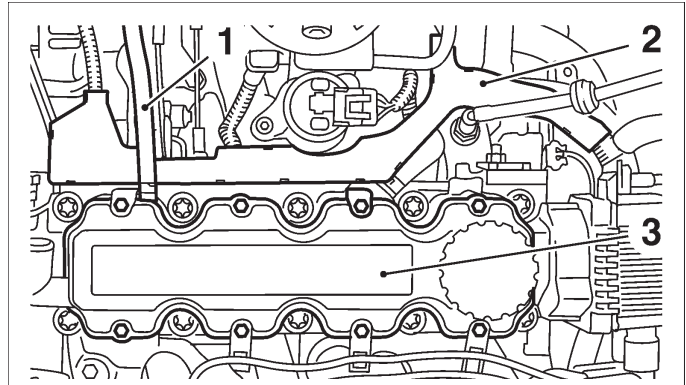

Adjust

Screw fastening bolt for toothed belt drive gear into crankshaft and turn crankshaft in engine rotational direction until pointer (4) on toothed belt drive gear is flush with mark on oil pump housing.

Move toothed belt tension roller against spring force upward until bore holes align. Fix toothed belt tension roller in place with suitable drift (5). Mark running direction (front edge) of toothed belt and remove toothed belt.

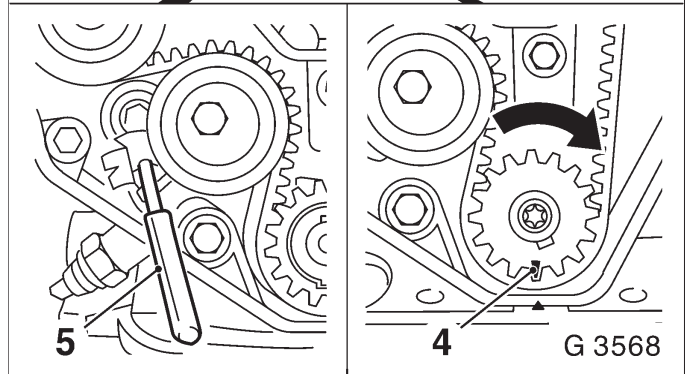
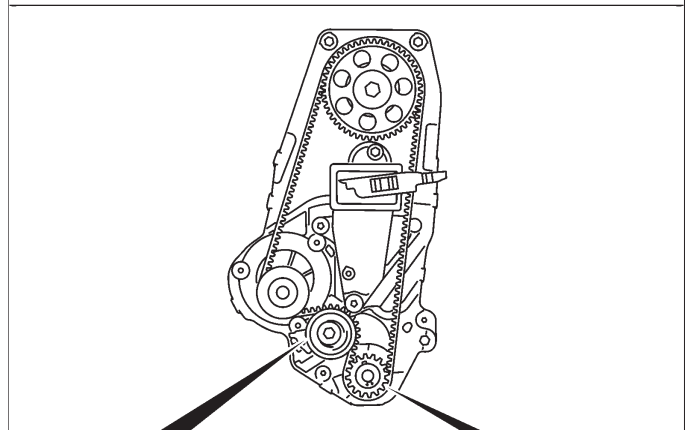

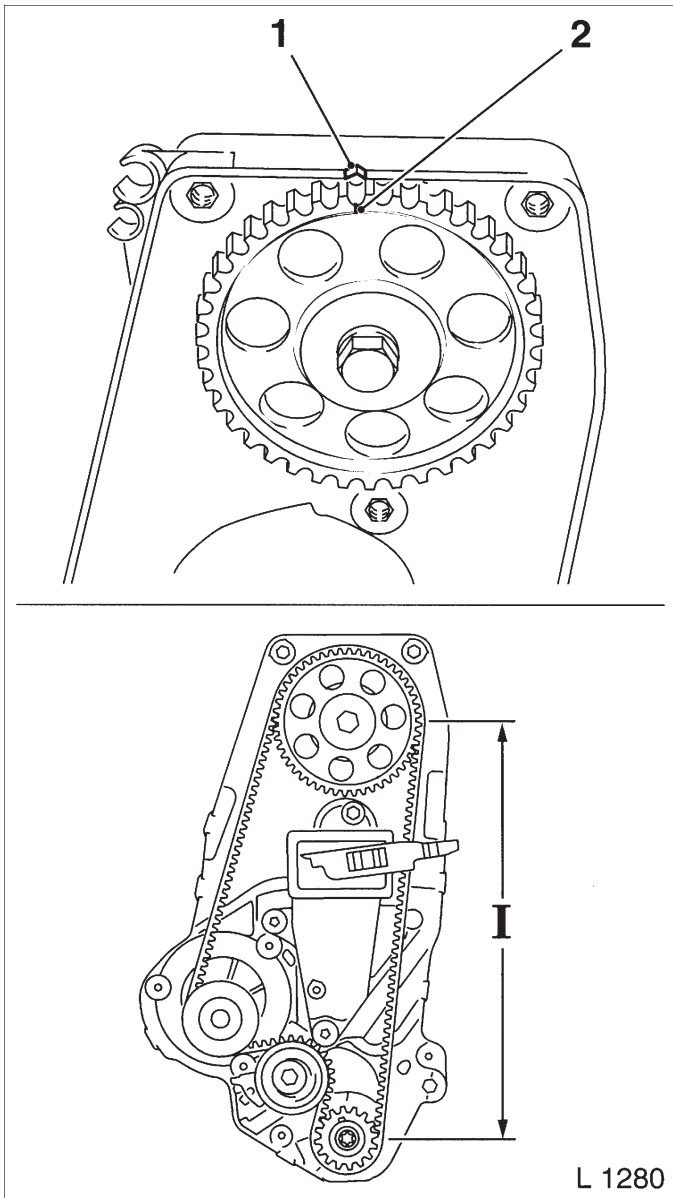
**Adjust**

At hex of camshaft, turn camshaft sprocket (short way) to mark. Notch (2) on camshaft sprocket must align with mark (1) on rear toothed belt cover.

Install, Connect

Attach toothed belt – ensure that tension side (I) is taut. Note running direction of toothed belt. Remove drift from toothed belt tension roller. Adjust toothed belt tension – see operation "Toothed Belt Tension, Adjust". Install camshaft housing cover at camshaft housing – tightening torque 8 Nm / 6 lbf. ft. Attach wiring trough to camshaft housing – tightening torque 8 Nm / 6 lbf. ft. Attach engine vacuum hose to camshaft housing cover.

Remove, Disconnect

Remove fastening bolt from toothed belt drive gear.

Install, Disconnect

Install lower part of toothed belt cover – see operation "Toothed Belt Cover – Lower Part, Remove and Install".

Install ribbed V-belt tensioner – see operation "Ribbed V-belt Tensioner, Remove and Install".

Install ribbed V-belt – see operation "Ribbed V-belt, Remove and Install".

Install upper part of toothed belt cover – see operation "Toothed Belt Cover – Upper Part, Remove and Install".

Install air cleaner housing with air intake cover.

Connect ground cable to battery.

Toothed Belt Tension, Check

Note:

Testing is performed with the engine cold – at room temperature.

Remove, Disconnect

Disconnect ground cable from battery.

Remove air cleaner housing with air intake cover

Remove upper part of toothed belt cover – see operation "Toothed Belt Cover – Upper Part, Remove and Install".

Remove ribbed V-belts – see operation "Ribbed V-belts, Remove and Install".

Remove ribbed V-belt tensioner – see operation "Ribbed V-belt Tensioner, Remove and Install".

Remove, Disconnect

Remove lower part of toothed belt cover – see operation "Toothed Belt Cover – Lower Part, Remove and Install".

Adjust

Screw fastening bolts of toothed belt drive gear into crankshaft and turn crankshaft in engine rotational direction until pointer (3) aligns with mark on oil pump housing. At the same time, notch (2) on camshaft pulley must be aligned with mark (1) on rear toothed belt cover.

Inspect

The toothed belt tension is correctly adjusted when the pointer (4) of the movable part of the toothed belt tension roller aligns with notch (arrow).

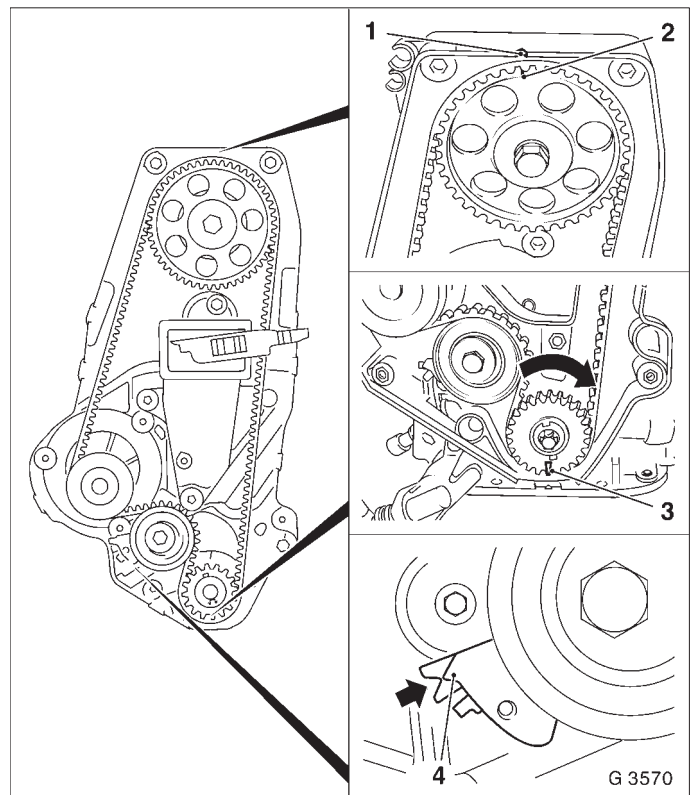

Inspect

If the toothed belt tension is not correctly adjusted – see operation "Toothed Belt Tension, Adjust".

Remove, Disconnect

Remove fastening bolt from toothed belt drive gear.

Install, Disconnect

Install lower part of toothed belt cover – see operation "Toothed Belt Cover – Lower Part, Remove and Install".

Install ribbed V-belt tensioner – see operation "Ribbed V-belt Tensioner, Remove and Install".

Install ribbed V-belt – see operation "Ribbed V-belt, Remove and Install".

Install upper part of toothed belt cover – see operation "Toothed Belt Cover – Upper Part, Remove and Install".

Install air cleaner housing with air intake cover.

Connect ground cable to battery.

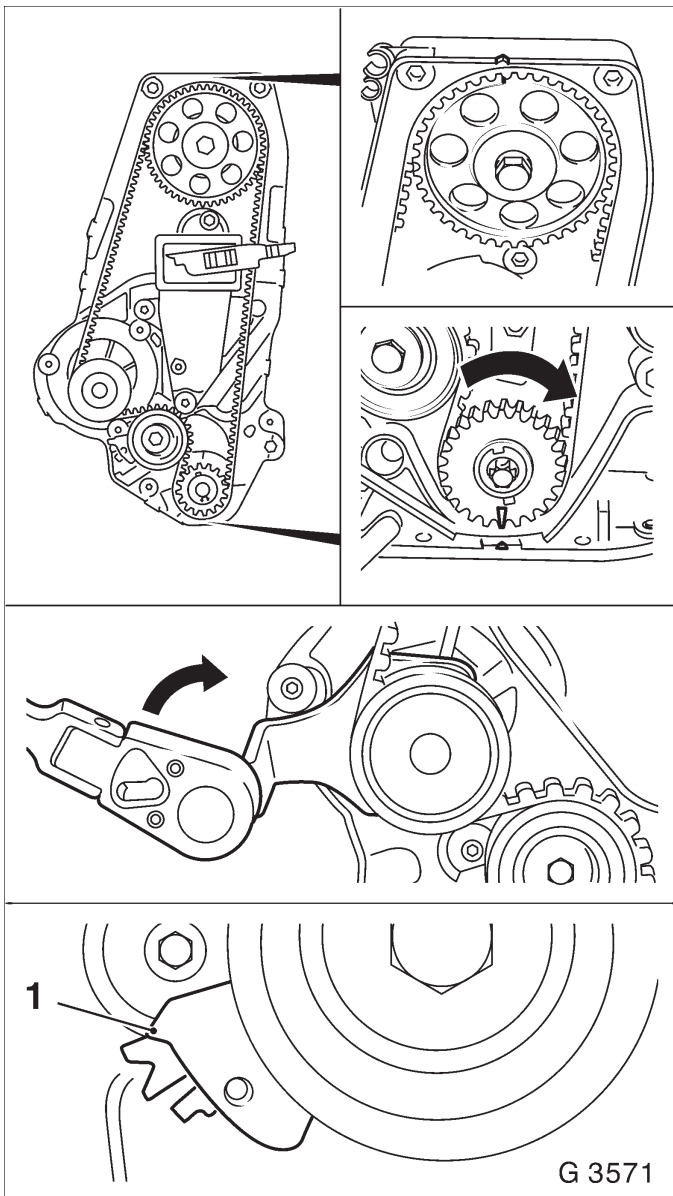

Toothed Belt Tension, Adjust

Note:

Testing is performed with the engine cold – at room temperature.

Remove, Disconnect

Remove air cleaner housing with air intake cover

Remove upper part of toothed belt cover – see operation "Toothed Belt Cover – Upper Part, Remove and Install".

Remove ribbed V-belts – see operation "Ribbed V-belts, Remove and Install".

Remove ribbed V-belt tensioner – see operation "Ribbed V-belt Tensioner, Remove and Install".

Remove, Disconnect

Remove lower part of toothed belt cover – see operation "Toothed Belt Cover – Lower Part, Remove and Install".

Adjust

Screw fastening bolt for toothed belt drive gear into crankshaft and turn crankshaft in engine rotational direction until pointer on toothed belt drive gear is flush with mark on oil pump housing. At the same time, notch on camshaft pulley must be flush with mark on rear toothed belt cover.

Release fastening bolts for coolant pump. Tension toothed belt by turning coolant pump in direction of arrow (clockwise) with KM-421-A until pointer (1) is at right stop.

G 3571

Adjust

Turn crankshaft two revolutions (720°) in engine rotational direction, until timing marks align. Turn crankshaft slowly and uniformly and do not change position of coolant pump.

Reduce toothed belt tension by turning coolant pump in direction of arrow with KM-421-A until pointer (1) and notch (2) on toothed belt tension roller carrier plate align. Set crankshaft another two revolutions (720°) in engine rotational direction to mark "1st cylinder ignition TDC" and check adjustment of toothed belt tension roller. If marks do not align, repeat adjustment procedure.

Tighten (Torque)

Coolant pump to cylinder block – tightening torque 8 Nm / 6 lbf. ft.

Install, Connect

Remove fastening bolt from toothed belt drive gear and install toothed belt cover, lower part – see operation "Toothed Belt Cover, Lower Part, Remove and Install".

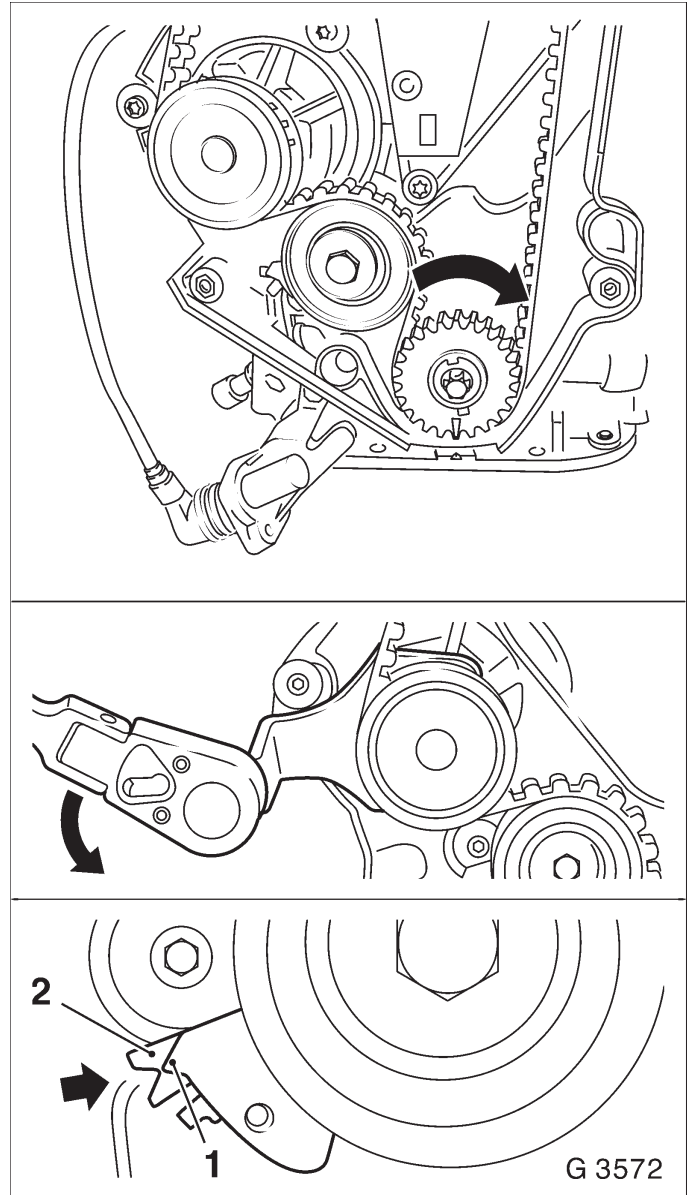
**Install, Connect**

Install ribbed V-belt tensioner – see operation "Ribbed V-belt Tensioner, Remove and Install".

Install ribbed V-belt – see operation "Ribbed V-belt, Remove and Install".

Install upper part of toothed belt cover – see operation "Toothed Belt Cover – Upper Part, Remove and Install".

Install air cleaner housing with air intake cover.

Check cooling system for leaks.

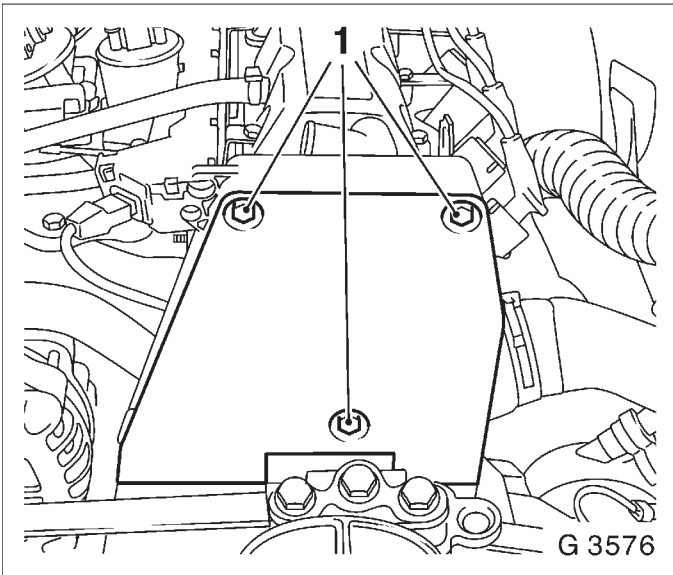

Toothed Belt Cover, Upper Part, Remove and Install

Remove, Disconnect

Remove air cleaner housing with air intake cover.

Remove fastening bolts (1) and remove upper part of toothed belt cover from rear toothed belt cover.

Install, Connect

Attach upper part of toothed belt cover to rear toothed belt cover – tightening torque 4 Nm / 3 lbf. ft.

Install air cleaner housing with air intake cover.

Toothed Belt Cover, Lower Part, Remove and Install

Remove, Disconnect

Remove air cleaner housing with air intake cover.

Remove upper part of toothed belt cover – see operation "Toothed Belt Cover – Upper Part, Remove and Install".

Remove ribbed V-belts – see operation "Ribbed V-belts, Remove and Install".

Remove ribbed V-belt tensioner – see operation "Ribbed V-belt Tensioner, Remove and Install".

Lock drive disk or flywheel with KM-911 (1).

Detach crankshaft pulley/reluctor wheel (2) from crankshaft.

Remove fastening bolts (3) and remove lower part of toothed belt cover from rear toothed belt cover.

Install, Connect

Attach lower part of toothed belt cover to rear toothed belt cover – tightening torque 4 Nm / 3 lbf. ft.

Attach crankshaft pulley/reluctor wheel with new fastening bolt to crankshaft – tightening torque 95 Nm / 70 lbf. ft. + 30° + 15°.

Remove Locking Tool KM-911.

Install ribbed V-belt tensioner – see operation "Ribbed V-belt Tensioner, Remove and Install".

Install ribbed V-belt – see operation "Ribbed V-belt, Remove and Install".

Install upper part of toothed belt cover – see operation "Toothed Belt Cover – Upper Part, Remove and Install".

Install air cleaner housing with air intake cover.

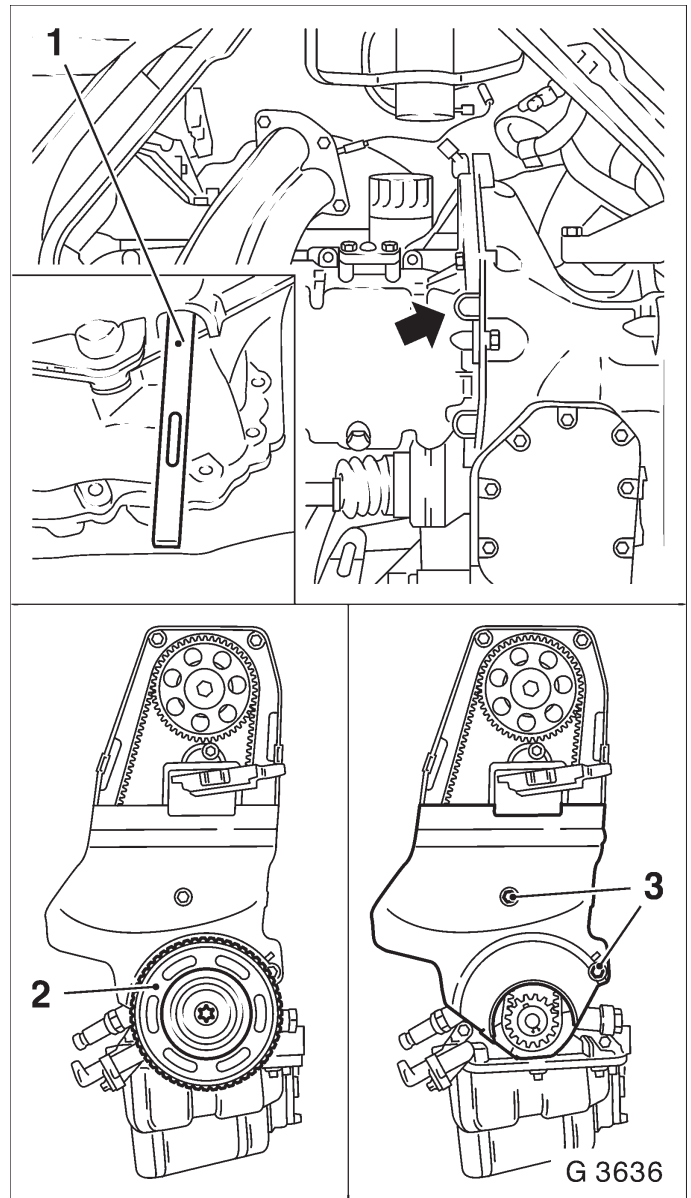

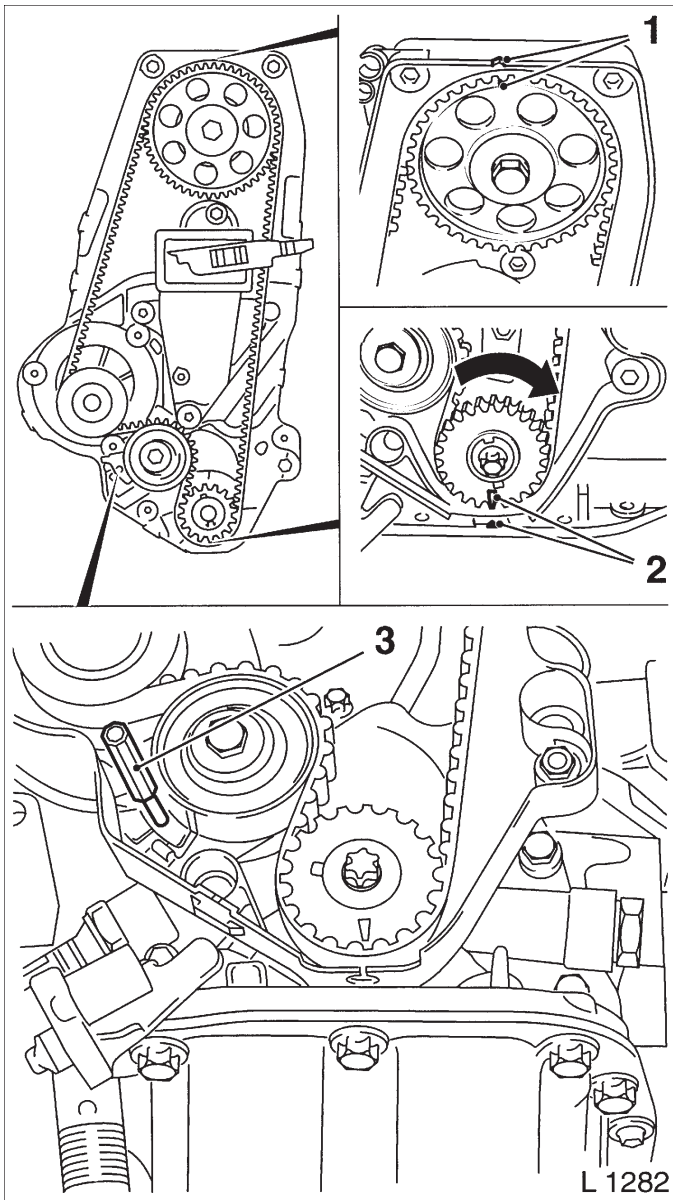

Toothed Belt, Remove and Install

Remove, Disconnect

Remove air cleaner housing with air intake cover.

Remove upper part of toothed belt cover – see operation "Toothed Belt Cover – Upper Part, Remove and Install".

Remove ribbed V-belts – see operation "Ribbed V-belts, Remove and Install".

Remove ribbed V-belt tensioner – see operation "Ribbed V-belt Tensioner, Remove and Install".

Remove lower part of toothed belt cover – see operation "Toothed Belt Cover – Lower Part, Remove and Install".

Adjust

Screw fastening bolt for toothed belt drive gear into crankshaft and turn crankshaft in engine rotational direction until marks (2) on toothed belt drive gear and oil pump housing are flush.

At the same time, notches (1) on camshaft pulley and rear toothed belt cover must be flush.

Turn crankshaft slowly and smoothly.

Remove, Disconnect

Move toothed belt tension roller upward against spring force until bore holes align. Fix toothed belt tension roller in place with suitable drift (3).

Mark running direction (front edge) of the toothed belt for identification and remove toothed belt.

Install, Connect

Check toothed belt for wear – replace if necessary.

Install toothed belt – ensure that tensioned side (I) is taut.

Observe timing marks. Adjust toothed belt tension – see operation "Toothed Belt Tension, Adjust".

Install, Connect

Remove fastening bolt from toothed belt drive gear and install toothed belt cover, lower part – see operation "Toothed Belt Cover, Lower Part, Remove and Install".

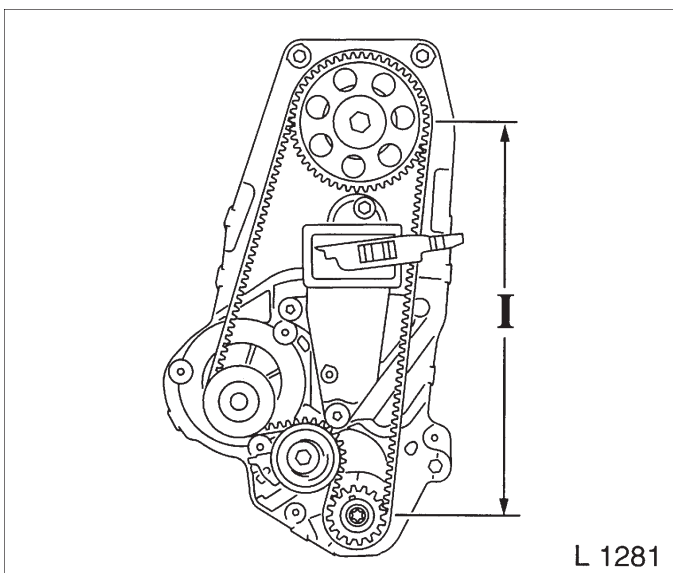

Install, Connect

Install ribbed V-belt tensioner – see operation "Ribbed V-belt Tensioner, Remove and Install".

Install ribbed V-belt – see operation "Ribbed V-belt, Remove and Install".

Install upper part of toothed belt cover – see operation "Toothed Belt Cover – Upper Part, Remove and Install".

Install air cleaner housing with air intake cover.

Toothed Belt Tension Roller, Remove and Install

Remove, Disconnect

Remove air cleaner housing with air intake cover.

Remove upper part of toothed belt cover – see operation "Toothed Belt Cover – Upper Part, Remove and Install".

Remove ribbed V-belts – see operation "Ribbed V-belts, Remove and Install".

Remove ribbed V-belt tensioner – see operation "Ribbed V-belt Tensioner, Remove and Install".

Remove lower part of toothed belt cover – see operation "Toothed Belt Cover – Lower Part, Remove and Install".

Remove toothed belt – see operation "Toothed Belt, Remove and Install".

Remove toothed belt tension roller (1) from oil pump.

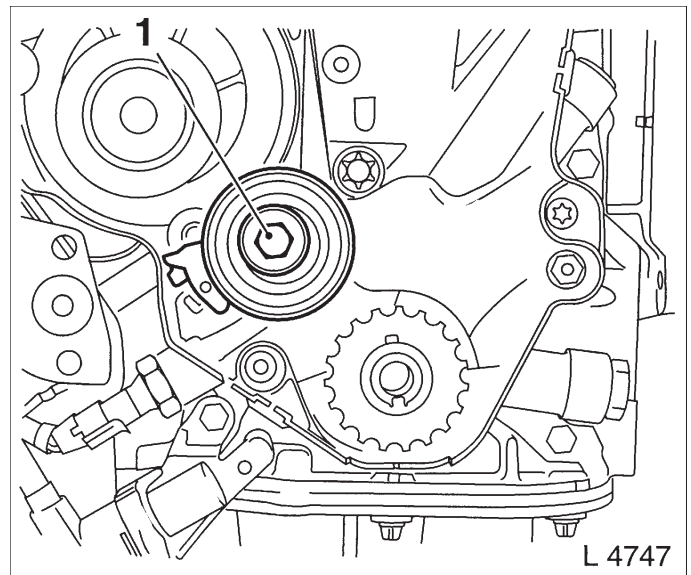

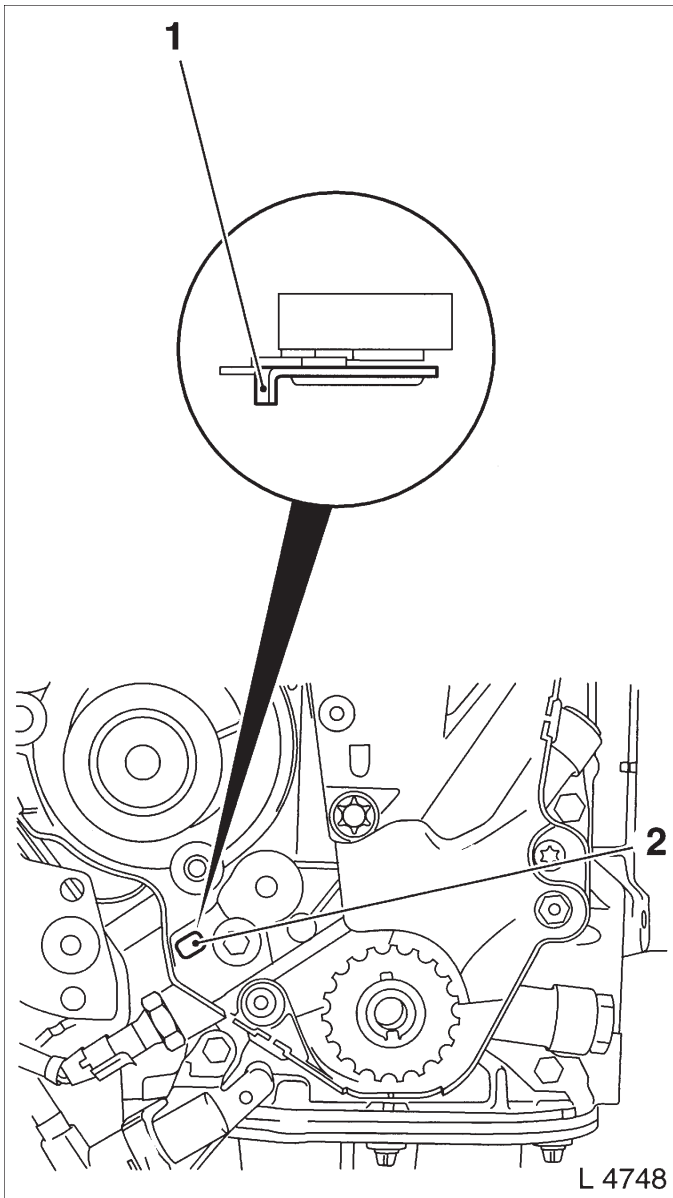
**Install, Connect**

Install toothed belt tension roller – make sure that lug (1) of toothed belt tension roller base plate engages in groove (2) of oil pump.

Attach toothed belt tension roller to oil pump – tightening torque 20 Nm / 15 lbf. ft.

Install toothed belt – see operation "Toothed Belt, Remove and Install".

Install lower part of toothed belt cover – see operation "Toothed Belt Cover – Lower Part, Remove and Install".

Install ribbed V-belt tensioner – see operation "Ribbed V-belt Tensioner, Remove and Install".

Install, Connect

Install ribbed V-belt – see operation "Ribbed V-belt, Remove and Install".

Install upper part of toothed belt cover – see operation "Toothed Belt Cover – Upper Part, Remove and Install".

Install air cleaner housing with air intake cover.

Seal Ring in Front Camshaft Housing, Replace**Remove, Disconnect**

Remove air cleaner housing with air intake cover.

Remove upper part of toothed belt cover – see operation "Toothed Belt Cover – Upper Part, Remove and Install".

Remove ribbed V-belts – see operation "Ribbed V-belts, Remove and Install".

Remove ribbed V-belt tensioner – see operation "Ribbed V-belt Tensioner, Remove and Install".

Remove lower part of toothed belt cover – see operation "Toothed Belt Cover – Lower Part, Remove and Install".

Remove toothed belt – see operation "Toothed Belt, Remove and Install".

Remove, Disconnect

Remove engine vent hose from camshaft housing cover.

Detach wiring trough from camshaft housing cover.

Remove camshaft housing cover from camshaft housing.

Remove camshaft sprocket (1) from camshaft – (hold with open-ended wrench on hex of camshaft).

Edge out seal ring (2) with suitable tool.

Important!

Do not damage sealing surfaces.

Install, Connect

Lightly coat sealing lip of seal ring with silicon grease (white). Press seal ring with KM-422 (3) in camshaft housing – use bolt and washer of camshaft pulley.

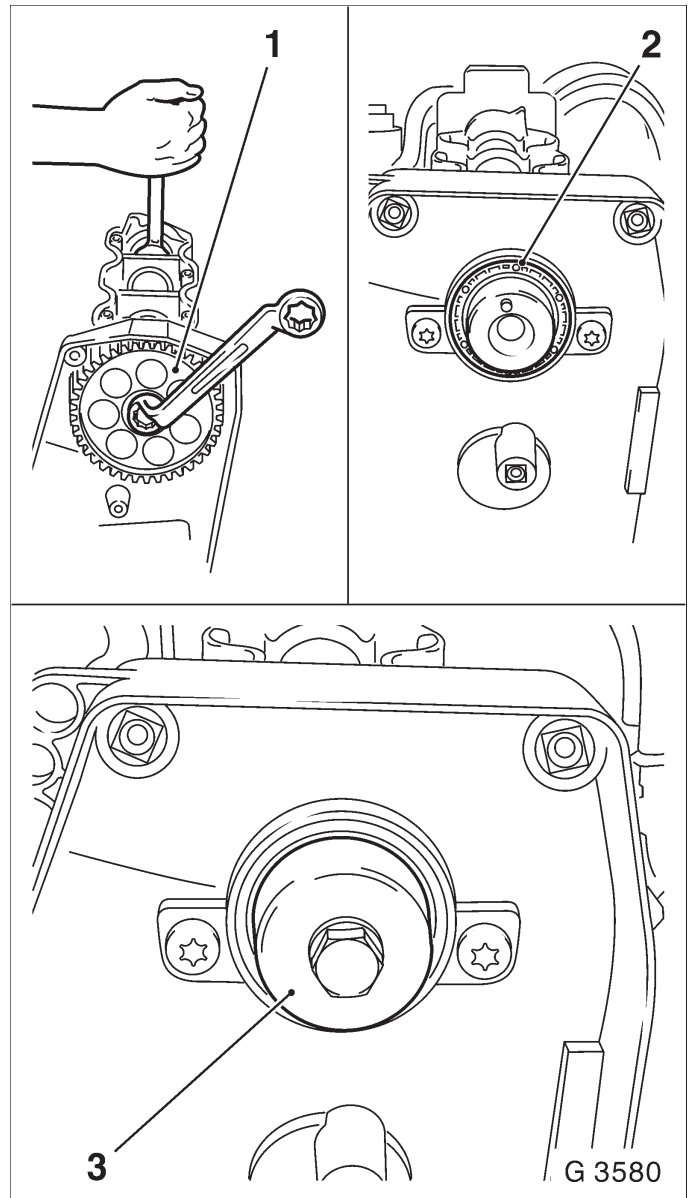
**Install, Connect**

Attach camshaft sprocket to camshaft – hold with open-ended wrench on hex of camshaft – tightening torque 45 Nm / 33 lbf. ft.

Install camshaft housing cover at camshaft housing – tightening torque 8 Nm / 6 lbf. ft.

Attach engine vacuum hose to camshaft housing cover.

Install toothed belt – see operation "Toothed Belt, Remove and Install".

Install lower part of toothed belt cover – see operation "Toothed Belt Cover – Lower Part, Remove and Install".

Install ribbed V-belt tensioner – see operation "Ribbed V-belt Tensioner, Remove and Install".

Install ribbed V-belt – see operation "Ribbed V-belt, Remove and Install".

Install upper part of toothed belt cover – see operation "Toothed Belt Cover – Upper Part, Remove and Install".

Install air cleaner housing with air intake cover.

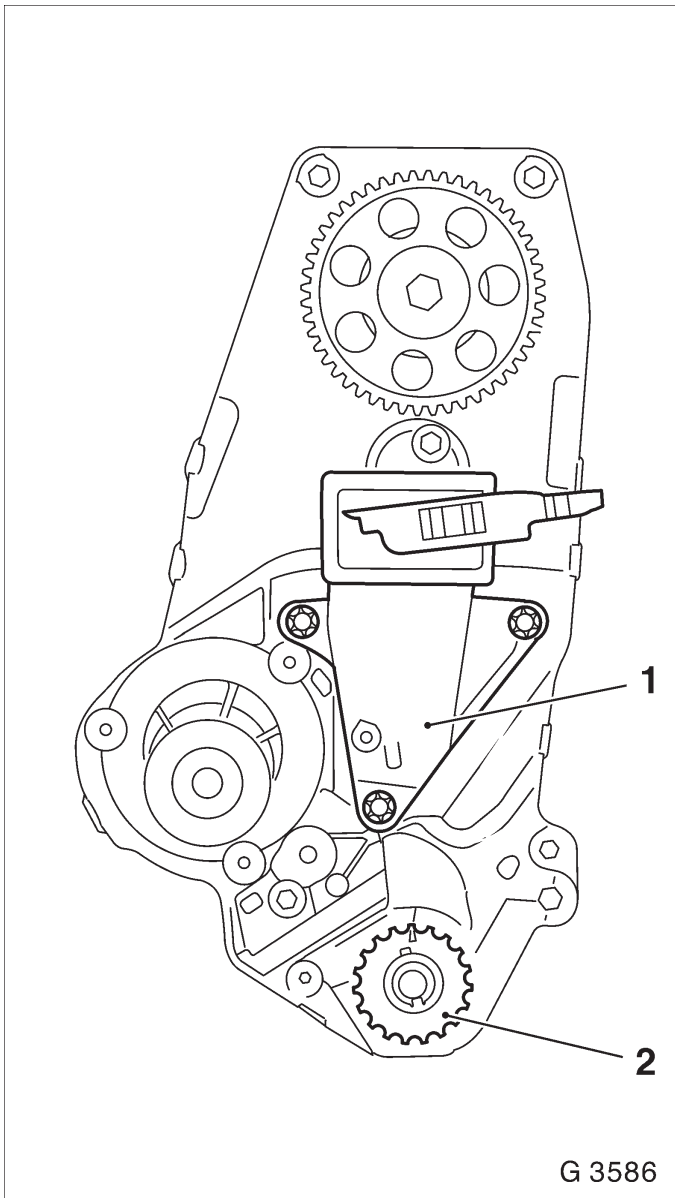

Rear Toothed Belt Cover, Remove and Install

Remove, Disconnect

Remove air cleaner housing with air intake cover.

Remove upper part of toothed belt cover – see operation "Toothed Belt Cover – Upper Part, Remove and Install".

Remove ribbed V-belts – see operation "Ribbed V-belts, Remove and Install".

Remove ribbed V-belt tensioner – see operation "Ribbed V-belt Tensioner, Remove and Install".

Remove lower part of toothed belt cover – see operation "Toothed Belt Cover – Lower Part, Remove and Install".

Remove toothed belt – see operation "Toothed Belt, Remove and Install".

Remove toothed belt tension roller – see operation "Toothed Belt Tension Roller, Remove and Install".

Remove toothed belt drive gear (2) from crankshaft. Detach engine damping block support (1) from cylinder block.

Remove, Disconnect

- Remove engine vacuum hose (1) from camshaft housing cover.
- Remove camshaft housing cover (3) from camshaft housing.
- Remove camshaft sprocket – hold with open-ended wrench on hex of camshaft.
- Unclip cable for crankshaft position sensor from rear toothed belt cover.
- Remove rear toothed belt cover (arrows) from oil pump and camshaft housing.

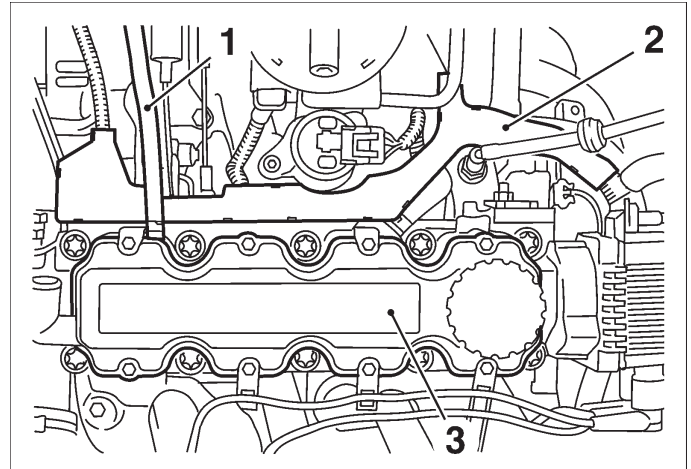

Install, Connect

- Attach rear toothed belt cover to oil pump and camshaft housing – tightening torque 6 Nm / 4 lbf. ft.

Install, Connect

Clip cable for crankshaft position sensor to rear toothed belt cover – note cable routing.

Attach camshaft sprocket to camshaft – hold with open-ended wrench on hex of camshaft – tightening torque 45 Nm / 33 lbf. ft.

Install camshaft housing cover at camshaft housing – tightening torque 8 Nm / 6 lbf. ft.

Attach engine vacuum hose to camshaft housing cover.

Attach engine damping block support to cylinder block – tightening torque 50 Nm / 37 lbf. ft.

Slide toothed belt drive gear onto crankshaft journal – note installation position.

Install toothed belt tension roller – see operation "Toothed Belt Tension Roller, Remove and Install".

Install toothed belt – see operation "Toothed Belt, Remove and Install".

Install lower part of toothed belt cover – see operation "Toothed Belt Cover – Lower Part, Remove and Install".

Install, Connect

Install ribbed V-belt tensioner – see operation "Ribbed V-belt Tensioner, Remove and Install".

Install ribbed V-belt – see operation "Ribbed V-belt, Remove and Install".

Install upper part of toothed belt cover – see operation "Toothed Belt Cover – Upper Part, Remove and Install".

Install air cleaner housing with air intake cover.

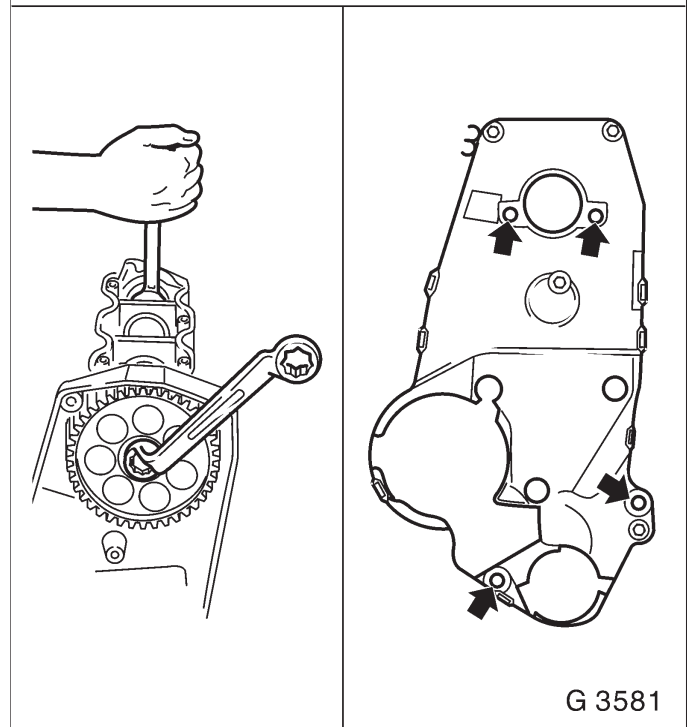

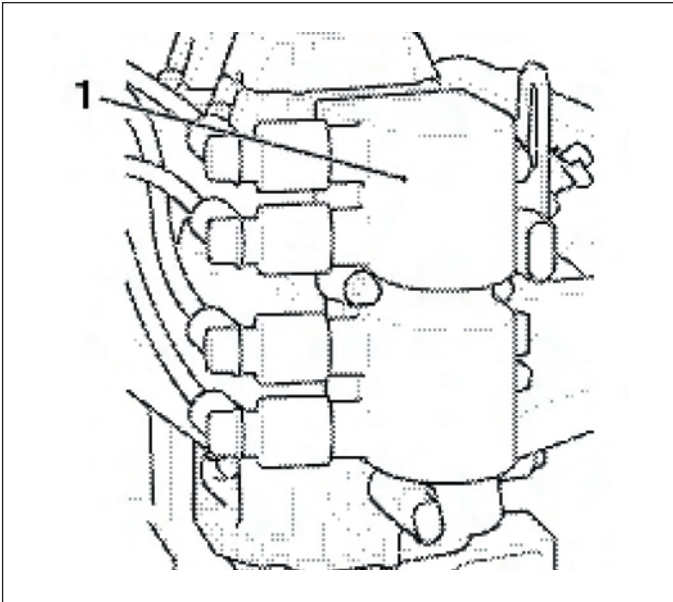

Seal Ring in Rear Camshaft Housing, Replace

Remove, Disconnect

Remove DIS ignition module (1). Remove carrier plate (2) from camshaft housing.

Clean

Clean sealing surfaces and remove gasket remnants.

Install, Connect

Coat seal ring (3) of carrier plate with silicone grease (white) and attach carrier plate to camshaft housing – tightening torque 12 Nm / 9 lbf. ft.

Install DIS ignition module – tightening torque 12 Nm / 9 lbf. ft.

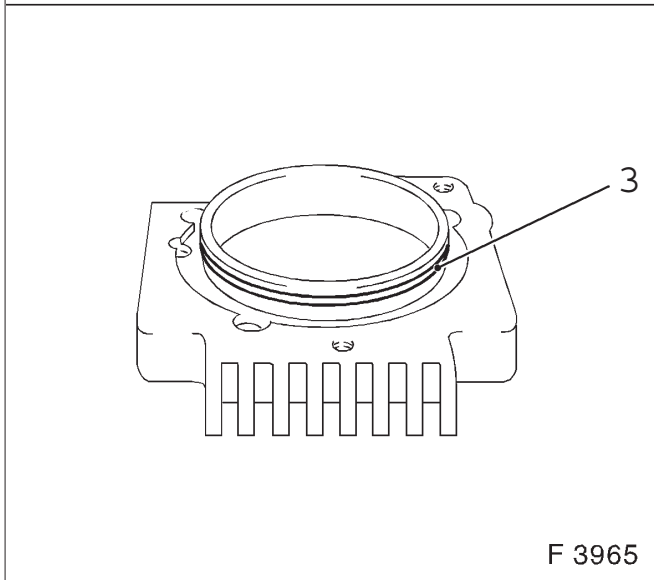
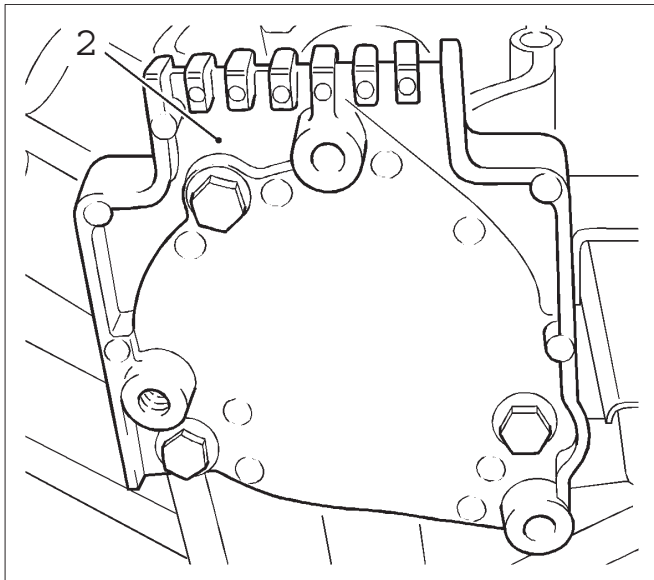

Exhaust Manifold, Remove and Install**Remove, Disconnect**

Disconnect spark plug wires from all spark plugs.
Remove exhaust manifold (5) and gasket from cylinder head.

Clean

Clean sealing surfaces and remove gasket remnants.

Install, Connect

Attach exhaust manifold with new gasket and new nuts to cylinder head – tightening torque 22 Nm / 16 lbf. ft.

Connect spark plug wires.

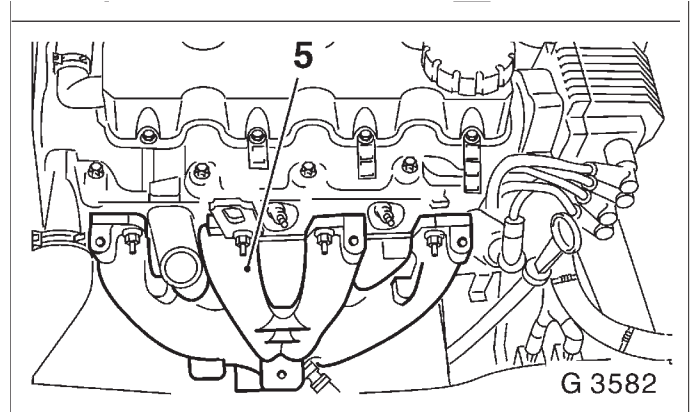

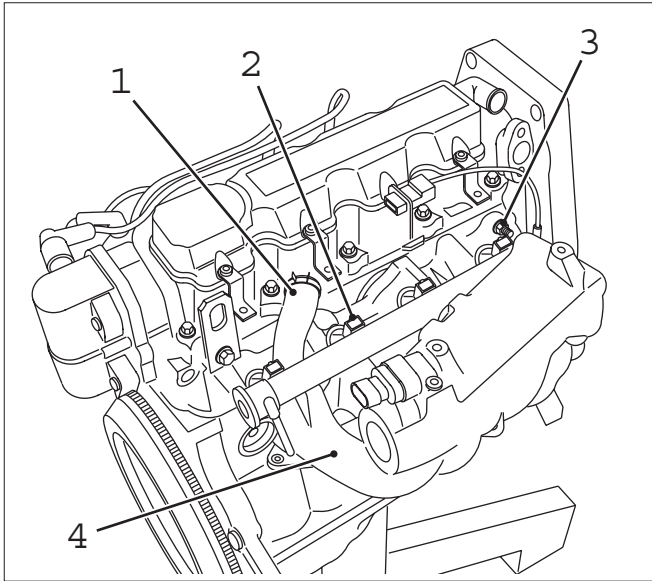

GMIGS178

Intake Manifold, Remove and Install

Important!

Fuel leak – observe safety regulations and national legislation. Reduce fuel pressure with Pressure Tester KM-J-34730-91 via testing port – collect escaping fuel in suitable container.

Remove, Disconnect

Disconnect ground cable from battery.

Open coolant drain bolt – collect escaping coolant.

Drain cooling system.

Remove engine vent hoses and from camshaft housing cover. Remove coolant hose from intake (1).

Remove air cleaner housing and air intake hose.

Remove fuel lines and harness from fuel injectors (2).

Remove intake manifold nuts (3).

Remove intake manifold and gasket (4).

Clean

Clean sealing surfaces and remove gasket remnants.

Install, Connect

Attach inlet manifold with new gasket to cylinder head – tightening torque 22 Nm / 16 lbf. ft.

Attach fuel lines.

Attach coolant hose to intake manifold.

Connect wiring harness plug to injectors.

Install, Connect

Install air cleaner housing with air intake hose.

Attach engine vent hoses to camshaft housing cover.

Close coolant drain bolt. Connect ground cable to battery.

Refill cooling system and purge air from system.

Camshaft and Cam Follower, Remove and Install
(Cylinder Head Installed)

Remove, Disconnect

Remove air cleaner housing with air intake cover.

Remove upper part of toothed belt cover – see operation "Toothed Belt Cover – Upper Part, Remove and Install".

Remove ribbed V-belts – see operation "Ribbed V-belts, Remove and Install".

Remove ribbed V-belt tensioner – see operation "Ribbed V-belt Tensioner, Remove and Install".

Remove lower part of toothed belt cover – see operation "Toothed Belt Cover – Lower Part, Remove and Install".

Important!

Before dismantling the toothed belt – screw fastening bolt for toothed belt drive gear into crankshaft and move crankshaft in engine rotational direction by 60° (dimension I) to before TDC mark.

Remove, Disconnect

Move toothed belt tension roller upward against spring force until bore holes align. Fix toothed belt tension roller in place with suitable drift (1).

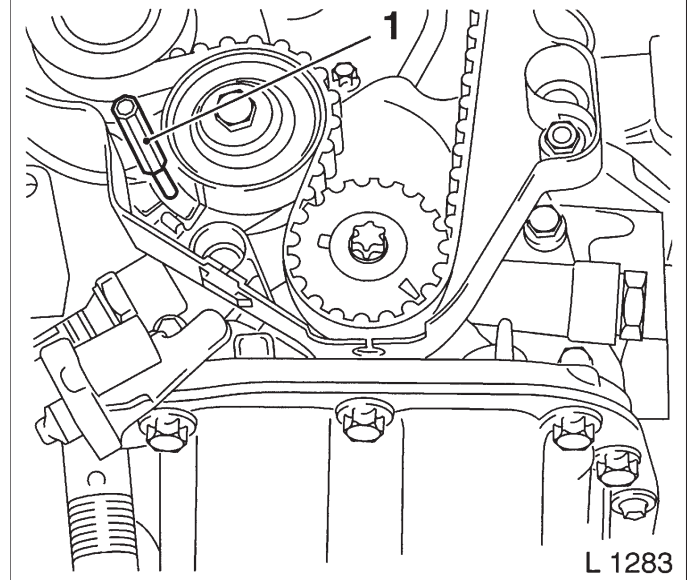
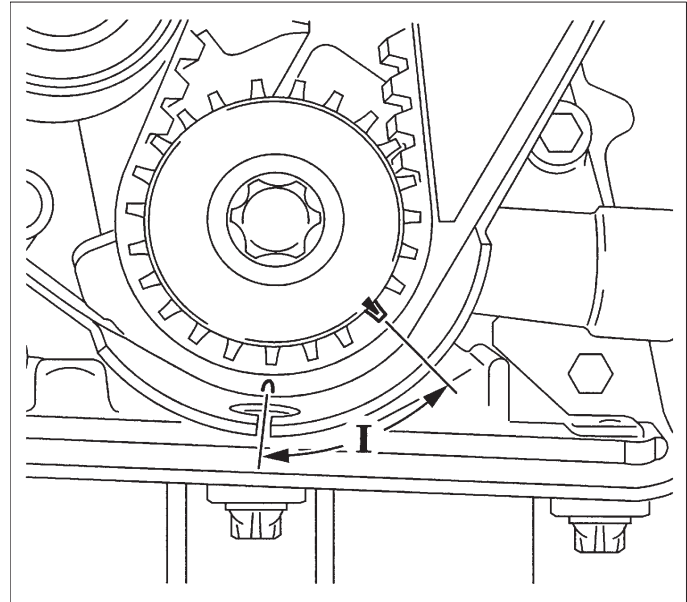

L 1283

Remove, Disconnect

Remove toothed belt from camshaft sprocket.
 Remove camshaft sprocket – see operation "Seal Ring in Front Camshaft Housing, Replace".
 Remove DIS ignition module – see operation "DIS Ignition Module, Remove and Install".
 Remove carrier plate from camshaft housing – see operation "Seal Ring in Rear Camshaft Housing, Replace".
 Remove pressure plate (1) from camshaft housing.

Important!

Cover oil return bore holes in cylinder head during assembly so thrust pieces cannot fall in.

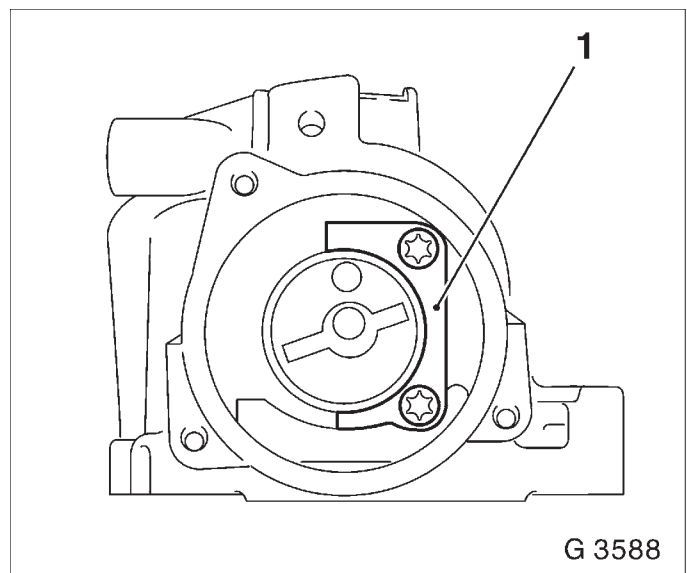

G 3588

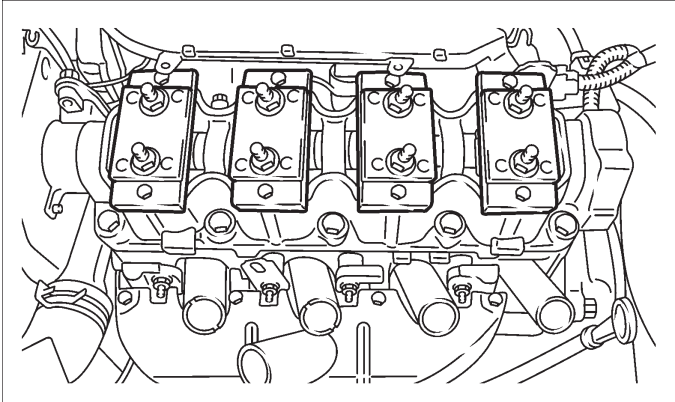

Remove, Disconnect

Attach Valve Lifter Depressor MKM-891 to camshaft housing.

Uniformly compress all cam followers. Pull camshaft (1) out of camshaft housing. Release valve lifter depressor and remove from camshaft housing. Remove cam followers and thrust pieces – lay aside in installation position and note layout.

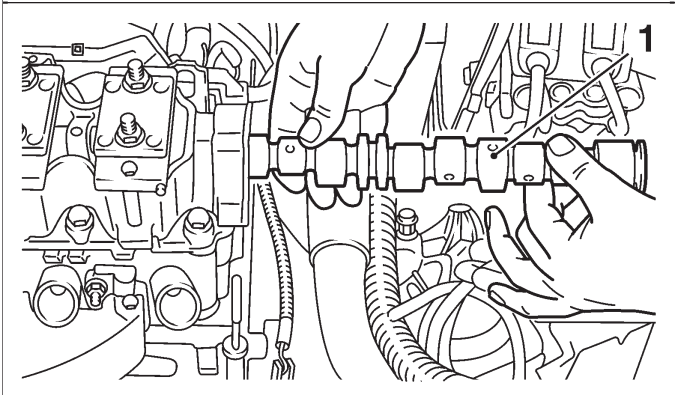

Inspect

Check all parts for damage and wear and replace if necessary. When replacing camshaft all cam followers must be replaced. Prior to installation ensure that crankshaft is 60° before TDC mark.

Install, Connect

Insert thrust pieces and cam followers – note installation position and allocation.

Attach valve lifter depressor onto camshaft housing and press down all cam followers uniformly. Coat sliding surfaces with MoS2 lubricating paste (grey). Insert camshaft in camshaft housing.

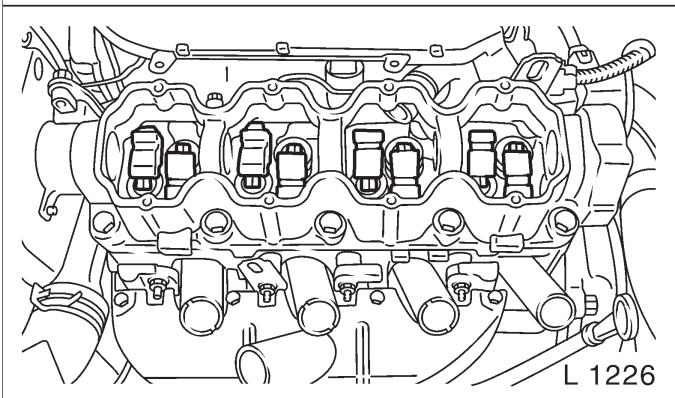

Install, Connect

Install pressure plate on camshaft housing – 8 Nm / 6 lbf. ft.

Remove, Disconnect

Release tension in valve lifter depressor and remove from camshaft housing.

Install, Connect

Attach carrier plate to camshaft housing – see operation "Seal Ring in Rear Camshaft Housing, Replace".

Attach DIS ignition module – see operation "DIS Ignition Module, Remove and Install".

Install camshaft sprocket – see operation "Seal Ring in Front Camshaft Housing, Replace".

Important!

Prior to installation of toothed belt, marks on toothed belt drive gear and oil pump housing, as well as notches on camshaft sprocket and rear toothed belt cover, must align – see operation "Timing, Adjust".

Install, Connect

Install toothed belt – see operation "Toothed Belt, Remove and Install".

Remove fastening bolt from toothed belt drive gear and install toothed belt cover, lower part – see operation "Toothed Belt Cover, Lower Part, Remove and Install".

Install ribbed V-belt tensioner – see operation "Ribbed V-belt Tensioner, Remove and Install".

Install ribbed V-belt – see operation "Ribbed V-belt, Remove and Install".

Install upper part of toothed belt cover – see operation "Toothed Belt Cover – Upper Part, Remove and Install".

Install air cleaner housing with air intake cover.

Hydraulic Valve Lifter, Replace (Cylinder Head Installed)**Remove, Disconnect**

Remove air intake cover.

Detach engine vent hose from camshaft housing cover.

Detach wiring trough from camshaft housing cover.

Remove camshaft housing cover from camshaft housing.

Adjust

At fastening bolt of toothed belt drive gear, turn crankshaft in engine rotational direction until cam (1) of hydraulic valve lifter to be replaced assumes a vertical position.

Remove, Disconnect

Place KM-565-A (2) on camshaft housing and valve head and tension valve spring. Remove cam follower (3) from camshaft housing – note thrust piece. Remove hydraulic valve lifter from camshaft housing.

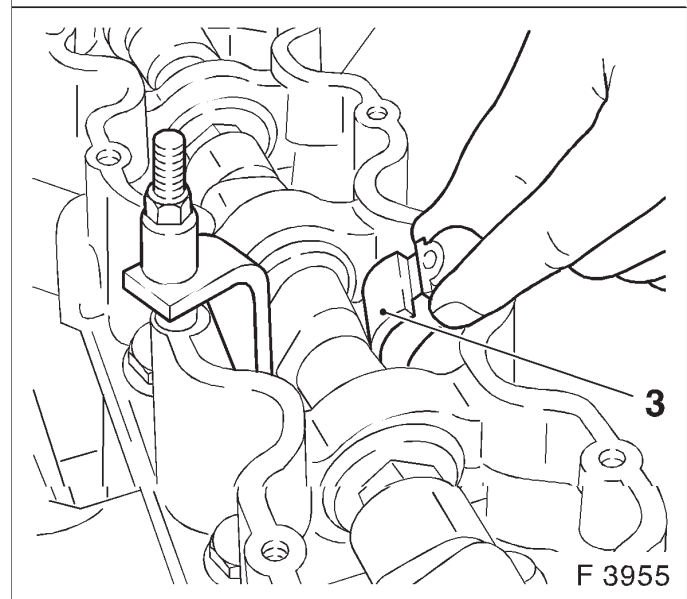
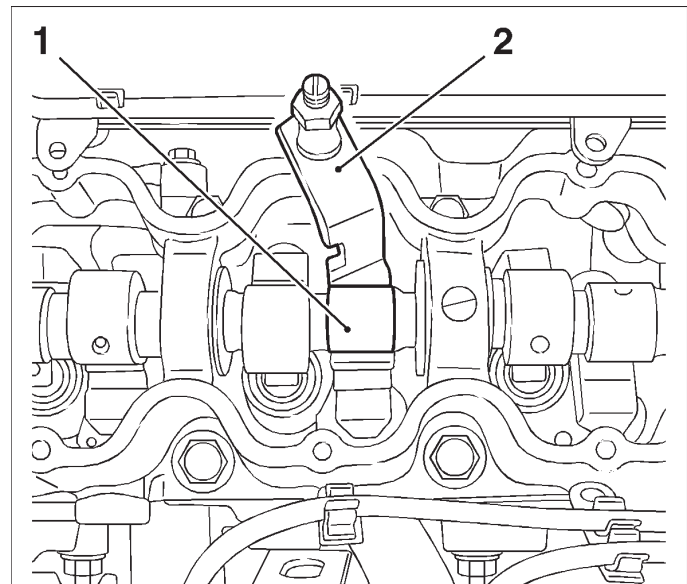

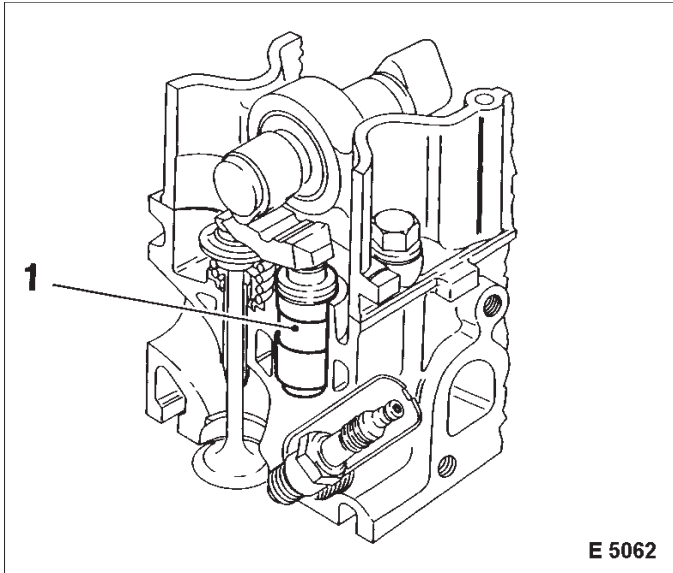

Install, Connect

Insert hydraulic valve lifter (1) in camshaft housing. Coat sliding surfaces of the rocker arm with MoS2 lubricating paste (grey) and insert in camshaft housing – note thrust piece.

Adjust

Adjustment of the hydraulic valve lifter is no longer required, as pre-tensioning has been taken into account in design.

Install, Connect

Release valve spring and remove KM-565-A. Install camshaft housing cover at camshaft housing – tightening torque 8 Nm / 6 lbf. ft. Attach wiring trough to camshaft housing cover – tightening torque 8 Nm / 6 lbf. ft. Attach engine bleeding hose to camshaft housing cover.

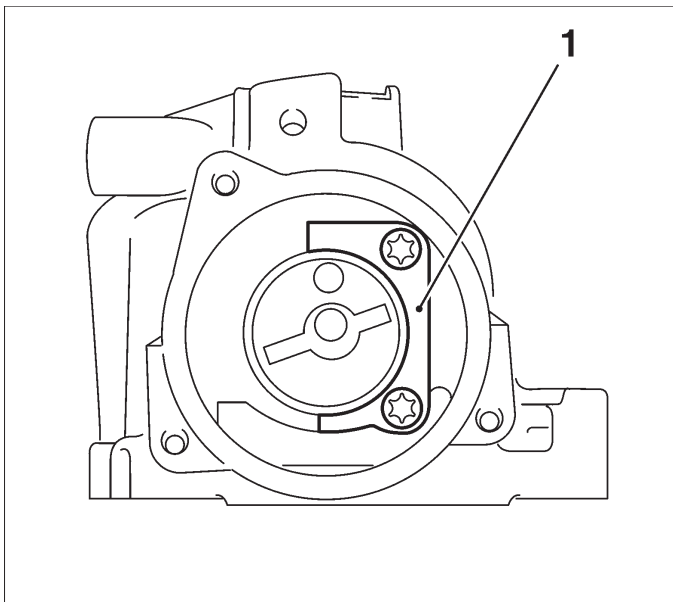

Camshaft, Remove and Install (Cylinder Head Removed)

Remove, Disconnect

Remove DIS ignition module – see operation "DIS Ignition Module, Remove and Install". Remove carrier plate from camshaft housing – see operation "Seal Ring in Rear Camshaft Housing, Replace". Remove pressure plate (1) from camshaft housing. Remove camshaft from camshaft housing. Edge front seal ring out of camshaft housing.

Clean

Clean sealing surfaces and remove gasket remnants.

Inspect

Check camshaft housing for damage and wear – see operation "Camshaft Housing for Plane Surface, Check". When replacing camshaft, always replace all cam followers.

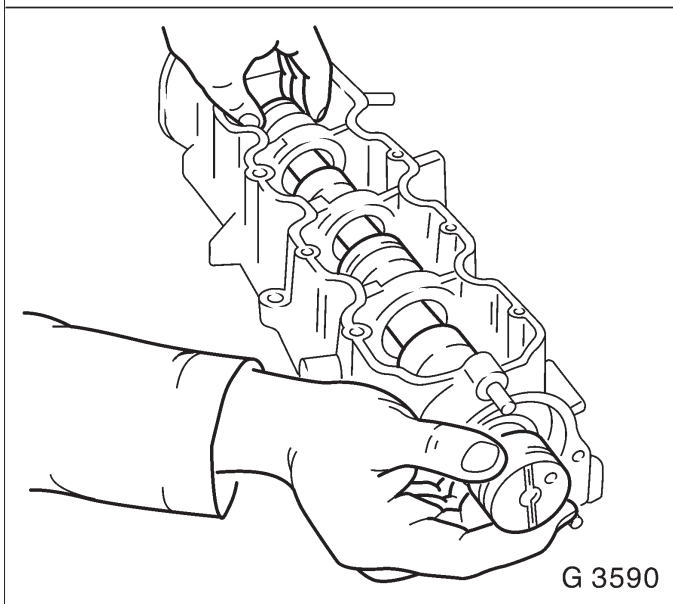

Install, Connect

Coat sliding surfaces of the camshaft with MoS₂ lubricating paste (grey), insert camshaft in camshaft housing.

Install pressure plate on camshaft housing – 8 Nm / 6 lbf. ft.

Lightly coat sealing lip of front seal ring with silicon grease (white). Install new front seal ring with KM-422 in camshaft housing – use bolt and washer of camshaft pulley.

Attach carrier plate to camshaft housing – see operation "Seal Ring in Rear Camshaft Housing, Replace".

Attach DIS ignition module – see operation "DIS Ignition Module, Remove and Install".

Camshaft Housing, Replace**Remove, Disconnect**

Remove air cleaner housing with air intake cover.

Remove upper part of toothed belt cover – see operation "Toothed Belt Cover – Upper Part, Remove and Install".

Remove ribbed V-belts – see operation "Ribbed V-belts, Remove and Install".

Remove ribbed V-belt tensioner – see operation "Ribbed V-belt Tensioner, Remove and Install".

Remove lower part of toothed belt cover – see operation "Toothed Belt Cover – Lower Part, Remove and Install".

Remove toothed belt – see operation "Toothed Belt, Remove and Install".

Remove toothed belt tension roller – see operation "Toothed Belt Tension Roller, Remove and Install".

Rear toothed belt cover – see operation "Toothed Belt Cover – Rear, Remove and Install".

Detach or disconnect all wiring harness plugs, ground connections and hose connections from intake manifold "Intake Manifold, Remove and Install".

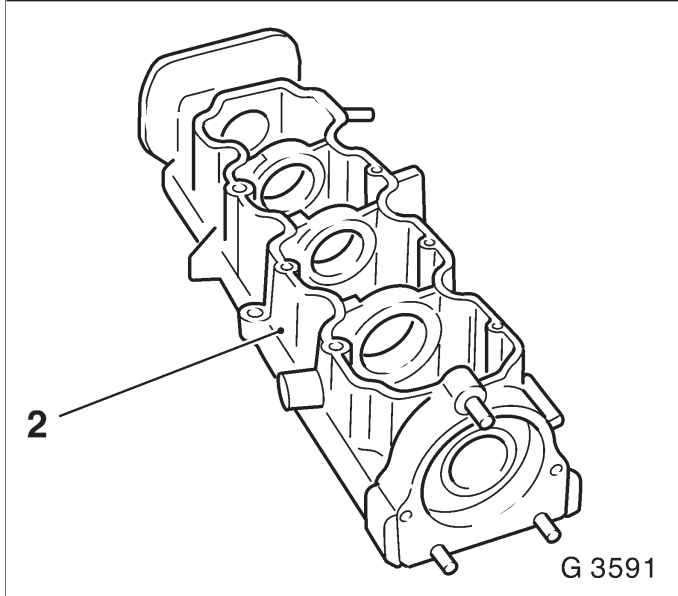
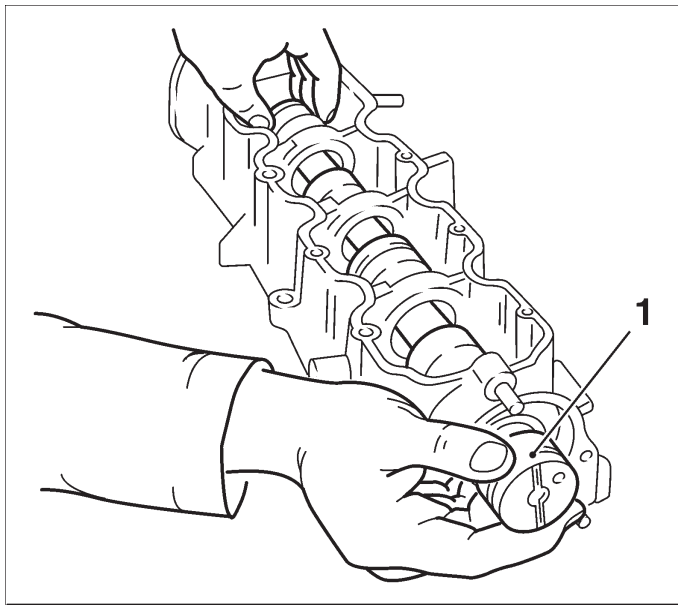

G 3591

Remove, Disconnect

Remove cylinder head – see operation "Cylinder Head, Remove and Install".

Remove DIS ignition module – see operation "DIS Ignition Module, Remove and Install".

Remove carrier plate – see operation "Seal Ring in Rear Camshaft Housing, Replace".

Remove camshaft (1) – see operation "Camshaft, Remove and Install (Cylinder Head Removed)".

Clean

Clean sealing surfaces and bore holes and remove sealant residues.

Inspect

Check camshaft housing (2) for plane surface – see operation "Camshaft Housing for Plane Surface, Check".

Install, Connect

Install camshaft – see operation "Camshaft, Remove and Install (Cylinder Head Removed)".

Install carrier plate – see operation "Seal Ring in Rear Camshaft Housing, Replace".

Install DIS ignition module – see operation "DIS Ignition Module, Remove and Install".

Install cylinder head – see operation "Cylinder Head, Remove and Install".

Attach or connect all wiring harness plugs, ground connections and hose connections to intake manifold – see operation "Intake Manifold, Remove and Install".

Install rear toothed belt cover – see operation "Toothed Belt Cover – Rear, Remove and Install".

Install toothed belt tension roller – see operation "Toothed Belt Tension Roller, Remove and Install".

Install toothed belt – see operation "Toothed Belt, Remove and Install".

Install lower part of toothed belt cover – see operation "Toothed Belt Cover – Lower Part, Remove and Install".

Install ribbed V-belt tensioner – see operation "Ribbed V-belt Tensioner, Remove and Install".

Install, Connect

Install ribbed V-belt – see operation "Ribbed V-belt, Remove and Install".

Install upper part of toothed belt cover – see operation "Toothed Belt Cover – Upper Part, Remove and Install".

Install air cleaner housing with air intake cover.

Camshaft Housing, Check for Plane Surface**Clean**

Clean sealing surfaces and remove gasket remnants.

Inspect

Check sealing surfaces in length and width for deformation and check for warping along the diagonals – use straight edge. If deformed or warped, replace camshaft housing.

Measure

Height of camshaft housing (sealing surface to sealing surface).

Dimension I: 66.5 mm

Cylinder Head, Remove and Install**Important!**

Remove cylinder head only with cold engine (room temperature).

Remove, Disconnect

Detach battery ground cable.

Open coolant drain bolt – collect escaping coolant.

Remove air cleaner housing with air intake cover.

Remove engine vacuum hose (1) from camshaft housing cover.

Remove upper part of toothed belt cover – see operation "Toothed Belt Cover – Upper Part, Remove and Install".

Remove ribbed V-belts – see operation "Ribbed V-belts, Remove and Install".

Detach alternator support (3) from alternator and intake manifold. Release alternator from alternator shackle (2) and swing alternator rearwards.

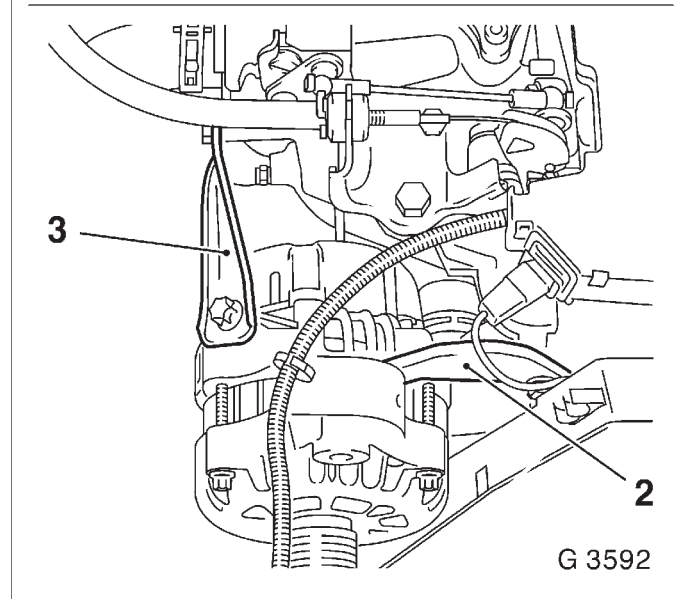
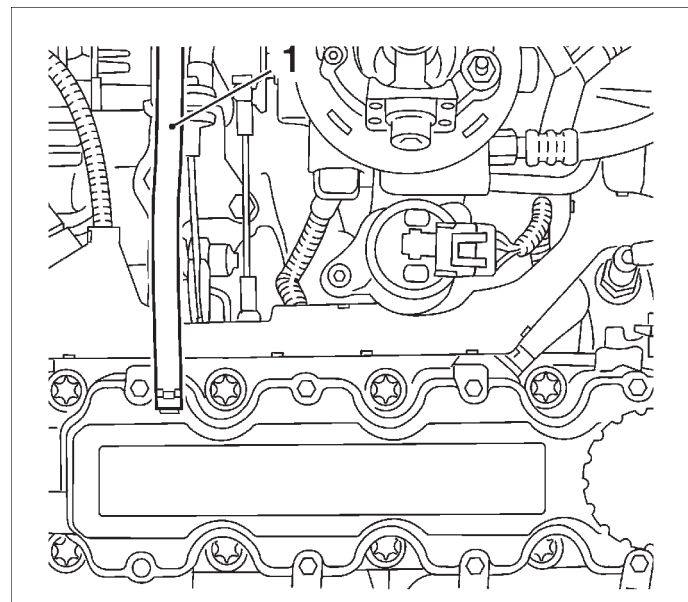
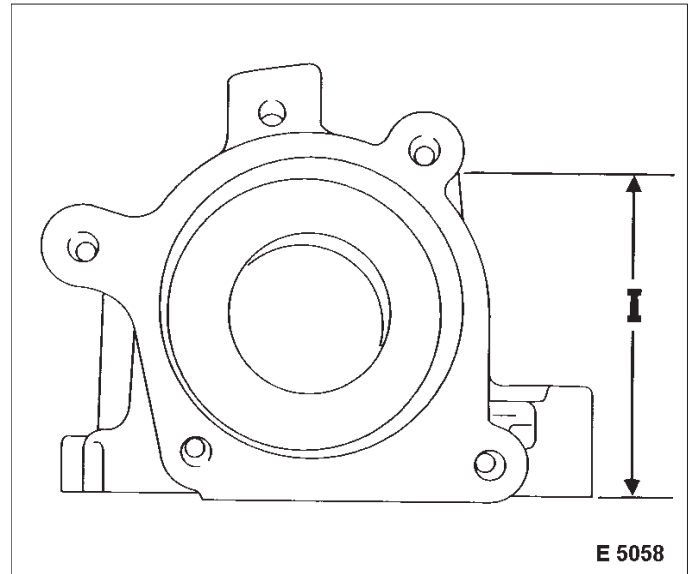

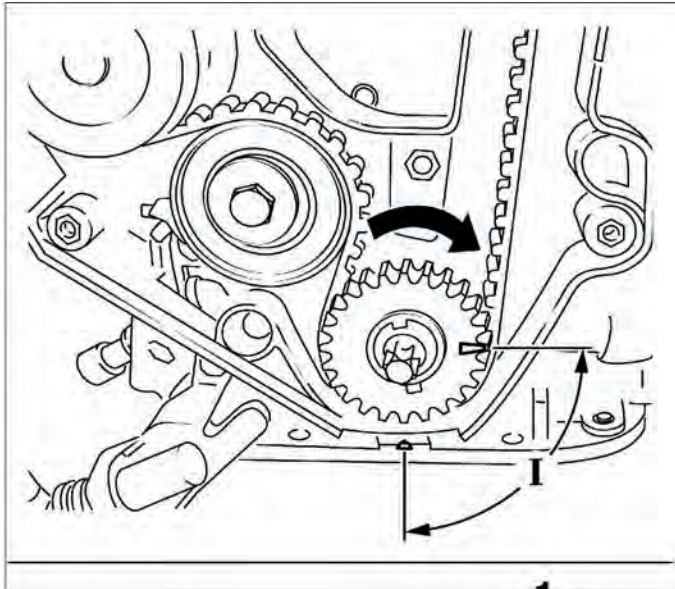

Remove, Disconnect

Remove ribbed V-belt tensioner – see operation "Ribbed V-belt Tensioner, Remove and Install".

Remove lower part of toothed belt cover – see operation "Toothed Belt Cover – Lower Part, Remove and Install".

Screw fastening bolt for toothed belt drive gear into crankshaft and move crankshaft in engine rotational direction by 90° (dimension I) to before TDC mark.

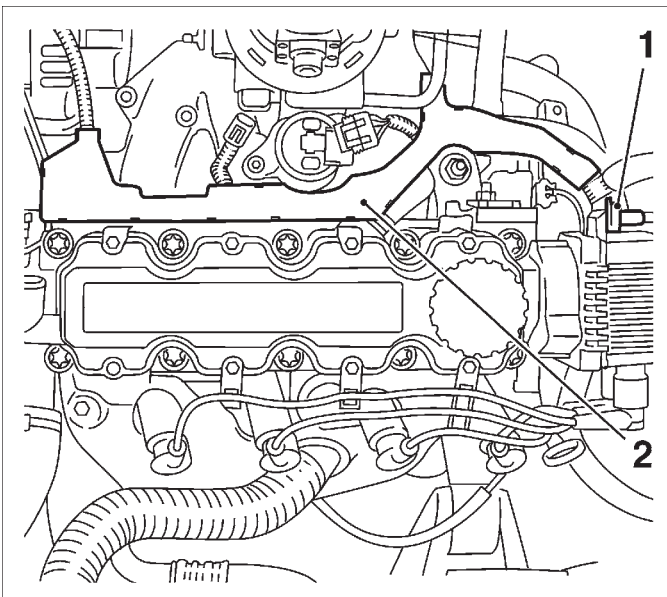

Remove, Disconnect

Detach or disconnect all wiring harness plugs, ground connections and hose connections from intake manifold – see operation "Intake Manifold, Remove and Install".

Detach wiring harness plug (1) from DIS ignition module and expose wiring harness.

Detach wiring trough (2) from camshaft housing cover and lay aside.

Detach engine vent hose (3) from camshaft housing and engine vent flange and remove.

Remove coolant hose (6) from thermostat housing.

Disconnect spark plug connectors.

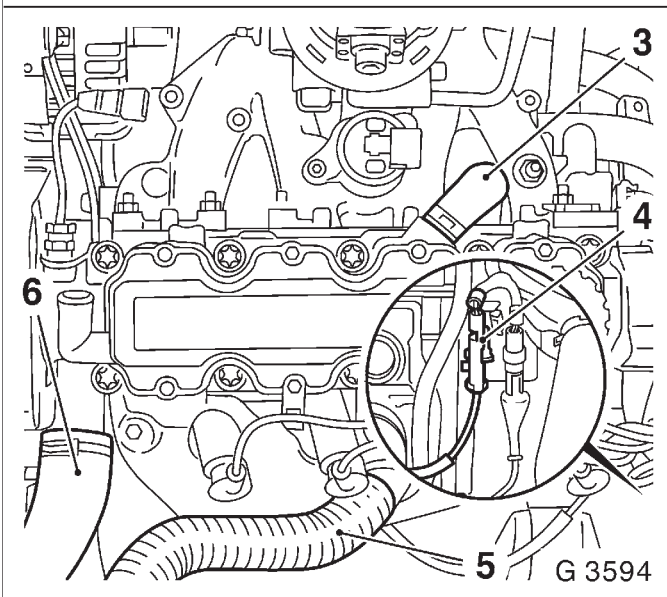

Remove, Disconnect

Move toothed belt tension roller upwards against spring force until bore holes align. Fix toothed belt tension roller in place with suitable drift (2).

Mark running direction (front edge) of the toothed belt for identification and remove toothed belt.

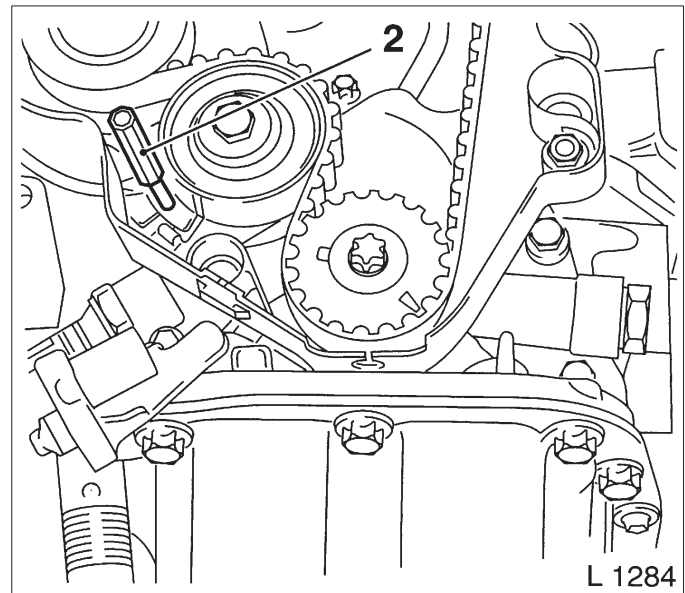

Remove, Disconnect

Remove toothed belt tension roller (4) from oil pump.

Remove toothed belt drive gear (3) from crankshaft.

Remove engine damping block main bracket (2) from cylinder block.

Remove camshaft housing cover from camshaft housing.

Remove camshaft sprocket (1) – hold with open-ended wrench on hex of camshaft.

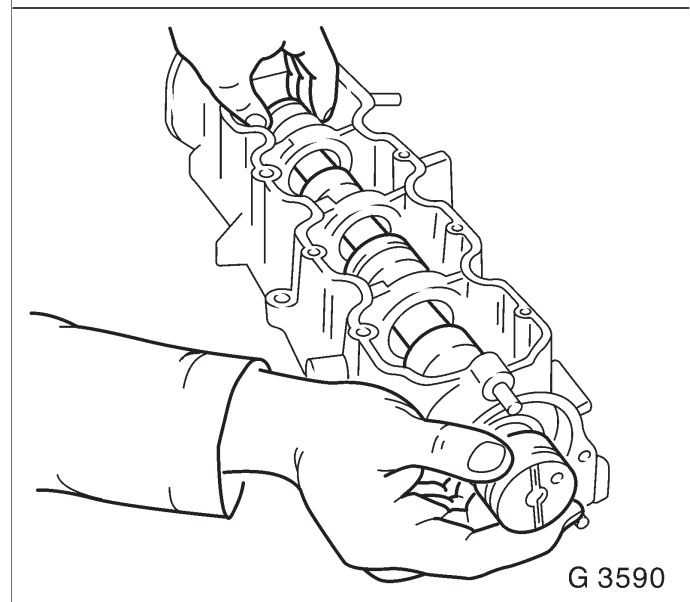
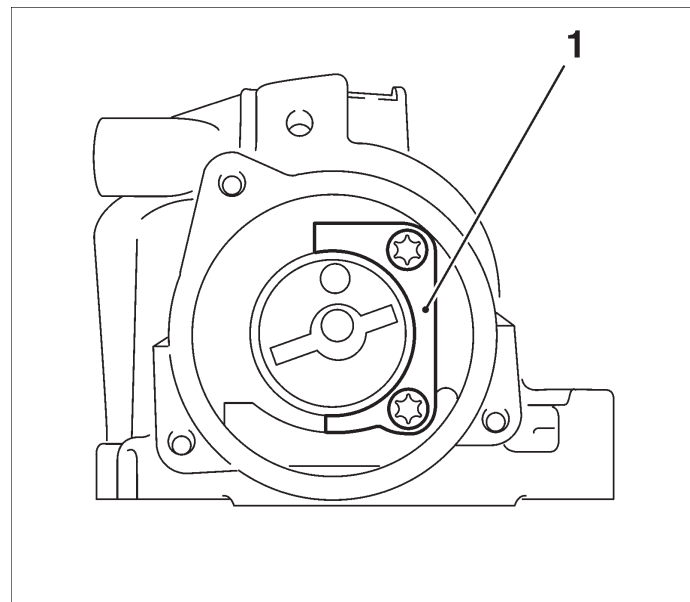

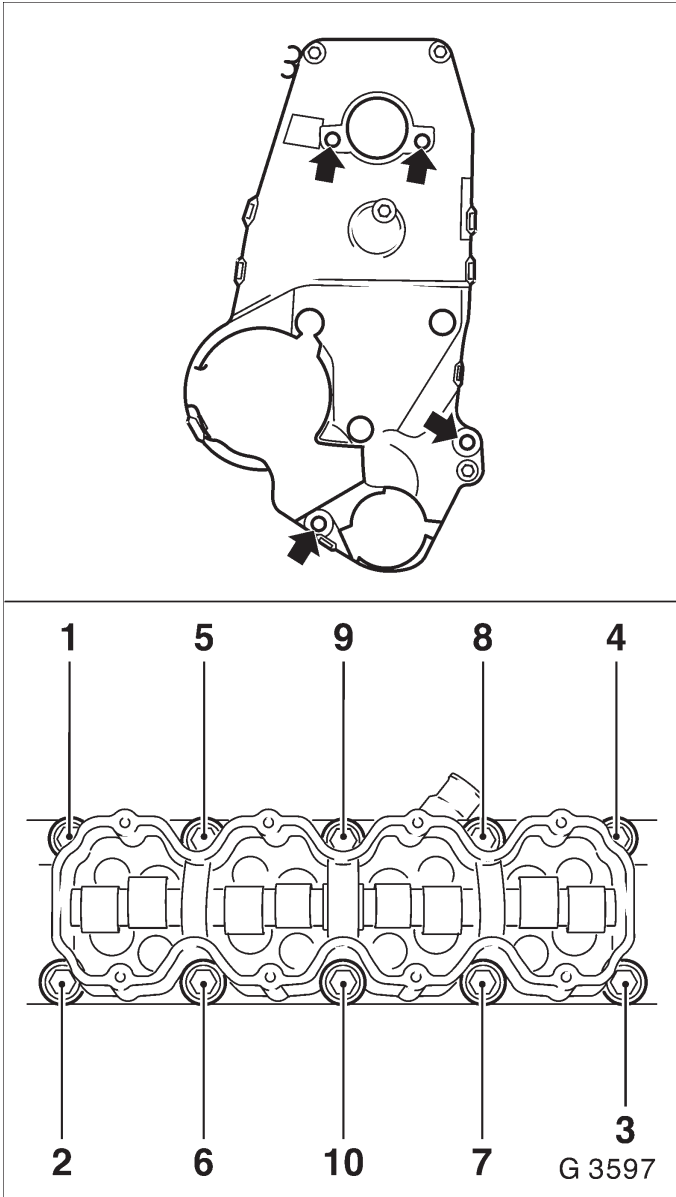

Remove, Disconnect

Remove rear part of toothed belt cover (arrow) from oil pump and camshaft housing.

Detach cylinder head bolts in sequence shown. Remove camshaft housing from cylinder head. Remove cam followers, thrust pieces and hydraulic valve lifter – note location of each piece for reassembly in the same location. Remove cylinder head and gasket from cylinder block.

Clean

Clean sealing surfaces, bore holes and thread of cylinder head bolts.

Inspect

Check cylinder head and cylinder block for plane surface – see operations "Cylinder Head, Check for Plane Surface" and "Cylinder Block, Check for Plane Surface".

Install, Connect

Install cylinder head gasket – mark "OBEN/TOP" on top and towards timing side of engine.

Place cylinder head on cylinder block. Insert hydraulic valve lifters, thrust pieces and cam followers with MoS₂ paste (grey) – note allocation.

Apply a bead of surface sealant (green) to sealing surfaces of cylinder head.

Place camshaft housing on cylinder head.

Tighten cylinder head bolts in order shown – use torque wrench and KM-470-B.

Attach cylinder head and camshaft housing with new cylinder head bolts to cylinder block – tightening torque 25 Nm / 18 lbf. ft. + 60° + 60° + 60°.

Attach rear toothed belt cover to oil pump and camshaft housing – tightening torque 6 Nm / 4 lbf. ft.

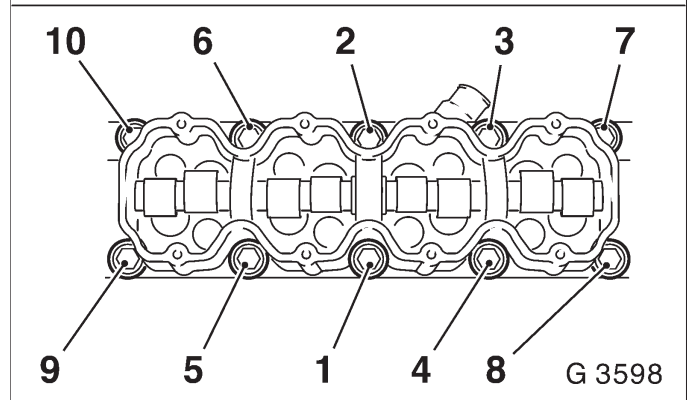
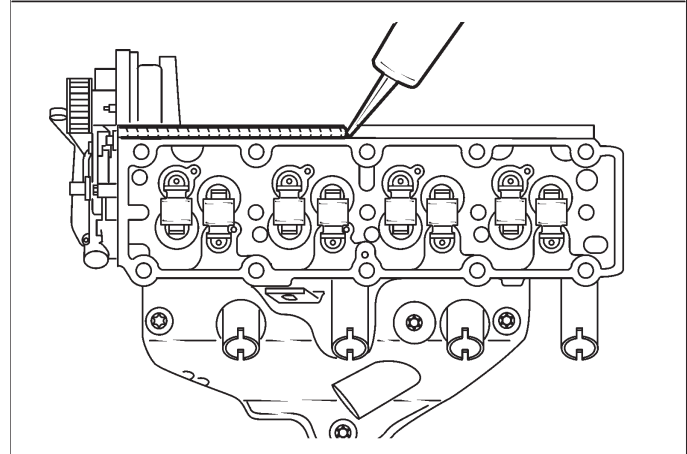
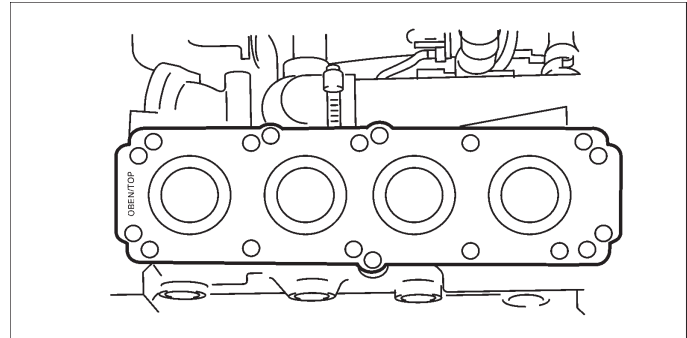
**Install, Connect**

Attach camshaft sprocket to camshaft – hold with open-ended wrench on hex of camshaft – tightening torque 45 Nm / 33 lbf. ft.

Install camshaft housing cover at camshaft housing – tightening torque 8 Nm / 6 lbf. ft.

Attach engine damping block support to cylinder block – tightening torque 50 Nm / 37 lbf. ft.

Slide toothed belt drive gear onto crankshaft journal – note installation position.

Attach toothed belt tension roller to oil pump – tightening torque 20 Nm / 15 lbf. ft.

Install toothed belt – ensure that tensioned side (I) is taut.

Note timing marks! – see operation "Timing, Adjust".

Adjust toothed belt tension – see operation "Toothed Belt Tension, Adjust".

Attach engine damping block to right of side member – tightening torque 35 Nm / 26 lbf. ft.

Attach engine damping block bracket to auxiliary engine damping blocks support – tightening torque 55 Nm / 41 lbf. ft.

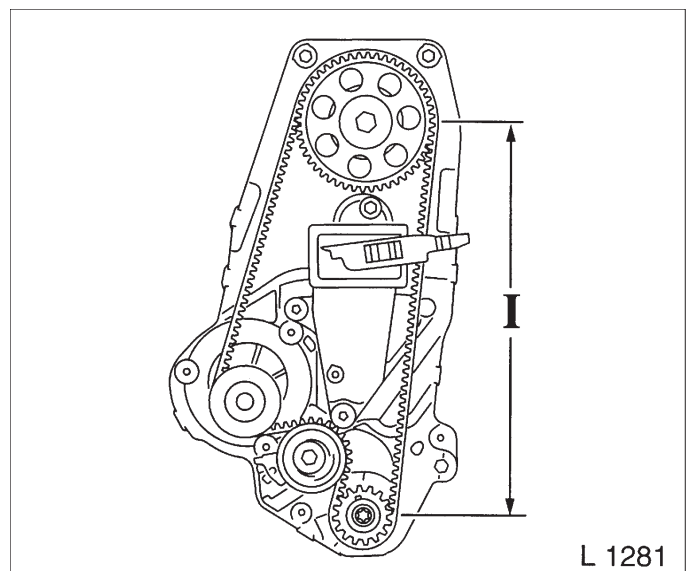

Install, Connect

Install lower part of toothed belt cover – see operation "Toothed Belt Cover – Lower Part, Remove and Install".

Install ribbed V–belt tensioner – see operation "Ribbed V–belt Tensioner, Remove and Install".

Connect spark plug connectors to spark plugs.

Attach coolant hose to thermostat housing.

Attach engine vent hose to camshaft housing and engine vent flange.

Install, Connect

Close coolant drain bolt.

Attach alternator to alternator shackle – tightening torque 20 Nm / 15 lbf. ft.

Attach alternator support to alternator and intake manifold – tightening torque 20 Nm / 15 lbf. ft.

Install ribbed V–belt – see operation "Ribbed V–belt, Remove and Install".

Install upper part of toothed belt cover – see operation "Toothed Belt Cover – Upper Part, Remove and Install".

Install air cleaner housing with air intake cover.

Connect ground cable to battery.

Install, Connect

Connect wiring harness plug to DIS ignition module – note cable routing.

Attach engine vacuum hose to camshaft housing cover.

Attach or connect all wiring harness plugs, ground connections and hose connections to intake manifold – see operation "Intake Manifold, Remove and Install".

Install, Connect

For version with hex bolts: Attach front exhaust pipe with new gasket and bolts coated with assembly paste (white) to exhaust manifold – tightening torque 35 Nm / 26 lbf. ft.

For version with hex nuts: Attach front exhaust pipe with new gasket and new nuts to exhaust manifold – tightening torque 45 Nm / 33 lbf. ft.

Cylinder Head, Check for Plane Surface

Clean

Clean sealing surface and remove sealant remnants.

Inspect

Check length and width of cylinder head sealing surfaces for deformation and diagonals for warpage – use straight edge.

Important!

Resurfacing of the cylinder head is not permitted.

Measure

Height of cylinder head (sealing surface to sealing surface)

Dimension I: 95.90 to 96.10 mm

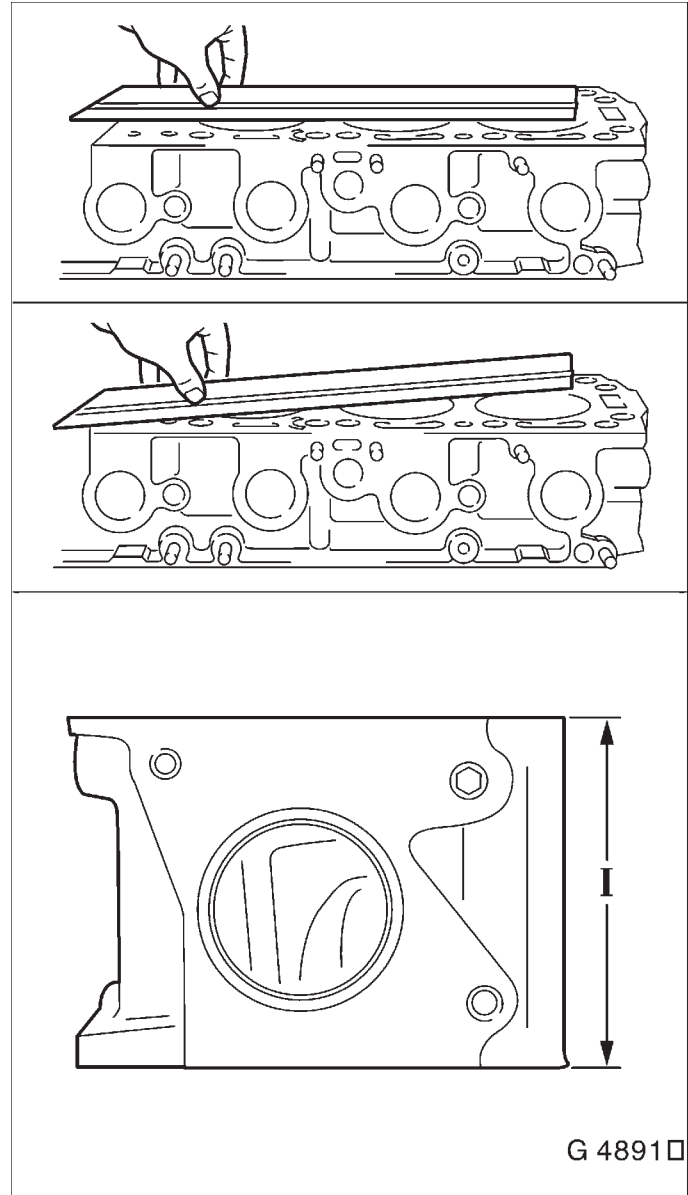

G 4891 □

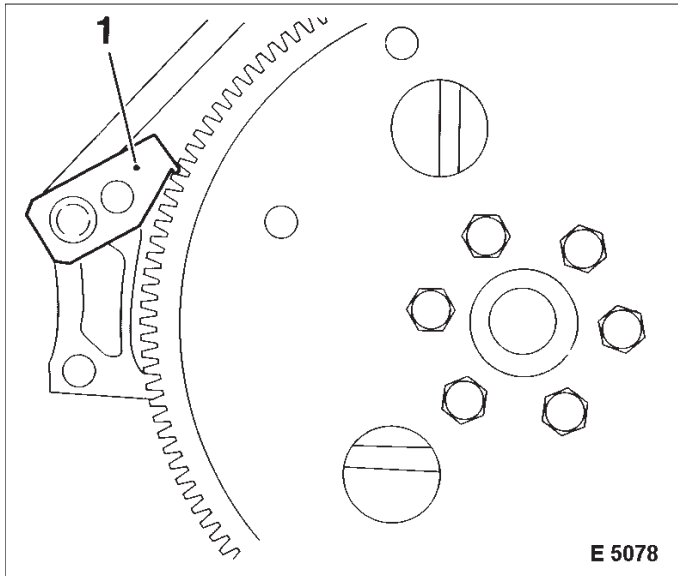

Flywheel/Flexplate, Remove and Install

Remove, Disconnect

Hold flywheel with KM-652 (1) and remove from crankshaft.

Install, Connect

Attach flywheel to crankshaft with new bolts
– tightening torque 35 Nm / 26 lbf. ft. + 30° + 15°
– lock flywheel with KM-652 (2).

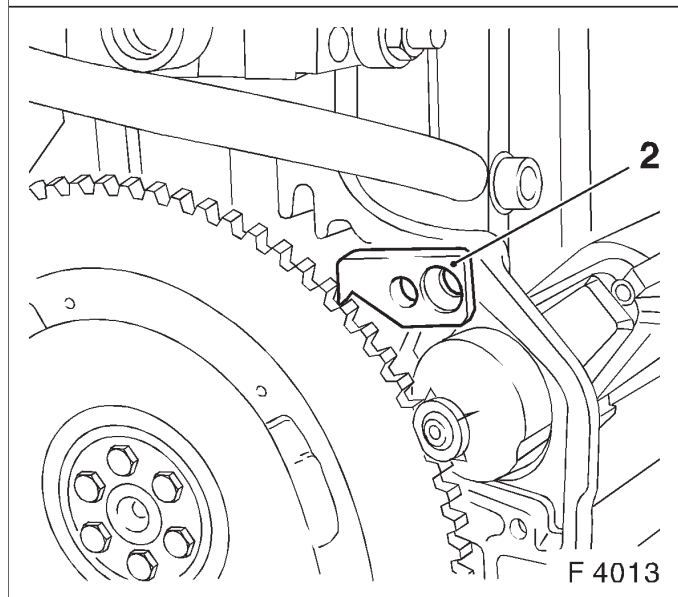
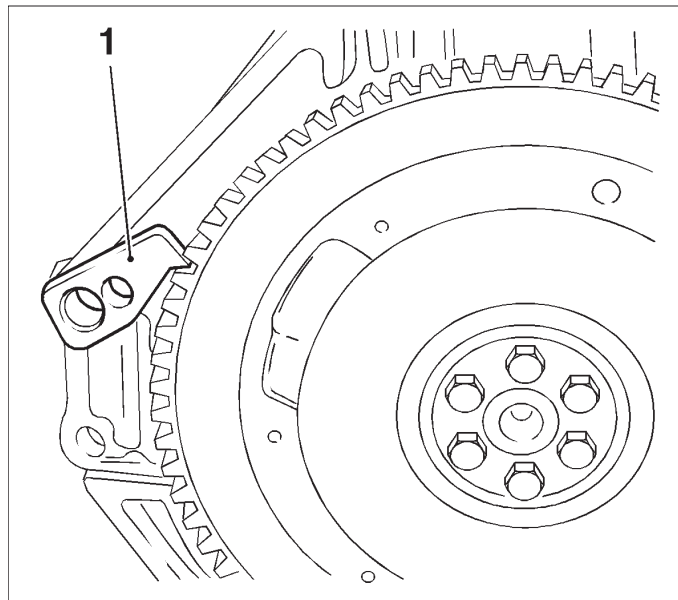

Seal Ring – Rear Crankshaft, Replace

Remove, Disconnect

Remove flywheel – see operation "Flywheel, Remove and Install".

Edge out seal ring (1) with suitable tool. Do not damage sealing surfaces.

Clean

Clean sealing surfaces and remove gasket remnants.

Install, Connect

Coat sealing lip of new seal ring with silicon grease (white) and position with sealed side on Protective Sleeve KM-658-2 (2).

Connect protective sleeve with attached seal ring to crankshaft journal and press in flush. Place Installer Sleeve KM-658-1 (3) on Protective Sleeve KM-658-2 (2) and drive in seal ring until it sits flush in housing.

Install flywheel – see operation "Flywheel, Remove and Install".

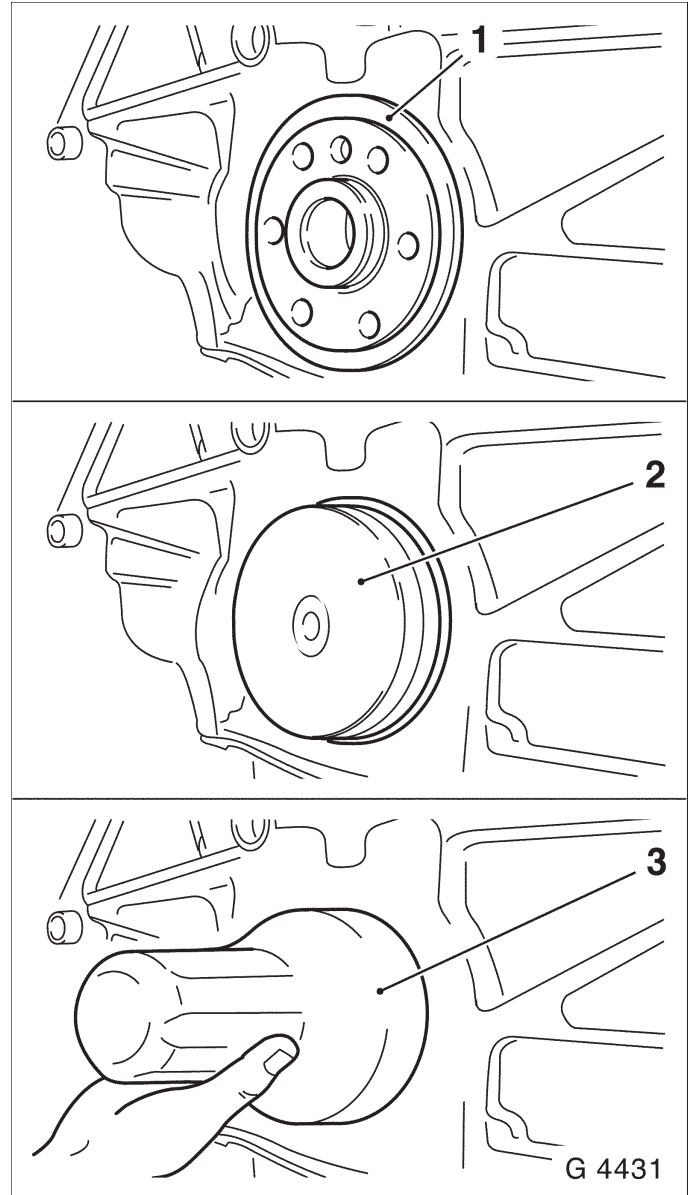

Piston with Con-rod, Remove and Install

Remove, Disconnect

Remove oil pan – see operation "Oil pan, Remove and Install". Remove cylinder head – see operation "Cylinder Head, Remove and Install".

Remove oil intake tube (1) from oil pump and cylinder block.

Important!

Mark order of con-rod bearing caps.

Remove con-rod bearing cap from con-rod.

The mating surfaces of the con-rod and the con-rod bearing caps form an individual fit and as a result must not be damaged or replaced under any circumstances.

Do not lay con-rod and con-rod bearing caps on mating surfaces in order to avoid damage.

Remove combustion residue from upper part of cylinder bore.

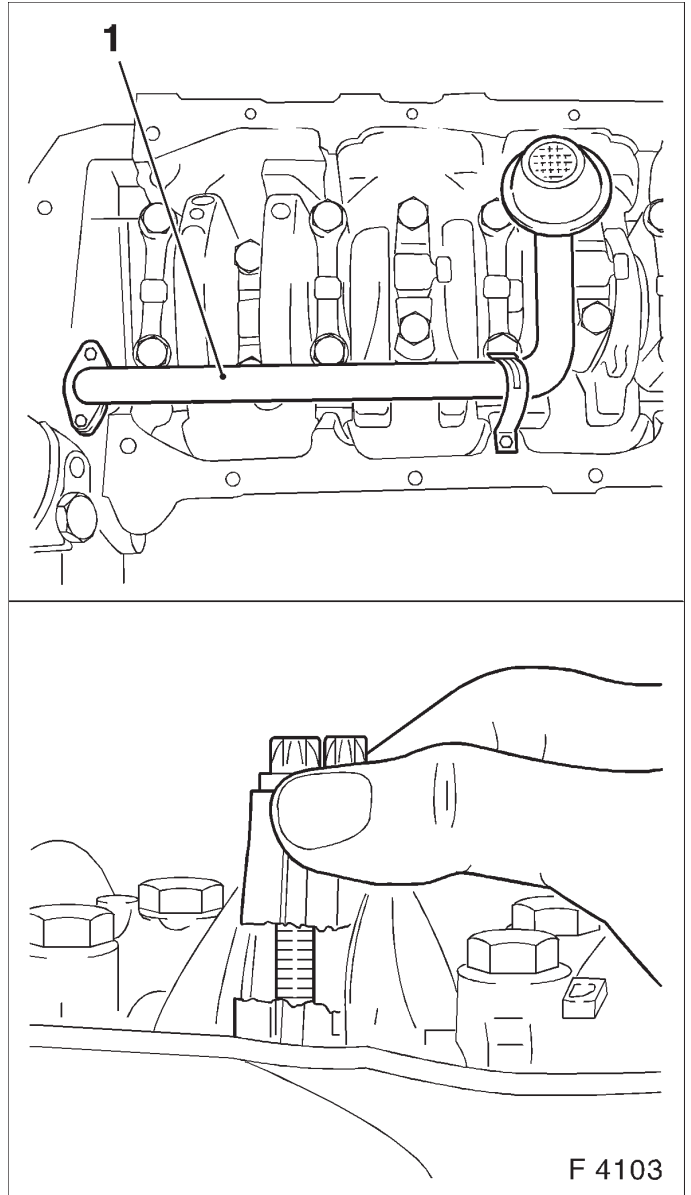

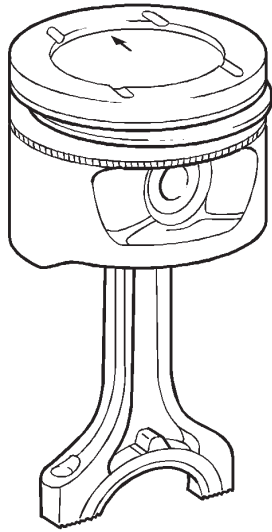

Remove, Disconnect

Push piston with con-rod upwards from cylinder bore.

Clean

Inspect

Check all parts, clean and if necessary, replace. Replace piston – see operation "Piston, Replace".

Adjust

Before inserting con-rod journal of crankshaft, set to BDC position and coat with engine oil.

Adjust piston ring gaps:

Oil scraper ring II: offset ring gaps of the steel band rings each 25 to 50 mm to the left or right of gap in intermediate ring. Piston rings I: offset ring gaps by approx. 120°. Second piston ring with identification "TOP" uppermost.

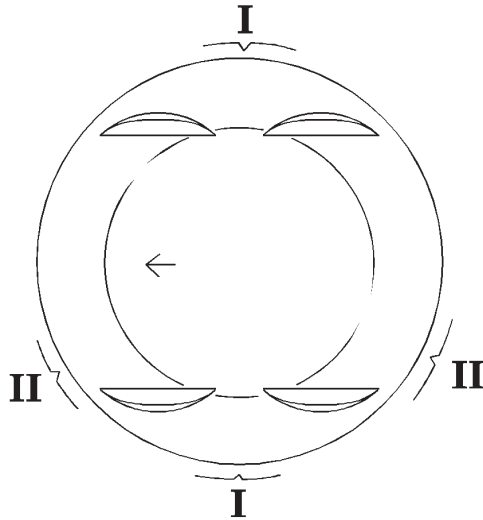

F 4104

Install, Connect

Coat piston rings with engine oil and compress with piston ring pliers.

Push piston into cylinder bore with hammer handle.

Important!

Note installation position of piston and con-rod.

Arrow (1) on piston head points to engine timing side, bead (2) on con-rod points to transmission side of engine.

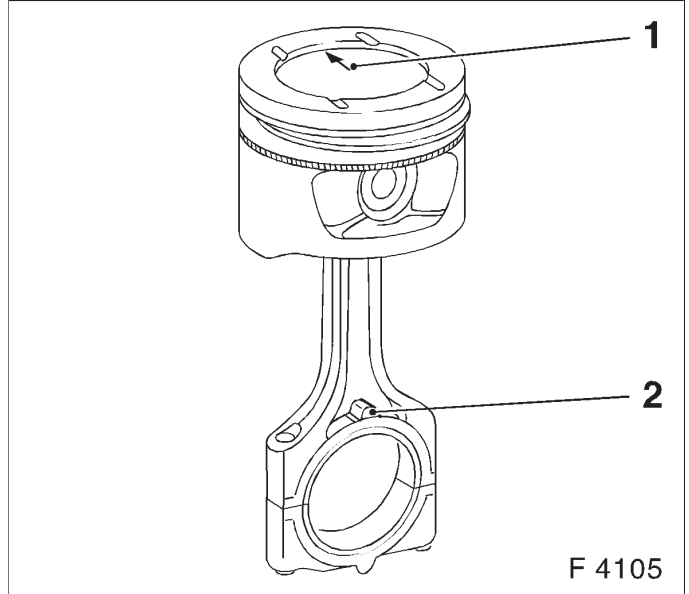
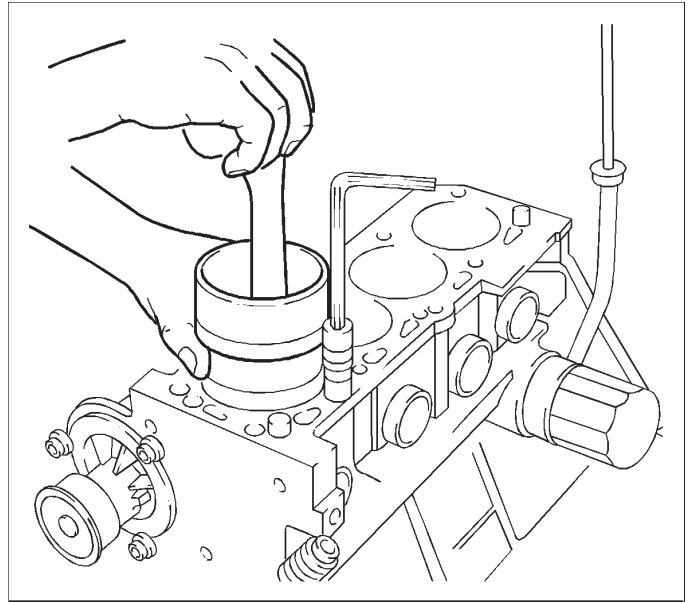

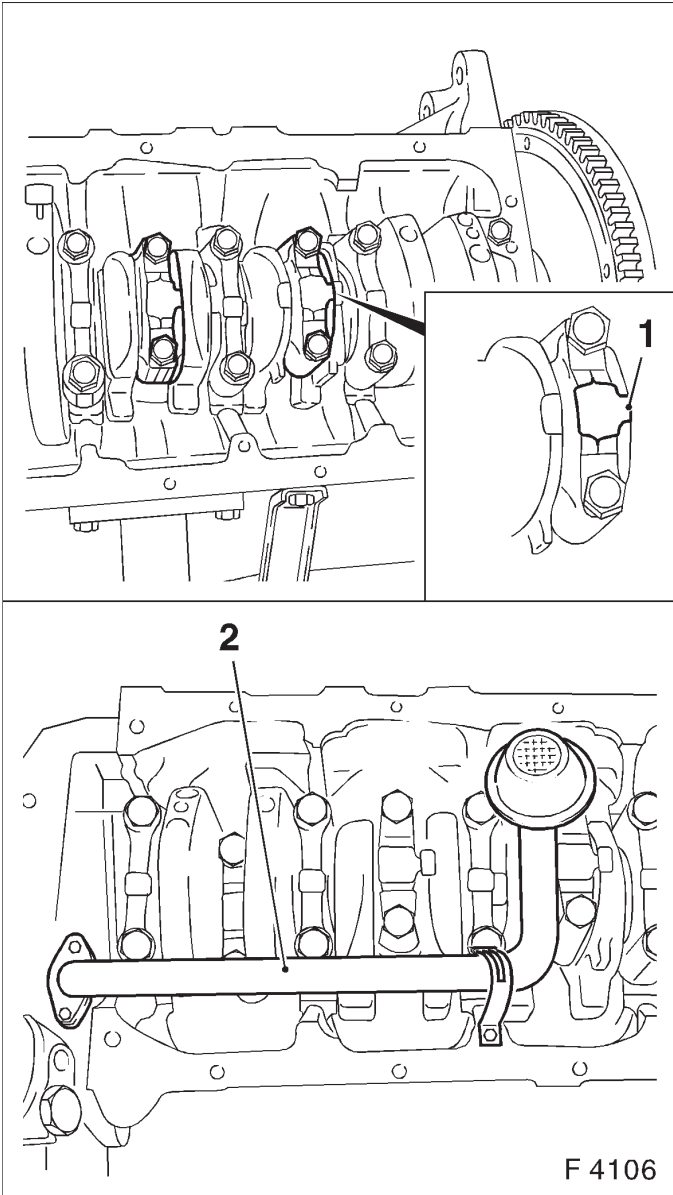

Install, Connect

Note sequence of con-rod bearing caps.

Install con-rod bearing cap – bead (1) of con-rod bearing caps points to transmission side.

Attach con-rod bearing cap to con-rod with new bolts – tightening torque 25 Nm / 18.5 lbf. ft. + 30°.

Attach oil intake pipe (2) with new seal ring to oil pump – 8 Nm / 6 lbf. ft.1).

Attach oil intake manifold to cylinder block – tightening torque 8 Nm / 6 lbf. ft.

Install cylinder head – see operation "Cylinder Head, Remove and Install".

Install oil pan – see operation "Oil Pan, Remove and Install".

1) Recut thread before reuse and insert bolts with screw locking compound (red). The installation time including the torque check is max. 10 min.

Piston Rings, Remove and Install

Remove, Disconnect

Remove piston with con-rod – see operation "Piston with Con-rod, Remove and Install".

Remove piston rings with piston ring pliers (1).

Clean

Clean piston ring grooves – use ground-down side of old piston ring.

Inspect

Check piston ring gap with feeler gauge by inserting piston ring at narrowest point of the cylinder bore.

Permissible ring gap:

Squared ring (2): 0.30-0.50 mm (0.011-0.020 in)

Tapered ring (3): 0.30 to 0.50 mm (0.011-0.020 in)

Oil scraper ring (4): 0.40 to 1.40 mm (0.015-0.055 in)

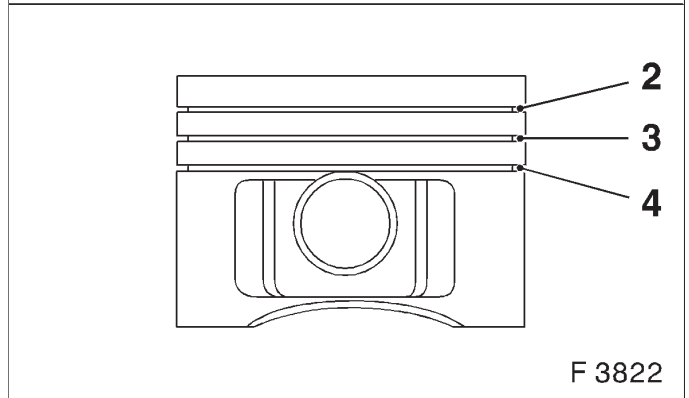
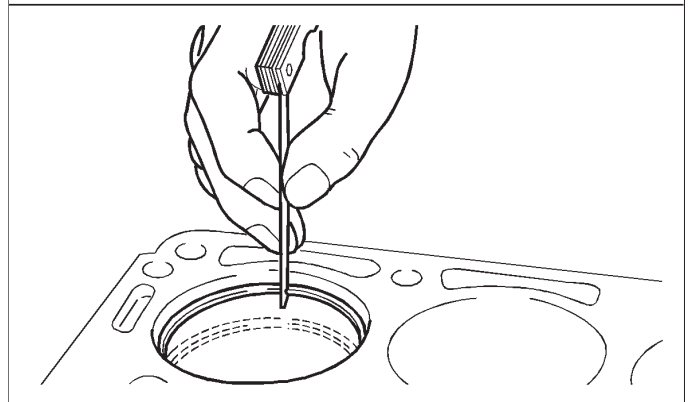
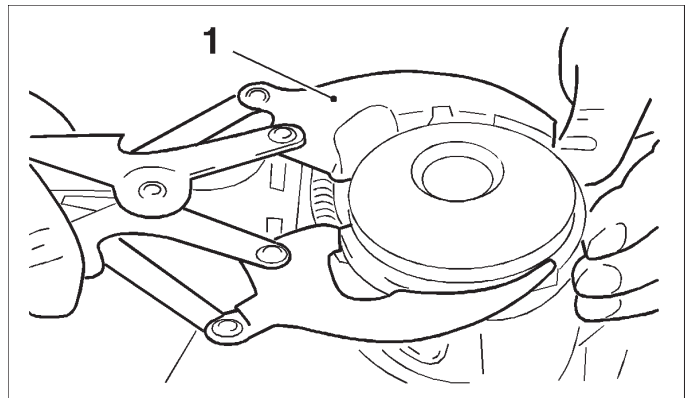

F 3822

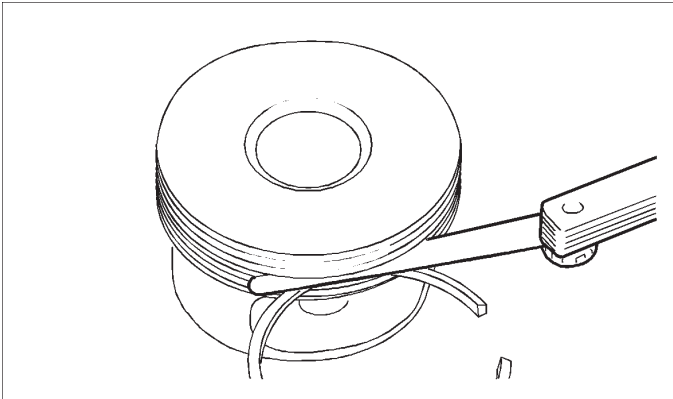
**Inspect**

Check piston ring vertical play with feeler gauge in piston ring groove.

Permissible vertical play:

Squared ring (1): 0.02-0.04 mm (0.0008-0.0015 in)

Tapered ring (2): 0.04-0.06 mm (0.0015-0.002 in)

Oil scraper ring (3): 0.01-0.03 mm (0.0004-0.001 in)

Install, Connect

Insert piston rings with piston ring pliers and identification "TOP" upwards in piston.

Piston ring positioning – piston rings (I) (rectangular and tapered compression ring) offset 120°. Oil scraper rings (II) – offset 25 to 50 mm to left and from right of gap in intermediate ring.

Install piston with con-rod – see operation "Piston with Con-rod, Remove and Install".

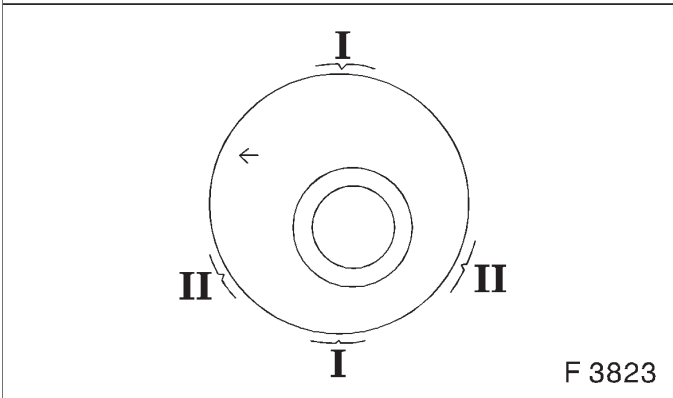
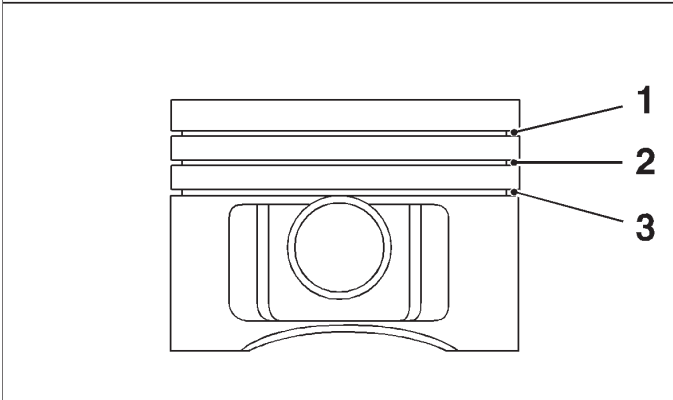

F 3823

Con-rod Bearing, Replace

Remove, Disconnect

Remove oil pan – see operation "Oil Pan, Remove and Install".

Remove oil intake tube (1) from oil pump and cylinder block.

Important

Mark order of con-rod bearing caps.

Remove con-rod bearing cap from con-rod.

The mating surfaces of the con-rods and the con-rod bearing caps form an individual fit and as a result must not be damaged or replaced under any circumstances. Do not lay con-rods and con-rod bearing caps on mating surfaces in order to avoid damage.

Press con-rod bearing out of con-rod and con-rod bearing cap.

Clean

Con-rod bearing journals and con-rod bearing caps.

Insert, Connect

Insert new con-rod bearing shells with engine oil.

Note sequence of con-rod bearing caps. Con-rod bearing caps – bead (1) of con-rod bearing caps points to transmission side.

Attach con-rod bearing cap to con-rod with new bolts – tightening torque 25 Nm / 18.5 lbf. ft. + 30°.

Attach oil intake manifold to oil pump with new seal ring – tightening torque 8 Nm / 6 lbf. ft.1).

Attach oil intake manifold to cylinder block – tightening torque 8 Nm / 6 lbf. ft.

Apply a bead of adhesive sealing compound (black) to joints of oil pump and rear crankshaft bearing cap.

Install oil pan – see operation "Oil Pan, Remove and Install".

1) Recut thread before reuse and insert bolts with screw locking compound (red). The installation time including the torque check is max. 10 min.

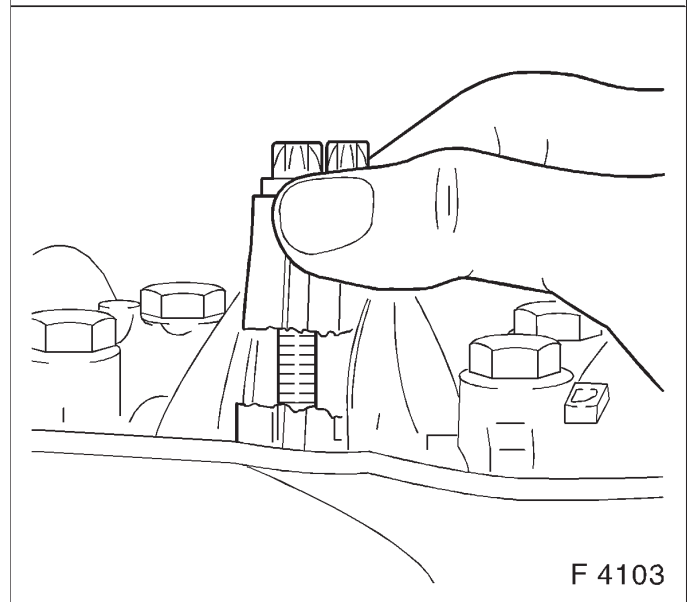
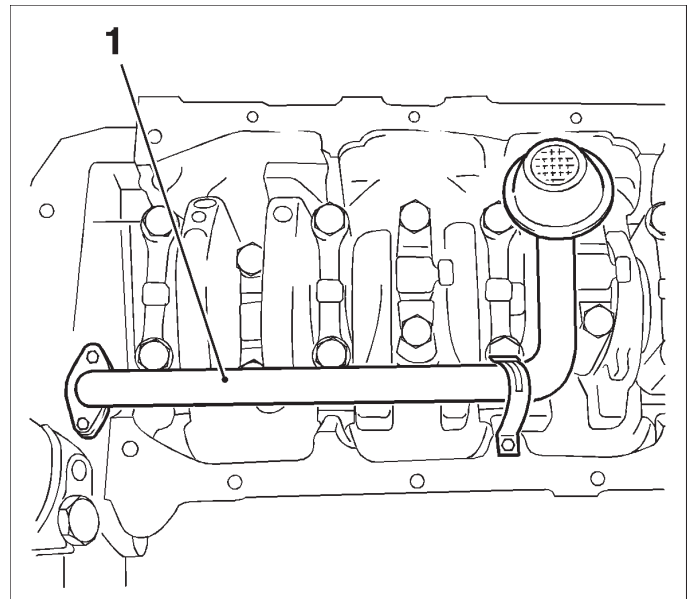

F 4103

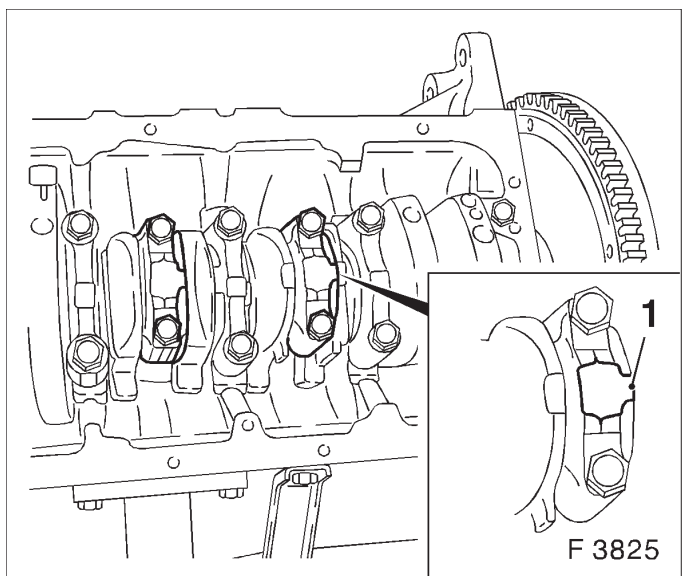

F 3825

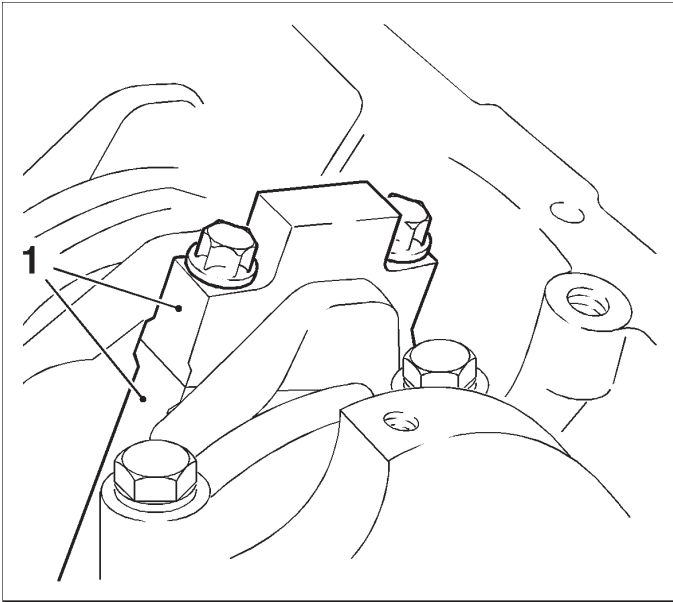

Con-rod Bearing Clearance, Check (Determine Bearing Clearance with Plastigage)

Remove, Disconnect

Mark installation position (1) of con-rod bearing cap – remove con-rod bearing cap from con-rod.

Important!

To prevent the strip from tearing when removing the con-rod bearing cap, remove grease from the con-rod journal and lightly oil con-rod bearing shell. Do not turn the crankshaft.

Measure

Route Plastigage (malleable plastic strip) over the entire width of the con-rod bearing journal.

Torque-Angle Method

Con-rod bearing cap to con-rod – tightening torque 25 Nm / 18 lbf. ft. + 30°.

The bolts can be reused for checking the con-rod bearing clearance.

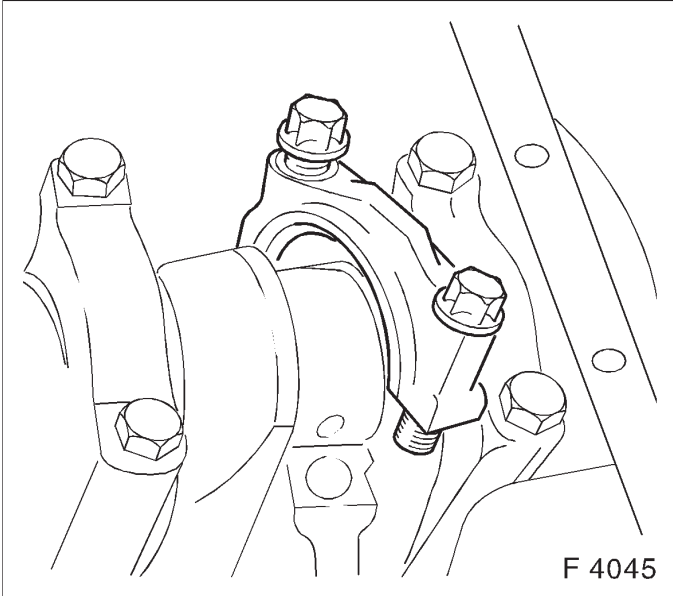

F 4045

Measure

Remove con-rod bearing cap again. Compare width of flattened plastic thread (arrow) with measuring scale. Permissible con-rod bearing clearance: 0.019-0.071 mm (0.0007-0.003 in)

Note:

When reading the value, do not confuse millimeters and inches on the measuring scale.

Install, Connect

Clean con-rod bearing journal and con-rod bearing shell and lubricate lightly.

Con-rod bearing cap to con-rod – note installation position of the con-rod bearing cap.

Attach con-rod bearing cap to con-rod with new bolts – tightening torque 25 Nm / 18.5 lbf. ft. + 30°.

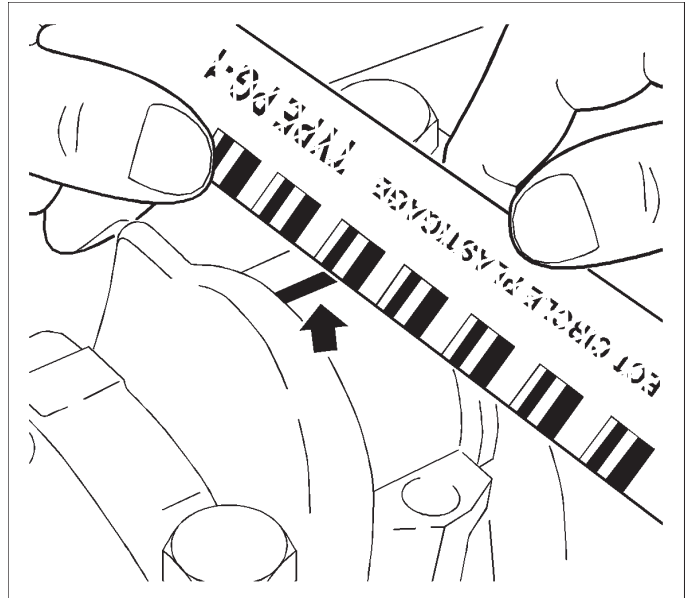

Con-rod Bearing Clearance, Check (Determine Bearing Clearance with Micrometer and Inside Micrometer)

Note:

Con-rod and crankshaft are removed.

Install, Connect

Con-rod bearing cap with con-rod bearing shell to con-rod – tightening torque 25 Nm / 18 lbf. ft. + 30°.

The bolts can be reused for checking the con-rod bearing clearance.

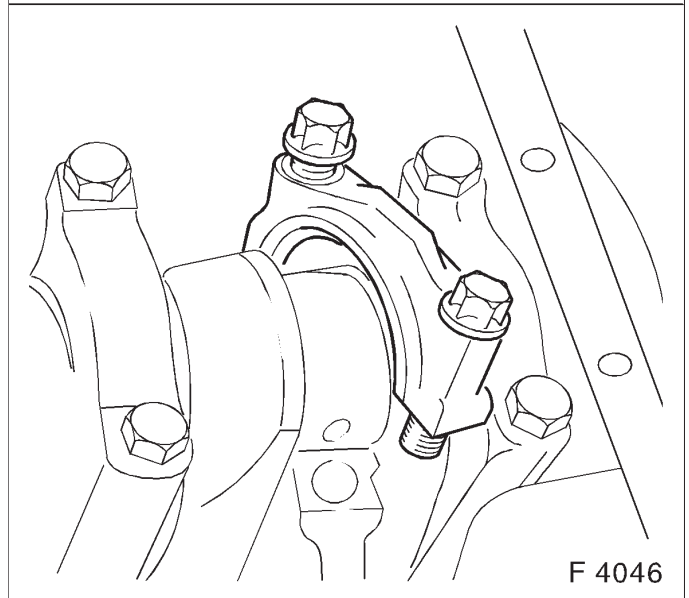

Install, Connect

Formula for calculating the average con-rod bearing diameter:

$$\frac{I + II + III}{3}$$

Example:

I	42.738 mm
II	42.732 mm
III	+ 42.741 mm
	<hr style="width: 100px; margin-left: 0;"/>
	128.211 mm / 3 = 42.737 mm

The average con-rod bearing diameter is 42.737 mm.

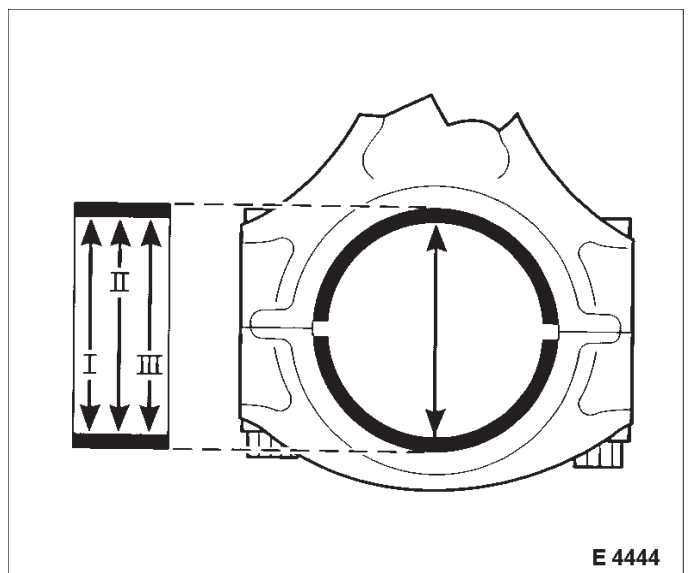

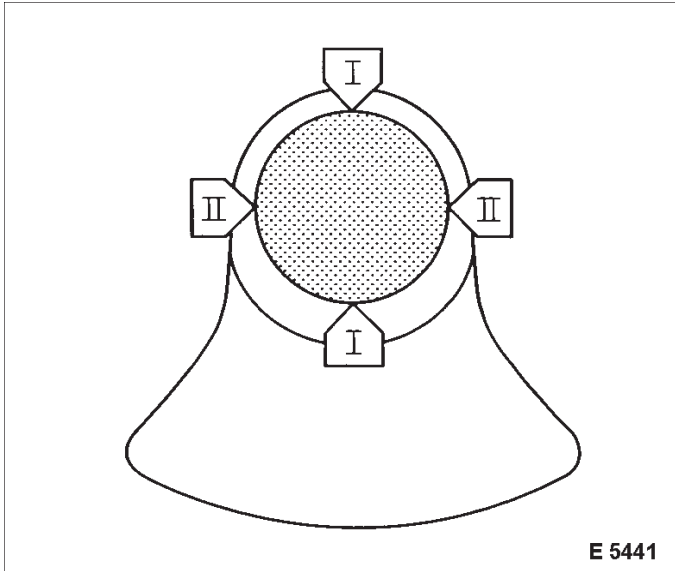
**Measure**

The con-rod bearing journal diameter is measured with a micrometer at points I and II and then calculated.

Formula for calculating the average con-rod bearing journal diameter: $I + II$

$$\frac{2}{2}$$

Example:

I 42.729 mm

II + 42.725 mm

$$\frac{85.454 \text{ mm}}{2} = 42.727 \text{ mm}$$

The average con-rod bearing journal diameter is 42.727 mm.

The con-rod bearing clearance is calculated from the difference in diameter between the con-rod bearing bore and the con-rod bearing journal.

Example:

Avg. con-rod bearing dia. 42.737 mm

Avg. con-rod bearing journal dia. - 42.727 mm

$$\underline{0.010 \text{ mm}}$$

Permissible con-rod bearing clearance: 0.019-0.071 mm (0.0007-0.003 in)

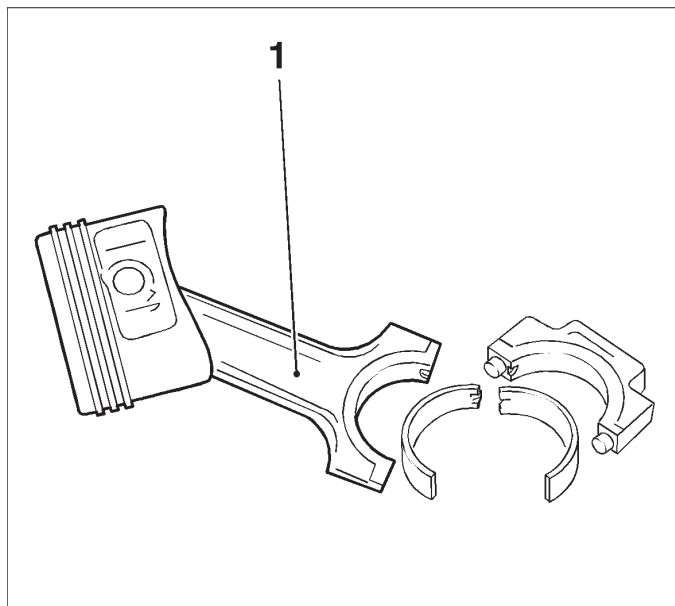
**Piston, Replace****Note:**

Pushing out of the piston pin is not permitted. If the piston, the piston pin or the con-rod defective, all above-mentioned parts must be replaced.

Remove, Disconnect

Remove piston with con-rod (1) – see operation "Piston with Con-rod, Remove and Install".

Install, Connect

Coat con-rod eye and upper part of the con-rod shaft with thermocolor pencil. The green coloring turns black when the required assembly temperature is reached. The colored mark (arrow) is not permitted to discolor over the entire length, but only up to the start of the con-rod shaft. Heat new con-rod at upper con-rod eye with heater plate. Assembly temperature: 280 °C / 536 °F to max. 320 °C / 608 °F.

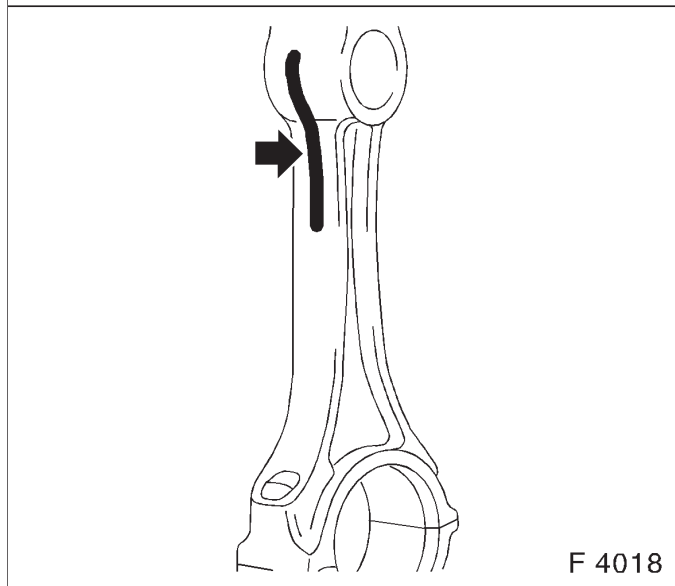

Important!

Installation position: Bead (arrow) on con-rod points to flattened area (arrow) of the piston pin eye.

Note:

Firmly seated piston pin cannot be pressed further. Perform assembly quickly.

Assemble

Con-rod (1), piston pin, piston (2).

Slide new piston pin to stop in piston with guide drift.

Install, Connect

Install piston with con-rod – see operation "Piston with Con-rod, Remove and Install".

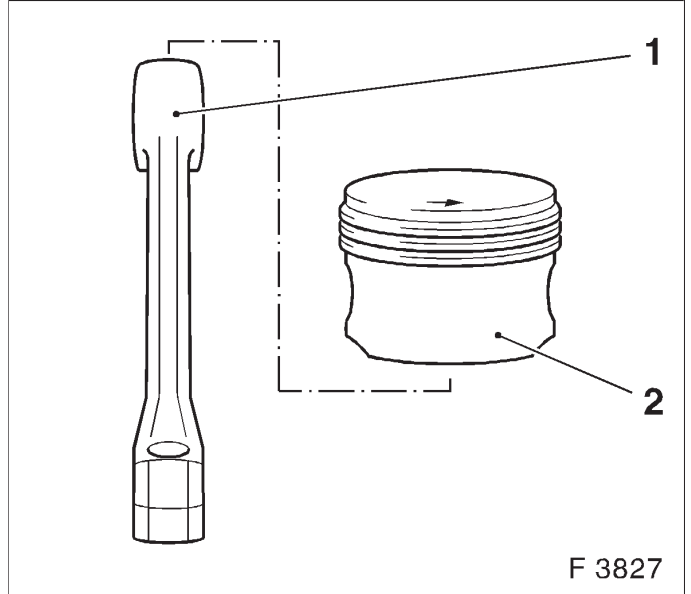
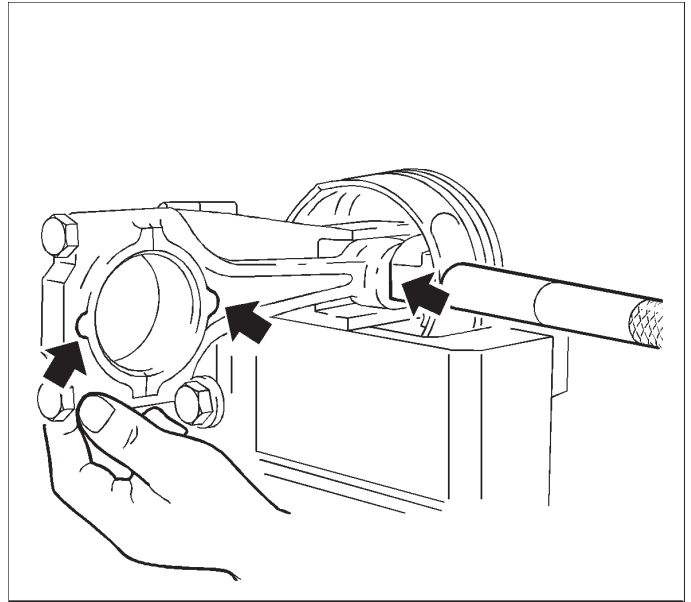

F 3827

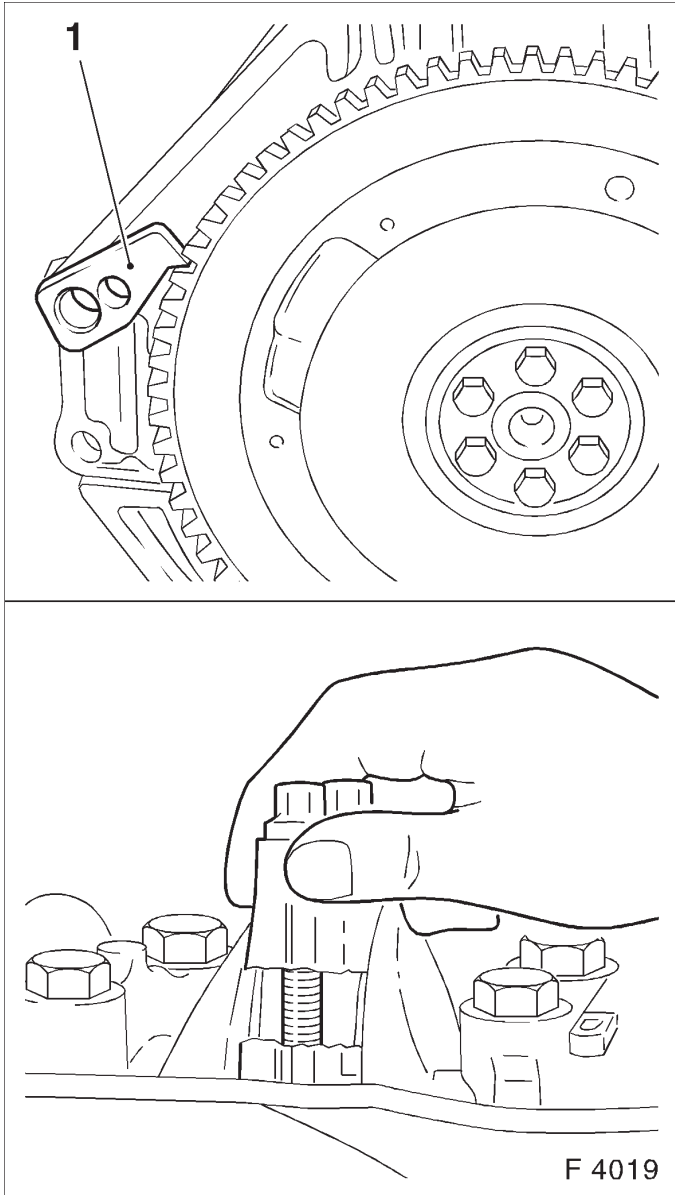

Crankshaft, Remove and Install

Remove, Disconnect

Remove engine – see operation "Engine, Remove and Install".

Mount engine with Adapter KM-412-10-A on Assembly Stands KM-412.

Remove oil pump – see operation "Oil Pump, Remove and Install".

Lock flywheel or drive disc with KM-652 (1) and remove from crankshaft.

Important!

Mark order of con-rod bearing caps. Remove con-rod bearing cap from conrod.

The mating surfaces of the con-rods and the con-rod bearing caps form an individual fit and as a result must not be damaged or replaced under any circumstances. Do not lay con-rods and con-rod bearing caps on mating surfaces in order to avoid damage.

F 4019

Remove, Disconnect

Identify sequence of crankshaft bearing caps. Remove crankshaft bearing cap from cylinder block.
Remove crankshaft from cylinder block.

Clean

Clean all parts.

Inspect

Check crankshaft – see operation "Crankshaft, Check".

Install, Connect

Coat new bearing shells with engine oil and insert in cylinder block and bearing cap. Insert crankshaft carefully in cylinder block. Seat of crankshaft can be corrected by lightly tapping on crankshaft webs (1) with rubber hammer.

Install, Connect

Apply a bead of adhesive sealing compound (black) to grooves of rear crankshaft bearing cap. Install crankshaft and con-rod bearing cap.
Note marks and installation position.

Torque – Angle Method

Crankshaft bearing cap to cylinder block – 50 Nm / 37 lbf. ft + 45° + 15°1)2).

Con-rod bearing cap to con-rod – 25 Nm / 18.5lbf. ft. + 30°1)

Install, Connect

Install crankshaft rear seal ring – see operation "Seal Ring, Crankshaft, Rear Replace".

Lock flywheel with KM-652. Flywheel with new bolts to crankshaft – tightening torque 35 Nm / 26 lbf. ft. + 30° + 15°. Install oil pump – see operation "Oil Pump, Remove and Install". Remove engine from Overhaul Stand KM-412 and remove Adapter KM-412-10 from engine. Install engine – see operation "Engine, Remove and Install".

1) Use new bolts.

2) After assembly of bearing cap, press in adhesive sealing compound (black) from above again until adhesive sealing compound (black) escapes from the joints.

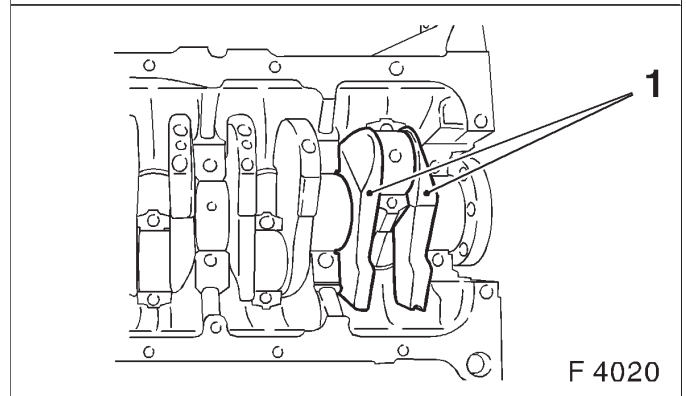
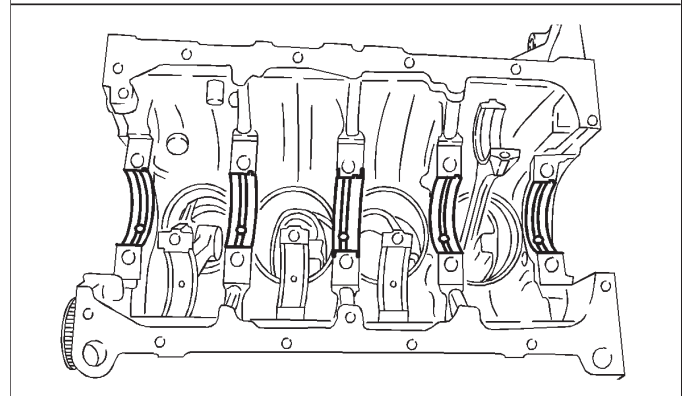
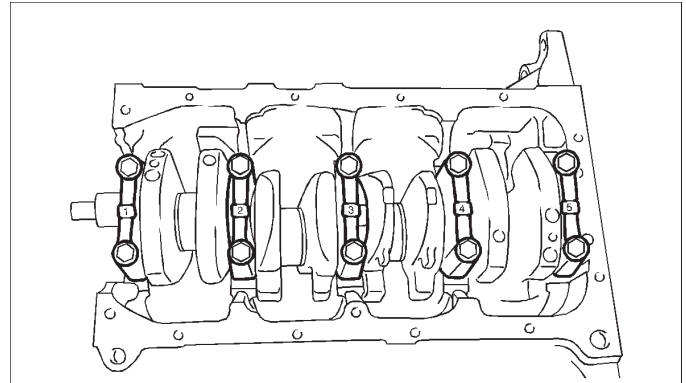

F 4020

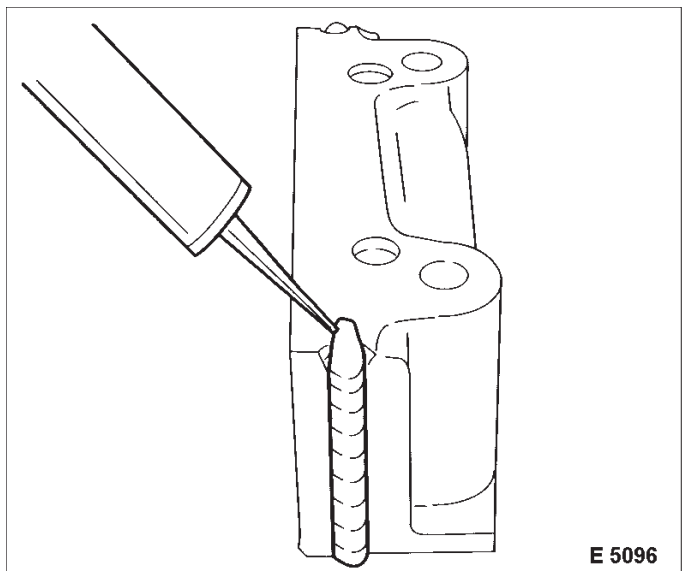

E 5096

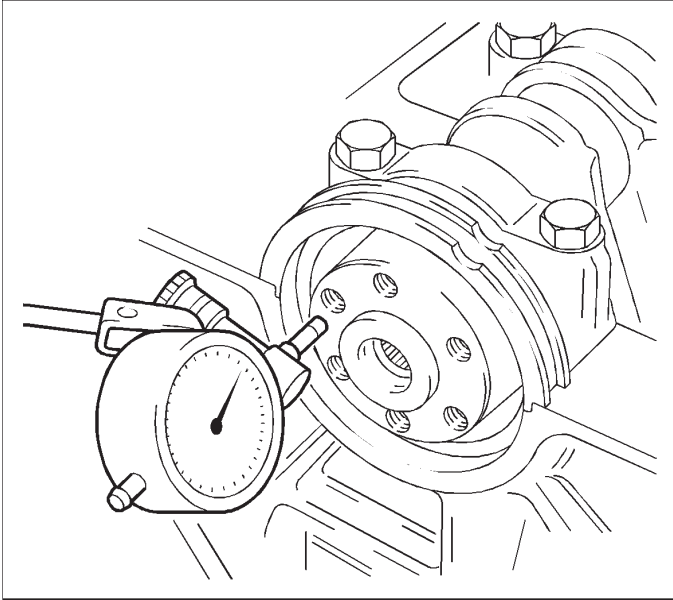

Crankshaft, Check
Crankshaft End Clearance, Check

Measure

Attach Dial Gauge MKM-571-B with dial gauge bracket to one face of cylinder block and position probe of dial gauge on crankshaft. Slide crankshaft in longitudinal direction. Permissible crankshaft longitudinal play: 0.100-0.202 mm (0.004-0.008 in)

Crankshaft Out-of-round, Check

Inspect

Remove crankshaft bearing cap.

Attach Dial Gauge MKM-571-B with dial gauge bracket to cylinder block. Apply probe of the Dial Gauge MKM-571-B to crankshaft bearing journal. Turn crankshaft uniformly. Max. perm. out-of-round: 0.03 mm (0.001 in).

Crankshaft bearing cap with new bolts to cylinder block – 50 Nm / 37 lbf. ft. + 45° + 15°.

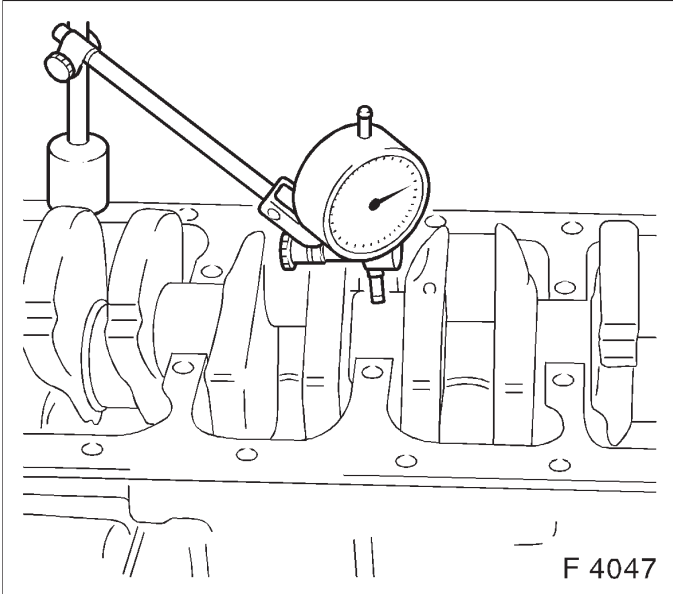

Crankshaft Bearing Play, Check (Determine Bearing Play with Plastigage)

Inspect

Bearing play – crankshaft bearing cap removed.

Important!

To prevent thread from tearing when removing con-rod bearing cap, remove grease from con-rod journal and lightly oil con-rod bearing shell. Do not turn crankshaft.

Measure

With "Plastigage" (deformable plastic thread).

Cut thread to bearing width and lay axially between crankshaft journal and bearing shell (arrow). Install crankshaft bearing cap with torque – tightening torque 50 Nm / 37 lbf. ft. + 45° + 15°.

Note:

The bolts can be reused for checking crankshaft bearing clearance.

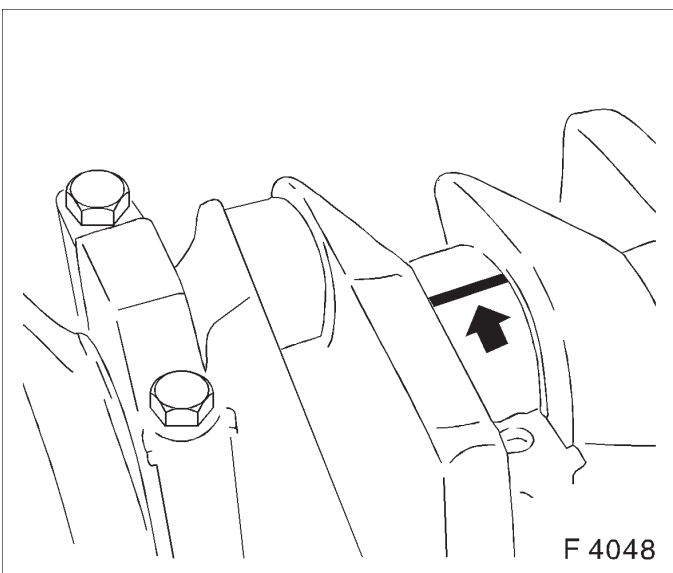

Remove, Disconnect
Remove crankshaft bearing cap.

Measure
Compare width of flattened plastic thread (arrow) with measuring scale.
”Plastigage” is available for various measuring ranges.
Perm. crankshaft bearing play: 0.015-0.041 mm (0.0005-0.0015 in).

Torque – Angle Method
Attach crankshaft bearing cap to cylinder block with new bolts – 50 Nm / 37 lbf. ft. + 45° + 15°.

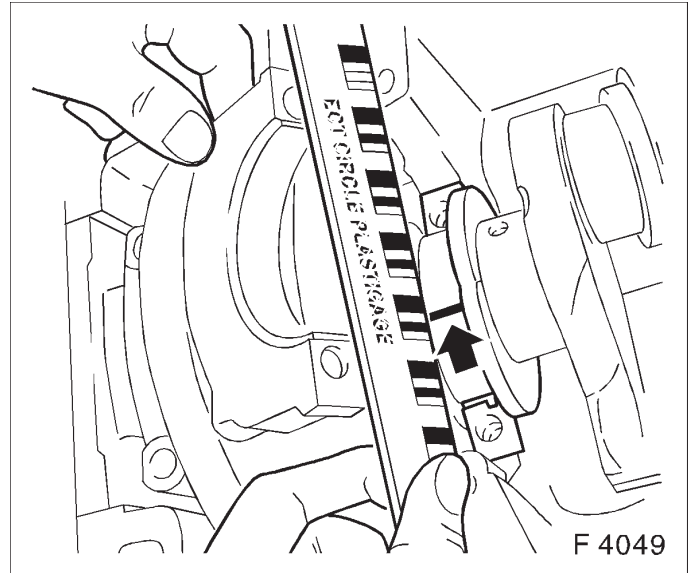

Crankshaft Bearing Clearance, Check (Determine Crankshaft Bearing Clearance Using External Micrometer and Inside Micrometer)

The crankshaft is removed.

Install, Connect
Install crankshaft bearing cap with crankshaft bearing shell at cylinder block – tightening torque 50 Nm / 37 lbf. ft. + 45° + 15°. To check the crankshaft bearing play, bolt can be reused.

Measure
The average crankshaft bearing diameter is determined using an inside micrometer at points I, II and III and then calculated.

Formula for calculating the average crankshaft bearing diameter:

$$\frac{I + II + III}{3}$$

Example:

I	54.972 mm
II	54.981 mm
III	+ 54.984 mm
<hr/>	
	164.937 mm / 3 = 54.979 mm

The average crankshaft bearing diameter is 54.979 mm.

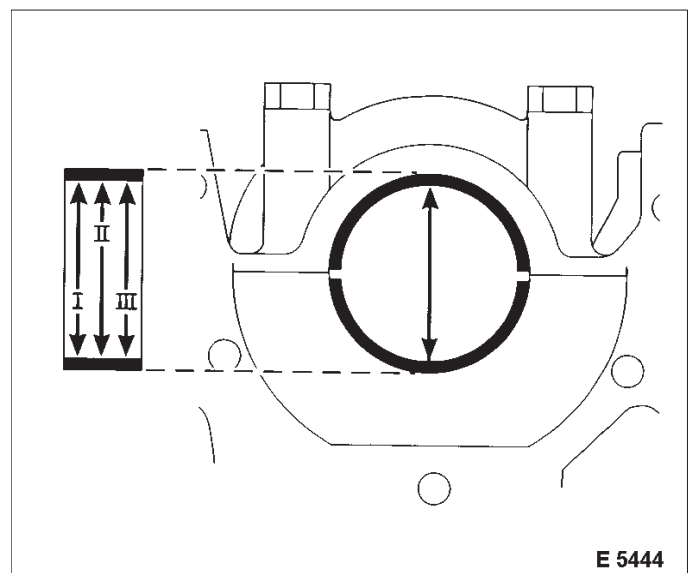

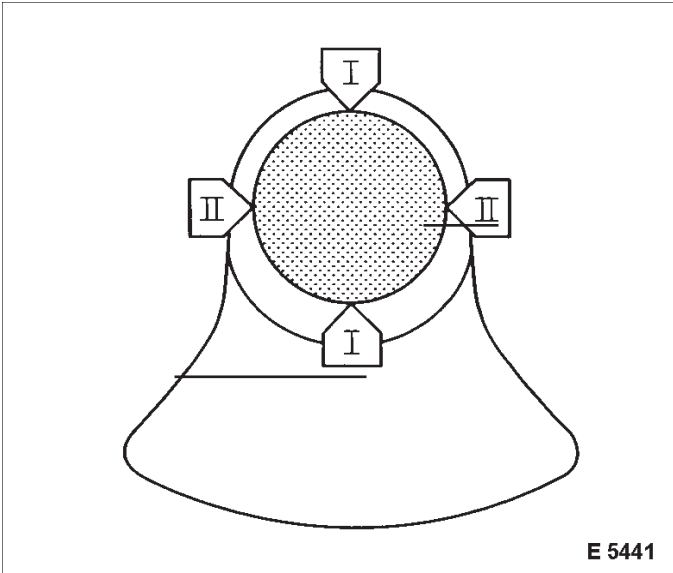

Measure

The crankshaft journal diameter is measured with a micrometer at points I and II and then calculated.

Formula for calculating the average crankshaft bearing journal diameter:
$$\frac{I + II}{2}$$

Example:

$$\begin{array}{r} I \quad \quad \quad 54.962 \text{ mm} \\ II \quad \quad + \quad 54.964 \text{ mm} \\ \hline 109.926 \text{ mm} / 2 = 54.963 \text{ mm} \end{array}$$

The average crankshaft journal diameter is 54.963 mm.

The crankshaft clearance is calculated from the difference in diameter between the crankshaft bearing bore and crankshaft journal.

Example:

$$\begin{array}{r} \text{Average crankshaft bearing dia.} \quad 54.979 \text{ mm} \\ \text{Average crankshaft journal dia.} \quad - \quad 54.963 \text{ mm} \\ \hline 0.016 \text{ mm} \end{array}$$

Permissible crankshaft bearing play: 0.015-0.041 mm (0.0005-0.0015 in)

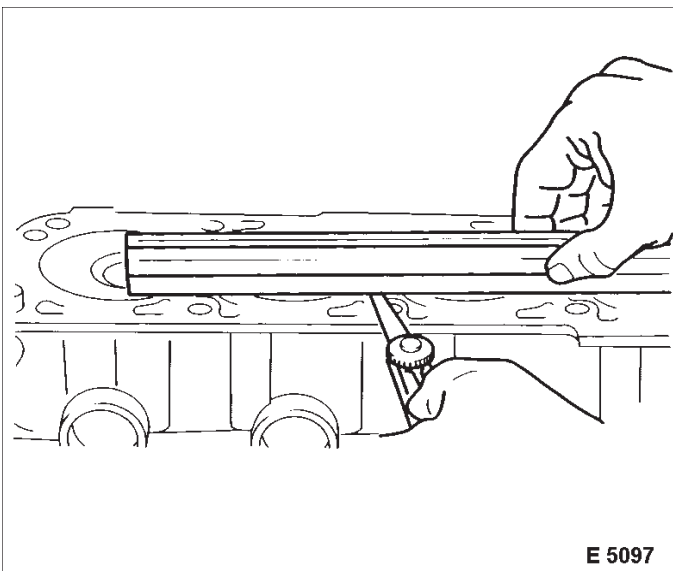

Cylinder Block, Check for Plane Surface

Clean

Clean sealing surface and remove sealant remnants.

Inspect

Check sealing surfaces in length and width for deformation and check for warping along the diagonals – use straight edge.

Oil Circuit**Oil Filter, Replace****Remove, Disconnect**

Remove oil filter with KM-726-A (1) – place collecting basin underneath.

Install, Connect

Coat seal ring of new oil filter lightly with engine oil and attach to cylinder block – tightening torque 15 Nm / 11 lbf. ft.

Inspect

Check engine oil level and correct if necessary.

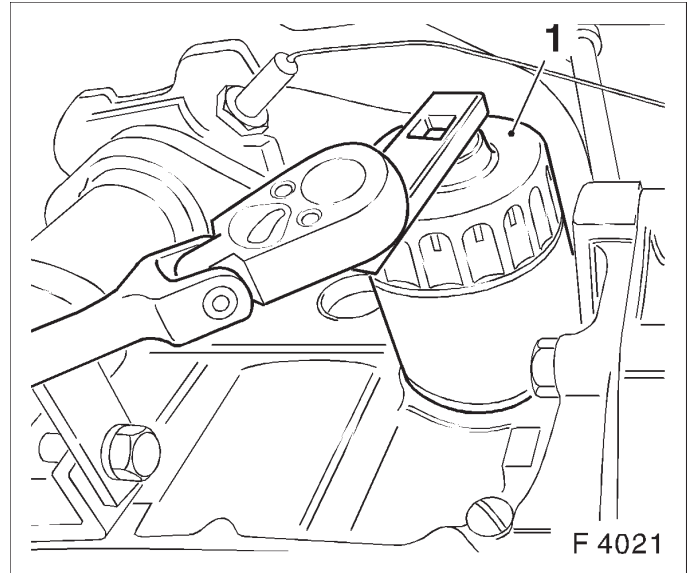
**Bypass Valve, Replace****Remove, Disconnect**

Remove oil filter – see operation "Oil Filter, Replace".

Using tap (1) (M10 – 3rd speed) cut thread in bypass valve, screw in M10 bolt and remove bypass valve from seat.

Install, Connect

Drive in bypass valve up to stop using drift (j approx. 15 mm).

Install oil filter – see operation "Oil Filter, Replace".

Inspect

Check engine oil level and correct if necessary.

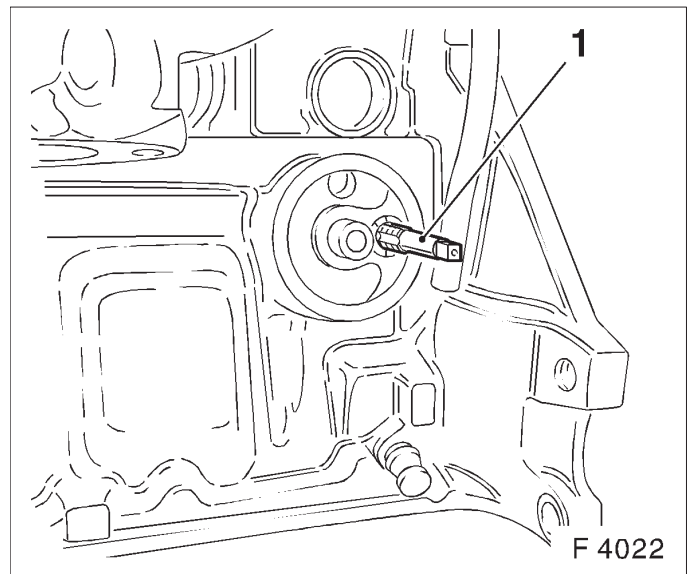
**Seal Ring – Oil Pump, Replace****Front Seal Ring – Crankshaft, Replace****Remove, Disconnect**

Remove air cleaner housing with air intake cover.

Remove upper part of toothed belt cover – see operation "Toothed Belt Cover – Upper Part, Remove and Install".

Remove ribbed V-belts – see operation "Ribbed V-belts, Remove and Install".

Remove ribbed V-belt tensioner – see operation "Ribbed V-belt Tensioner, Remove and Install".

Remove lower part of toothed belt cover – see operation "Toothed Belt Cover – Lower Part, Remove and Install".

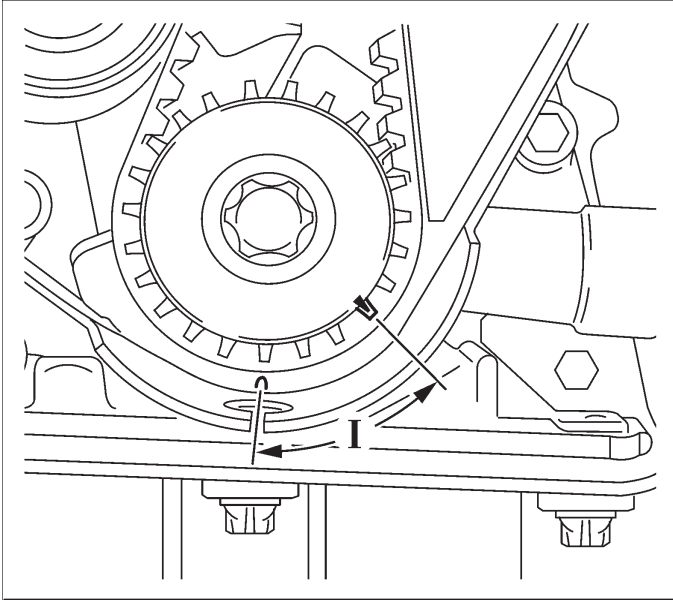

Important!

Before dismantling the toothed belt – screw fastening bolt for toothed belt drive gear into crankshaft and move crankshaft in engine rotational direction by 60° (dimension I) to before TDC mark.

Remove, Disconnect

Remove toothed belt – see operation "Toothed Belt, Remove and Install".

Remove fastening bolt from toothed belt drive gear and pull toothed belt drive gear from crankshaft.

Edge out crankshaft seal ring (1) with suitable tool.

Important!

Do not damage sealing surfaces.

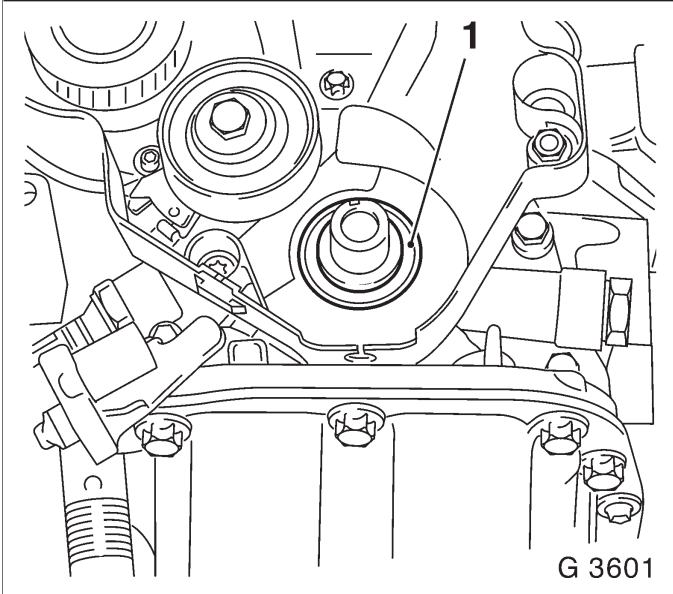

G 3601

Install, Connect

Slide Protective Sleeve KM-417 (1) onto crankshaft journal. Lightly coat sealing lip of the new seal ring with silicon grease (white) and slide over the protective sleeve onto crankshaft journal.

Remove, Disconnect

Remove protective sleeve of KM-417 from crank journal.

Install, Connect

Press seal ring with KM-417 (3) in oil pump – use bolt (2) and washer (4) of toothed belt drive gear. Slide toothed belt drive gear onto crankshaft. Install toothed belt – see operation "Toothed Belt, Remove and Install".

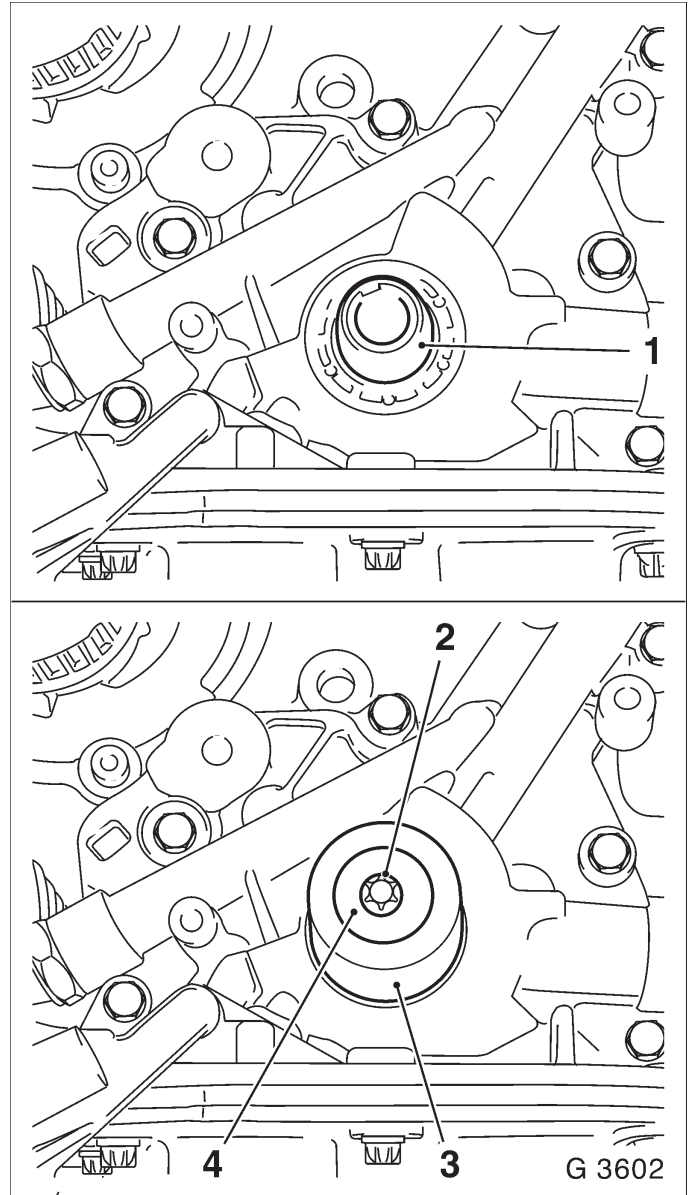
**Install, Connect**

Install lower part of toothed belt cover – see operation "Toothed Belt Cover – Lower Part, Remove and Install".

Install ribbed V-belt tensioner – see operation "Ribbed V-belt Tensioner, Remove and Install".

Install ribbed V-belt – see operation "Ribbed V-belt, Remove and Install".

Install upper part of toothed belt cover – see operation "Toothed Belt Cover – Upper Part, Remove and Install".

Install air cleaner housing with air intake cover.

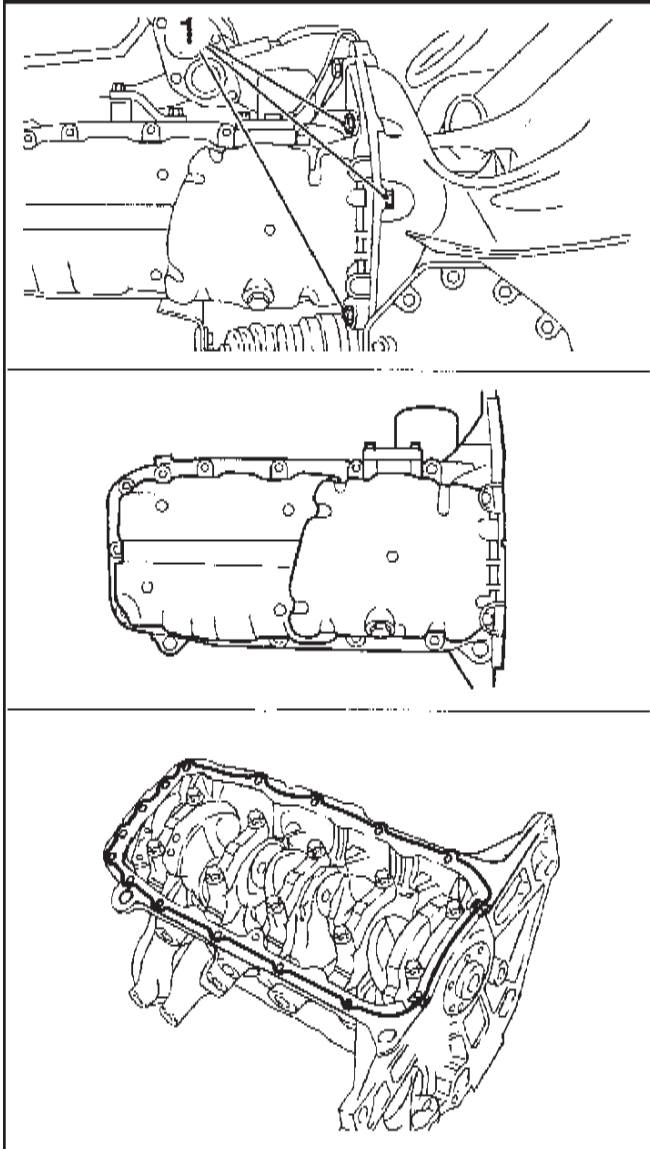

Oil Pan, Remove and Install

Remove

Open oil drain bolt – place collecting basin underneath.

Remove fastening bolts (1) from transmission housing.

Remove oil pan from cylinder block and oil pump.

Clean

Clean sealing surfaces and remove gasket remnants.

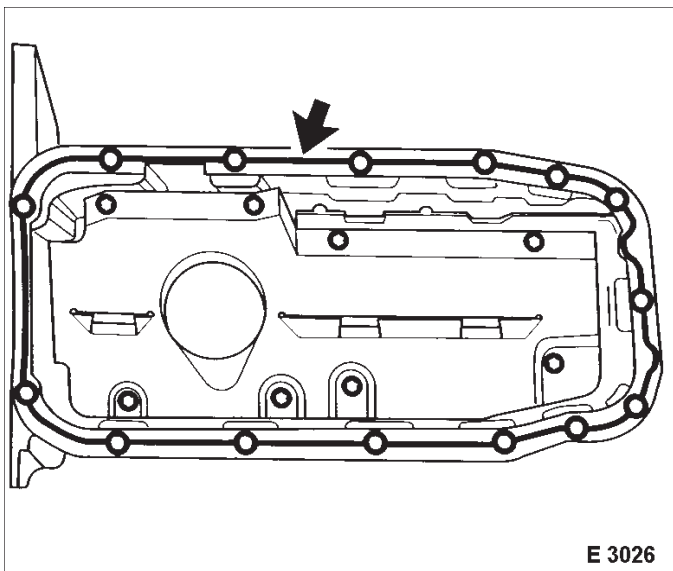

Install, Connect

Apply a bead of adhesive sealing compound around oil pan sealing flange. Install oil pan to oil pump, cylinder block. Attach oil drain bolt to oil pan with new seal ring – tightening torque 55 Nm / 40.6 lbf. ft.

Important!

Installation sequence:

1. Tighten all bolts loosely.
2. Tighten bolts on cylinder block and oil pump – tightening torque 10 Nm / 7.5 lbf. ft.1).
3. Tighten bolts on transmission housing – tightening torque 40 Nm / 29.5 lbf. ft.

1) Recut thread before reuse and insert bolts with screw locking compound (red). The installation time including the torque check is max. 10 min.

Install, Connect

For version with hex bolts – tightening torque 35 Nm / 26 lbf. ft.1).

For version with hex nuts – tightening torque 45 Nm / 33 lbf. ft.2).

Fill engine oil up to "MAX" at dipstick.

- 1) Insert bolts with mounting paste (white).
- 2) Use new nut(s).

Oil Pump, Remove and Install**Important!**

Prior to removing toothed belt – set crankshaft to approx. 60° (dimension I) before TDC mark.

Remove, Disconnect

Remove oil pan – see operation "Oil Pan, Remove and Install".

Remove air cleaner housing with air intake cover.

Remove upper part of toothed belt cover – see operation "Toothed Belt Cover – Upper Part, Remove and Install".

Remove ribbed V-belts – see operation "Ribbed V-belts, Remove and Install".

Remove ribbed V-belt tensioner – see operation "Ribbed V-belt Tensioner, Remove and Install".

Remove lower part of toothed belt cover – see operation "Toothed Belt Cover – Lower Part, Remove and Install".

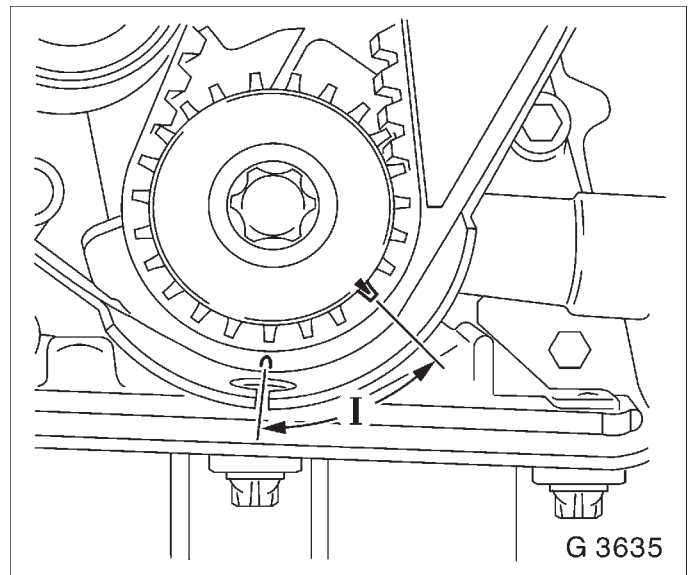

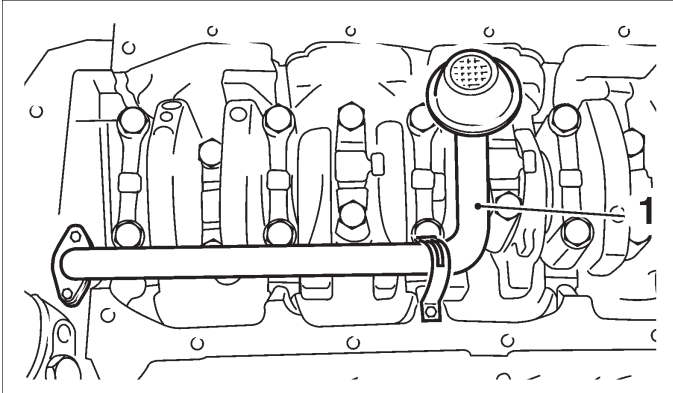

Remove, Disconnect

Remove toothed belt – see operation "Toothed Belt, Remove and Install".

Remove toothed belt tension roller – see operation "Toothed Belt Tension Roller, Remove and Install".

Rear toothed belt cover – see operation "Toothed Belt Cover – Rear, Remove and Install".

Remove oil intake tube (1) from oil pump and cylinder block.

Disconnect wiring harness plug (2) from oil pressure switch.

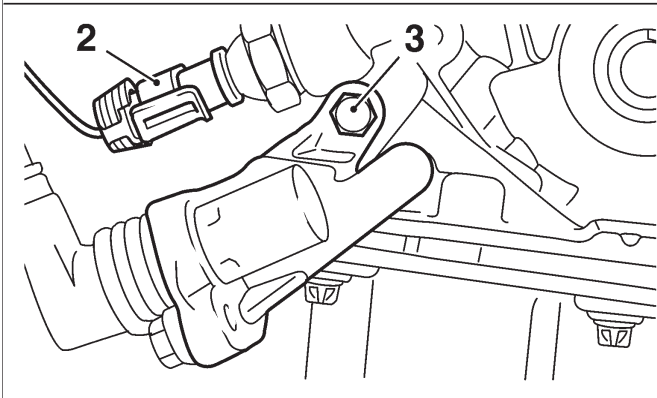

Remove crankshaft position sensor bolt (3).

Detach oil pump (4) from cylinder block.

Edge seal ring (5) out of oil pump.

Clean

Clean sealing surfaces and remove gasket remnants.

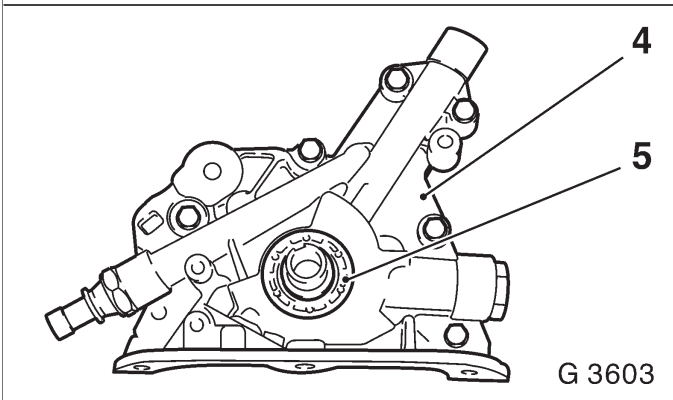

G 3603

Install, Connect

Attach oil pump with new seal (1) to cylinder block – tightening torque 10 Nm / 7 lbf. ft.

Slide Protective Sleeve KM-417 onto crankshaft journal.

Lightly coat sealing lip of the new seal ring with silicon grease (white) and slide over the protective sleeve onto crankshaft journal.

Remove, Disconnect

Remove protective sleeve from crankshaft journal.

Install, Connect

Press seal ring with KM-417 (3) in oil pump – use bolt (2) and washer (4) of toothed belt drive gear.

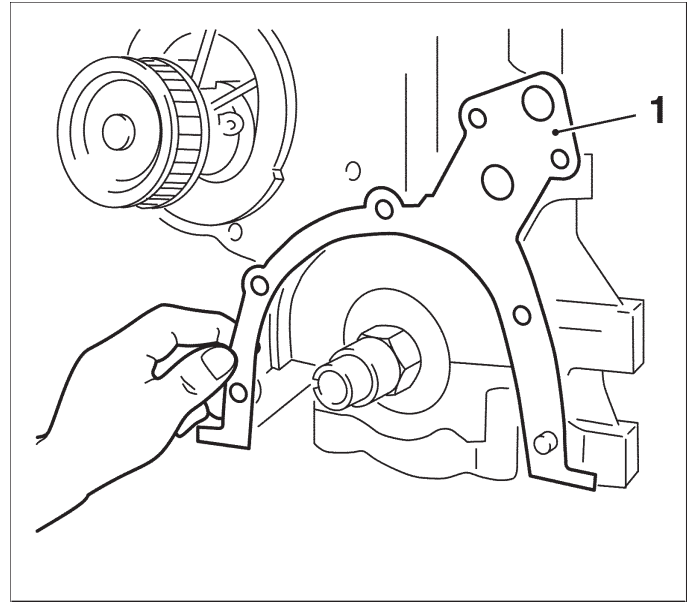
**Install, Connect**

Connect wiring harness plug to oil pressure switch.

Attach crankshaft position sensor oil intake manifold to oil pump with new seal ring – tightening torque 8 Nm / 6 lbf. ft.1).

Attach oil intake manifold to cylinder block – tightening torque 8 Nm / 6 lbf. ft.

Install rear toothed belt cover – see operation "Toothed Belt Cover – Rear, Remove and Install".

Install toothed belt tension roller – see operation "Toothed Belt Tension Roller, Remove and Install".

Install toothed belt – see operation "Toothed Belt, Remove and Install".

Install lower part of toothed belt cover – see operation "Toothed Belt Cover – Lower Part, Remove and Install".

Install ribbed V-belt tensioner – see operation "Ribbed V-belt Tensioner, Remove and Install".

Install ribbed V-belt – see operation "Ribbed V-belt, Remove and Install".

Install upper part of toothed belt cover – see operation "Toothed Belt Cover – Upper Part, Remove and Install".

Install air cleaner housing with air intake cover.

Install oil pan – see operation "Oil Pan, Remove and Install".

1) Recut thread before reuse and insert bolts with screw locking compound (red). The installation time including the torque check is max. 10 min.

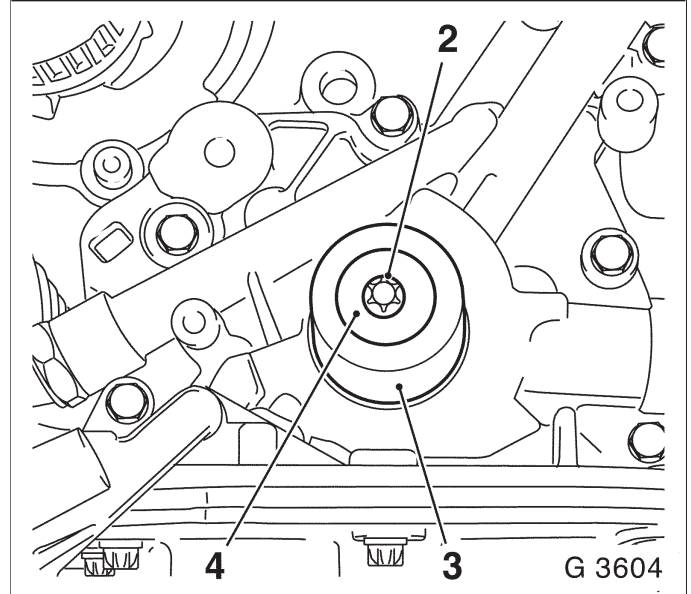

Oil Pump, Check

Remove, Disconnect

Remove oil pan – see operation "Oil Pan, Remove and Install".

Remove air cleaner housing with air intake cover.

Remove upper part of toothed belt cover – see operation "Toothed Belt Cover – Upper Part, Remove and Install".

Remove ribbed V-belts – see operation "Ribbed V-belts, Remove and Install".

Remove ribbed V-belt tensioner – see operation "Ribbed V-belt Tensioner, Remove and Install".

Remove lower part of toothed belt cover – see operation "Toothed Belt Cover – Lower Part, Remove and Install".

Remove toothed belt – see operation "Toothed Belt, Remove and Install".

Remove toothed belt tension roller – see operation "Toothed Belt Tension Roller, Remove and Install".

Rear toothed belt cover – see operation "Toothed Belt Cover – Rear, Remove and Install".

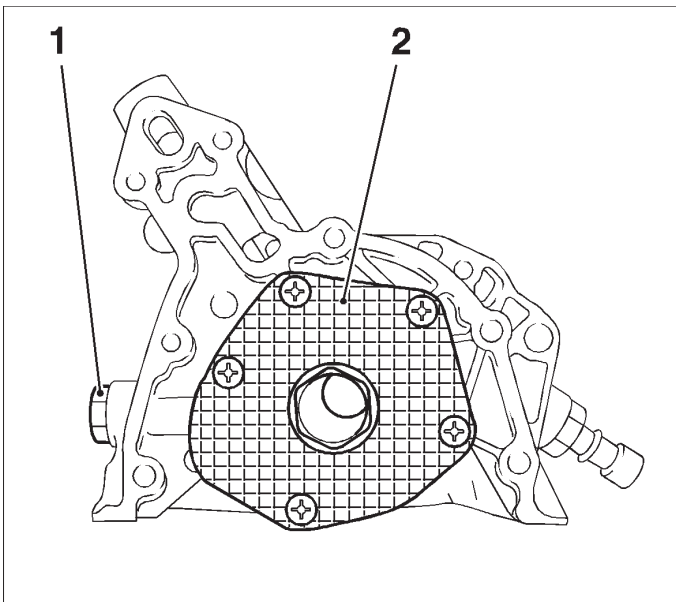

Remove, Disconnect

Remove oil pump – see operation "Oil Pump, Remove and Install".

Remove safety valve (1) and oil pump cover (2) from oil pump.

Inspect

Check gap of gear pair with feeler gauge (4) and straight edge (3). Dimension – 0.08-0.15 mm (0.003-0.005 in). Check oil pump, oil pump cover and safety valve for signs of wear.

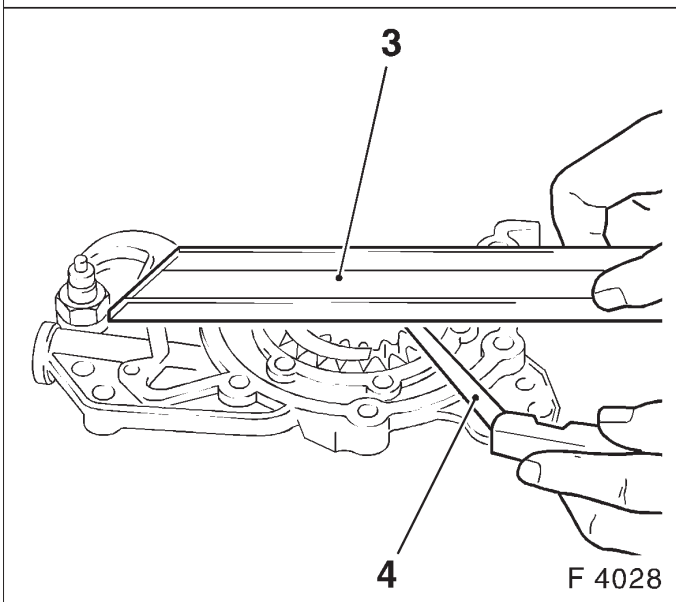

Install, Connect

Oil pump cover to oil pump Attach – tightening torque 6 Nm / 4 lbf. ft. safety valve with new seal ring in oil pump Install – tightening torque 50 Nm / 37 lbf. ft.

Install oil pump – see operation "Oil Pump, Remove and Install".

Install, Connect

Install rear toothed belt cover – see operation "Toothed Belt Cover – Rear, Remove and Install".

Install toothed belt tension roller – see operation "Toothed Belt Tension Roller, Remove and Install".

Install toothed belt – see operation "Toothed Belt, Remove and Install".

Install lower part of toothed belt cover – see operation "Toothed Belt Cover – Lower Part, Remove and Install".

Install ribbed V-belt tensioner – see operation "Ribbed V-belt Tensioner, Remove and Install".

Install ribbed V-belt – see operation "Ribbed V-belt, Remove and Install".

Install upper part of toothed belt cover – see operation "Toothed Belt Cover – Upper Part, Remove and Install".

Install air cleaner housing with air intake cover.

Install oil pan – see operation "Oil Pan, Remove and Install".

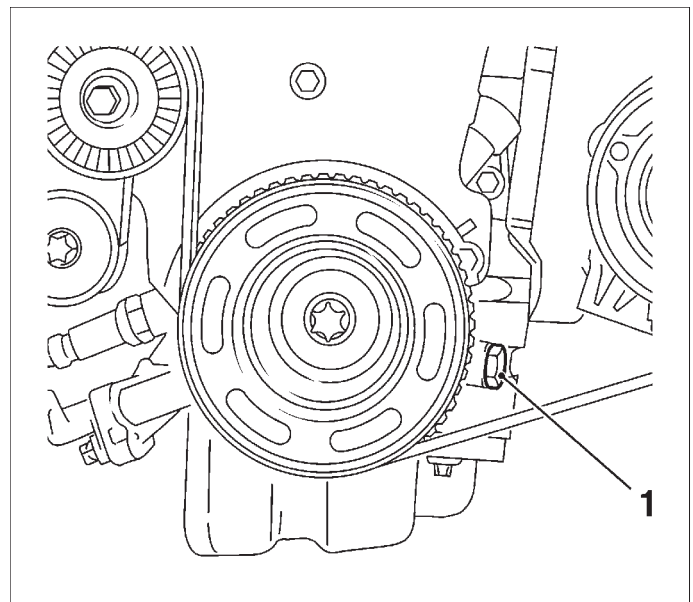

Safety Valve, Remove and Install

Remove, Disconnect

Remove closure plug (1) from oil pump – remove seal ring, spring, piston from oil pump.

Install, Connect

Insert piston (2) – ensure installation position is correct. Insert spring (3) in oil pump. Attach closure plug (5) to oil pump with new seal ring (4) – tightening torque 50 Nm / 37 lbf. ft.

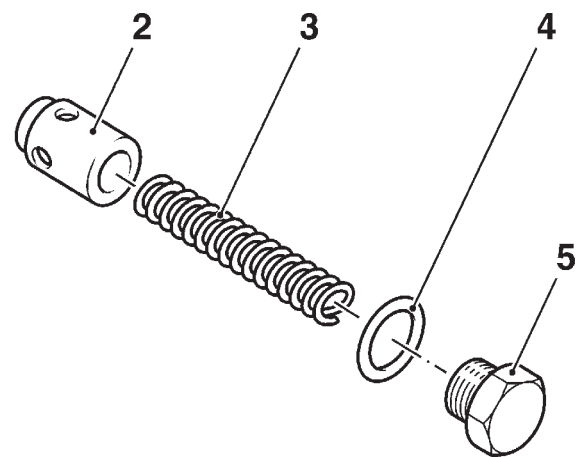

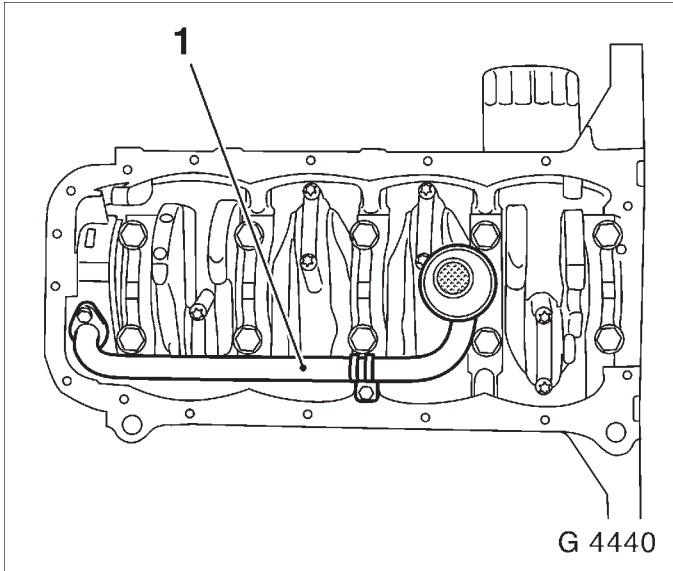

Oil Intake Pipe, Remove and Install

Remove, Disconnect

Remove oil pan – see operation "Oil Pan, Remove and Install".

Remove oil intake tube (1) from oil pump and cylinder block.

Install, Connect

Attach oil intake manifold to oil pump with new seal ring – tightening torque 8 Nm / 6 lbf. ft.1).

Attach oil intake manifold to cylinder block – tightening torque 8 Nm / 6 lbf. ft.

Install oil pan – see operation "Oil Pan, Remove and Install".

1) Recut thread before reuse and insert bolts with screw locking compound (red). The installation time including the torque check is max. 10 min.

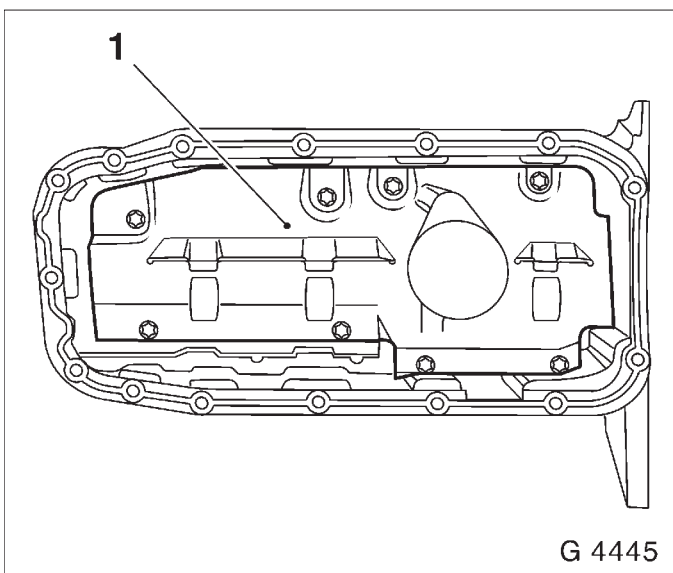

Oil Baffle Plate, Remove and Install

Remove, Disconnect

Remove oil pan – see operation "Oil Pan, Remove and Install".

Remove oil baffle plate (1).

Install, Connect

Attach oil baffle plate to oil pan – tightening torque 8 Nm / 6 lbf. ft.

Install oil pan – see operation "Oil Pan, Remove and Install".

Oil Pressure Switch, Remove and Install

Remove, Disconnect

Detach wiring harness plug (1) from oil pressure switch.

Disconnect oil pressure switch (2) from oil pump – place collection pan underneath.

Install, Connect

Attach oil pressure switch to oil pump with new seal ring – tightening torque 30 Nm / 22 lbf. ft.

Connect wiring harness plug to oil pressure switch.

Inspect

Check engine oil level and correct if necessary.

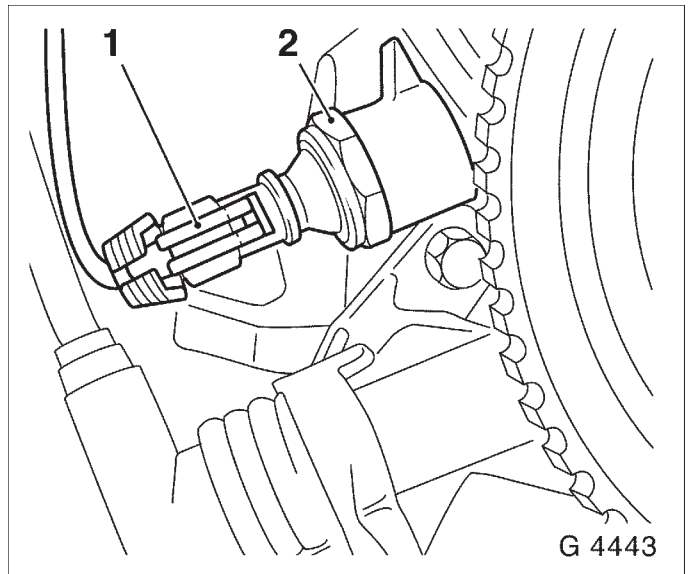

Oil Dipstick Guide Tube, Remove and Install

Remove, Disconnect

Withdraw oil dipstick guide tube (1) from cylinder block.

Install, Connect

Push new seal ring (2) onto oil dipstick guide tube and lightly coat with engine oil.

Insert oil dipstick guide tube up to stop in cylinder block.

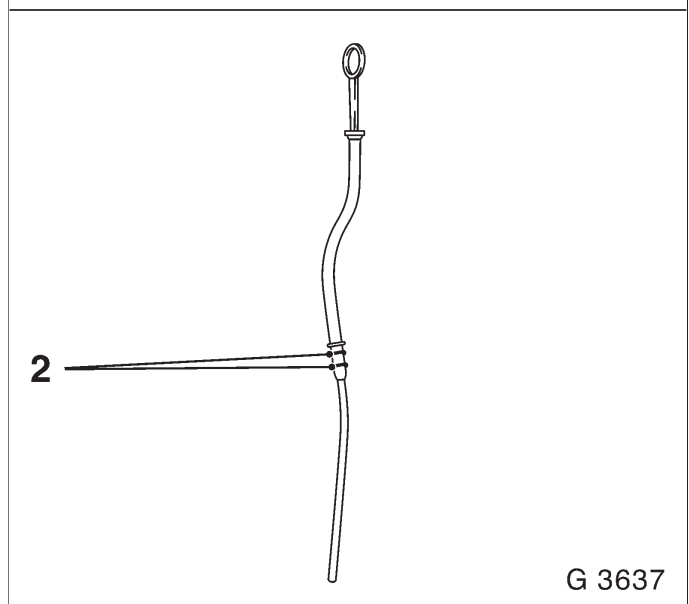
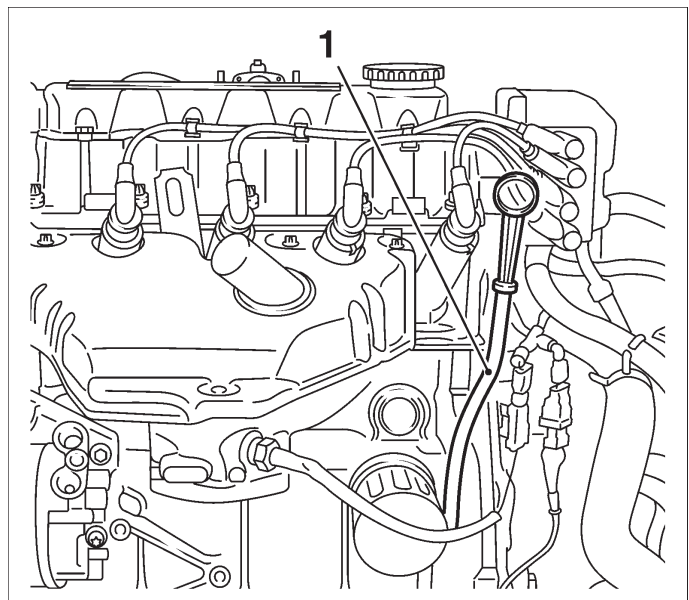

Thermostat, Remove and Install

Remove, Disconnect

Open coolant drain bolt – collect escaping coolant.

Remove coolant hose from thermostat housing.

Remove air cleaner housing with air intake cover.

Remove upper part of toothed belt cover – see operation "Toothed Belt Cover – Upper Part, Remove and Install".

Remove ribbed V-belts – see operation "Ribbed V-belts, Remove and Install".

Remove ribbed V-belt tensioner – see operation "Ribbed V-belt Tensioner, Remove and Install".

Remove lower part of toothed belt cover – see operation "Toothed Belt Cover – Lower Part, Remove and Install".

Remove toothed belt – see operation "Toothed Belt, Remove and Install".

Remove toothed belt tension roller – see operation "Toothed Belt Tension Roller, Remove and Install".

Remove, Disconnect

Rear toothed belt cover – see operation "Toothed Belt Cover – Rear, Remove and Install".

Remove thermostat housing (1) from cylinder head.
Remove thermostat (2) from cylinder head.

Clean

Clean sealing surfaces and remove gasket remnants.

Install, Connect

Install thermostat (2) into cylinder head with new seal ring.

Attach thermostat housing to cylinder head – 10 Nm / 7 lbf. ft.

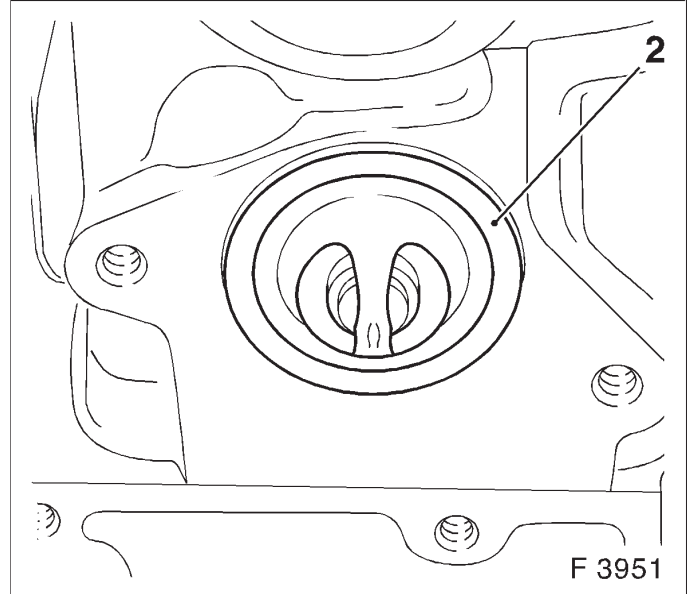
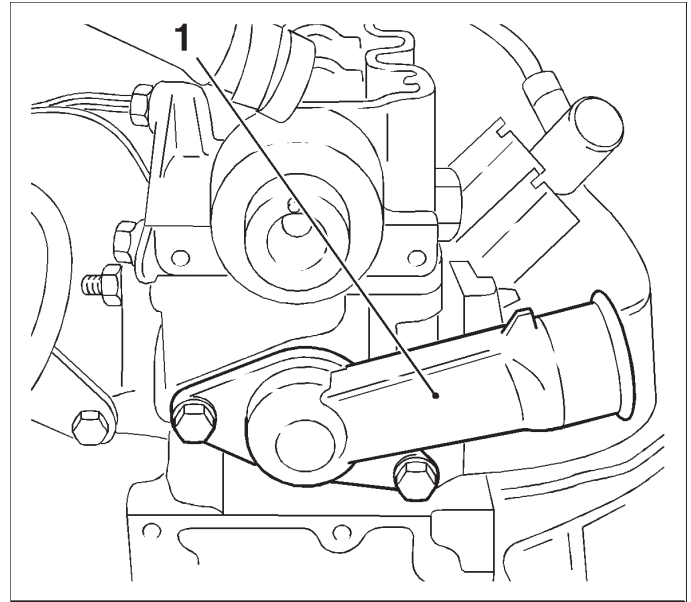

Install, Connect

Install rear toothed belt cover – see operation "Toothed Belt Cover – Rear, Remove and Install".

Install toothed belt tension roller – see operation "Toothed Belt Tension Roller, Remove and Install".

Install toothed belt – see operation "Toothed Belt, Remove and Install".

Install lower part of toothed belt cover – see operation "Toothed Belt Cover – Lower Part, Remove and Install".

Install ribbed V-belt tensioner – see operation "Ribbed V-belt Tensioner, Remove and Install".

Install ribbed V-belt – see operation "Ribbed V-belt, Remove and Install".

Install upper part of toothed belt cover – see operation "Toothed Belt Cover – Upper Part, Remove and Install".

Install air cleaner housing with air intake cover.

Attach coolant hose to thermostat housing.

Close coolant drain bolt.

Coolant Pump, Remove and Install

Remove, Disconnect

Open coolant drain bolt – collect escaping coolant.
 Remove air cleaner housing with air intake cover.
 Remove upper part of toothed belt cover – see operation "Toothed Belt Cover – Upper Part, Remove and Install".
 Remove ribbed V-belts – see operation "Ribbed V-belts, Remove and Install".
 Remove ribbed V-belt tensioner – see operation "Ribbed V-belt Tensioner, Remove and Install".
 Remove lower part of toothed belt cover – see operation "Toothed Belt Cover – Lower Part, Remove and Install".
 Remove toothed belt – see operation "Toothed Belt, Remove and Install".
 Remove toothed belt tension roller – see operation "Toothed Belt Tension Roller, Remove and Install".

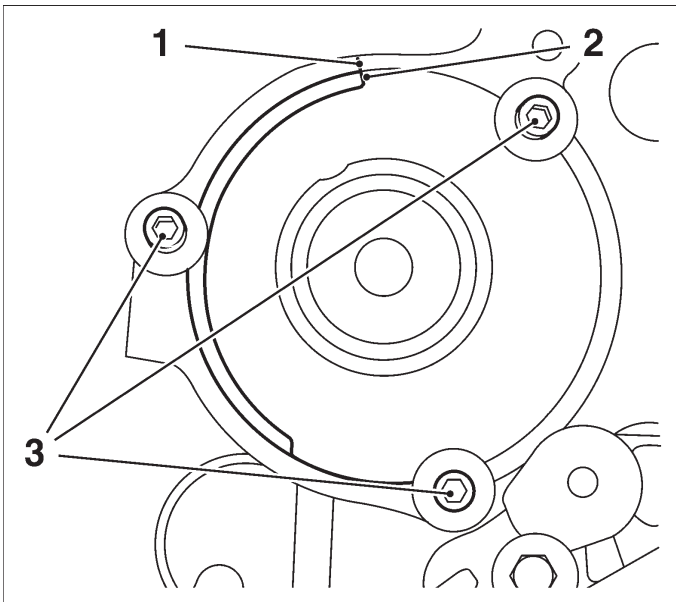

Remove, Disconnect

Remove rear toothed belt cover – see operation "Rear Toothed Belt Cover, Remove and Install". Remove fastening bolts (3) from coolant pump and remove coolant pump.

Clean

Remove gasket remnants and clean sealing surfaces.

Install, Connect

Before installing coolant pump, coat sealing surface (4) with silicon grease (white).
 Attach coolant pump with new seal ring to cylinder block – tightening torque 8 Nm / 6 lbf. ft.
 Mark (1) on cylinder block must align with mark (2) on coolant pump.
 Install rear toothed belt cover – see operation "Toothed Belt Cover – Rear, Remove and Install".

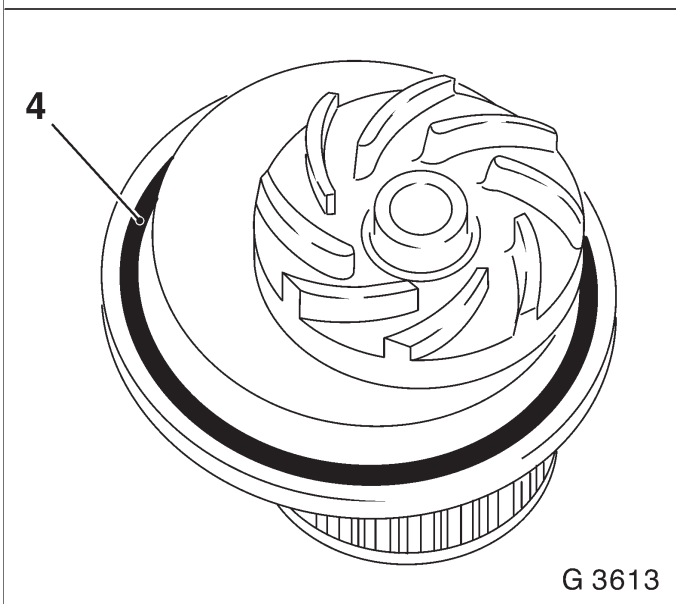

G 3613

Install, Connect

Install toothed belt tension roller – see operation "Toothed Belt Tension Roller, Remove and Install".

Install toothed belt – see operation "Toothed Belt, Remove and Install".

Install lower part of toothed belt cover – see operation "Toothed Belt Cover – Lower Part, Remove and Install".

Install ribbed V-belt tensioner – see operation "Ribbed V-belt Tensioner, Remove and Install".

Install ribbed V-belt – see operation "Ribbed V-belt, Remove and Install".

Install upper part of toothed belt cover – see operation "Toothed Belt Cover – Upper Part, Remove and Install".

Install air cleaner housing with air intake cover.

Close coolant drain bolt.

Inspect

Top up cooling system.

Coolant Pipe, Remove and Install**Note:**

For a clearer representation, illustration L 1286 shows the coolant pipe on removed engine.

Remove, Disconnect

Remove air intake cover with air intake hose.

Remove lower coolant hose (1) from radiator – place collection pan underneath.

Release coolant hose (3) and detach from heater core.

Remove coolant hose (5) from coolant compensation tank and coolant hose (2) from coolant pump connection.

Remove all requisite cable ties and clips from coolant pipe.

Detach or disconnect knock sensor wiring harness plug and odometer sensor – expose wiring harness.

Remove fastening bolt (4) and remove coolant pipe.

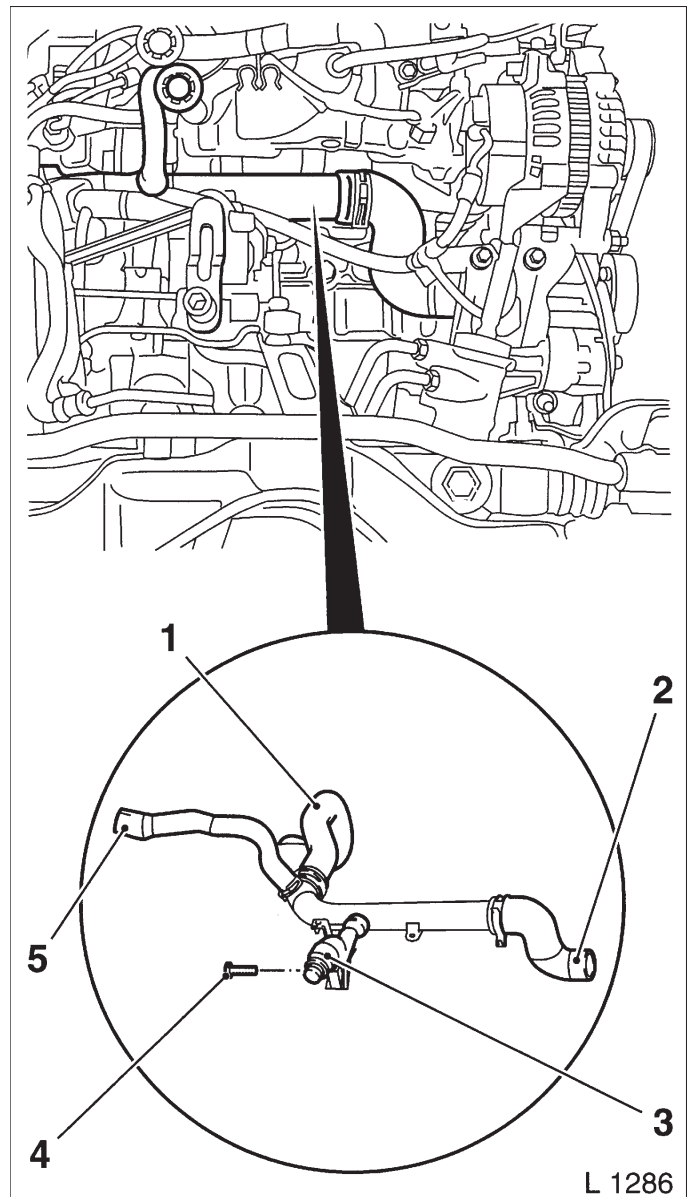

Install, Connect

Insert coolant pipe and attach to transmission – tightening torque 60 Nm / 44 lbf. ft.

Connect knock sensor wiring harness plug and odometer sensor – note cable routing.

Attach coolant hoses to coolant pump connection, coolant compensation tank and radiator – ensure correct hose positioning and seating.

Attach and lock coolant hose to heater core.

Attach cable ties and clips at original point.

Install air intake cover with air intake hose.

Inspect

Top up cooling system – see operations "Cooling System, Top Up and Bleed" and "Cooling System, Check for Leaks".

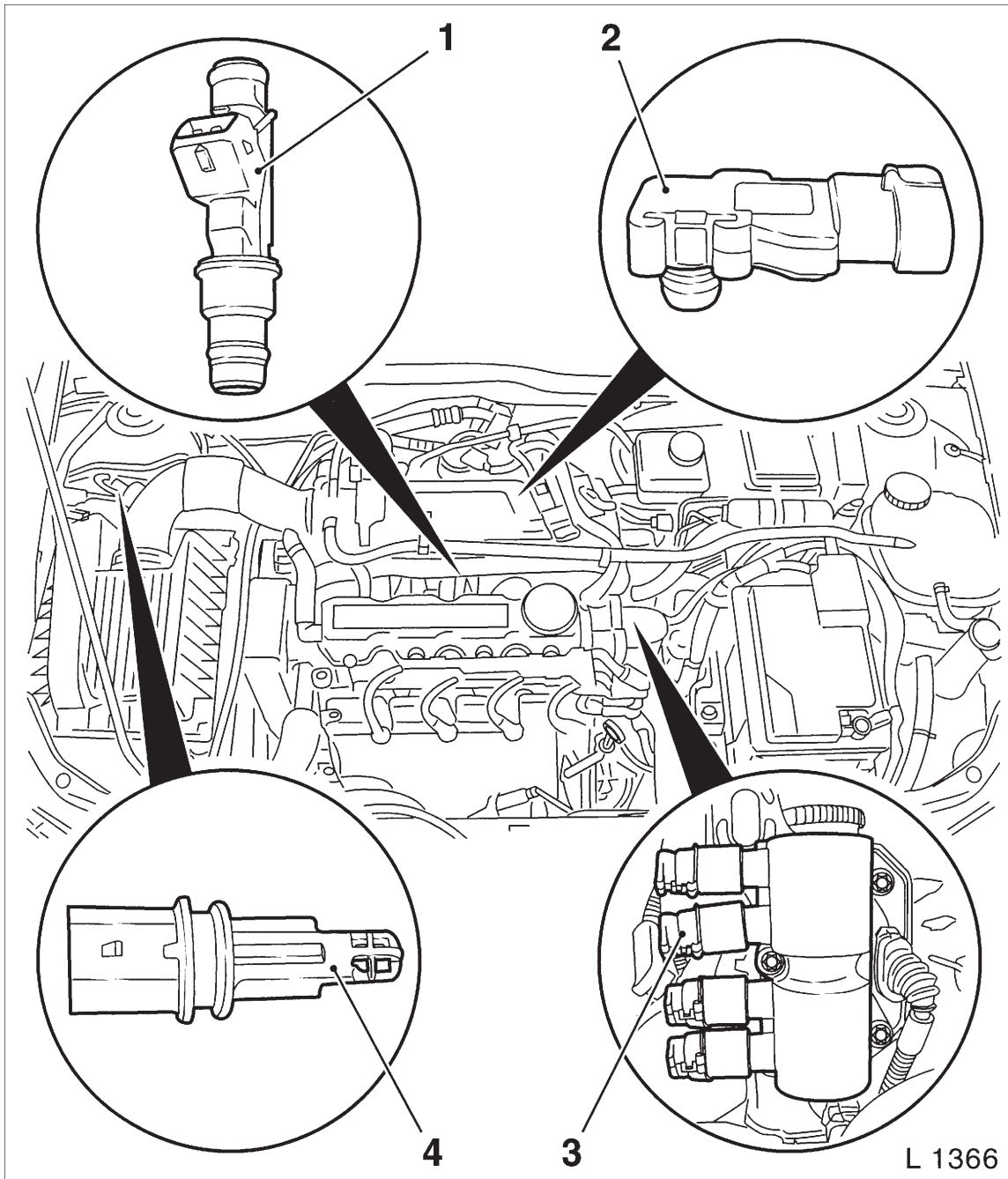

L 1366

Engine Compartment Survey (Continued)

- 1. Injectors
- 2. Intake manifold pressure sensor
- 3. DIS ignition module
- 4. Intake air temperature sensor

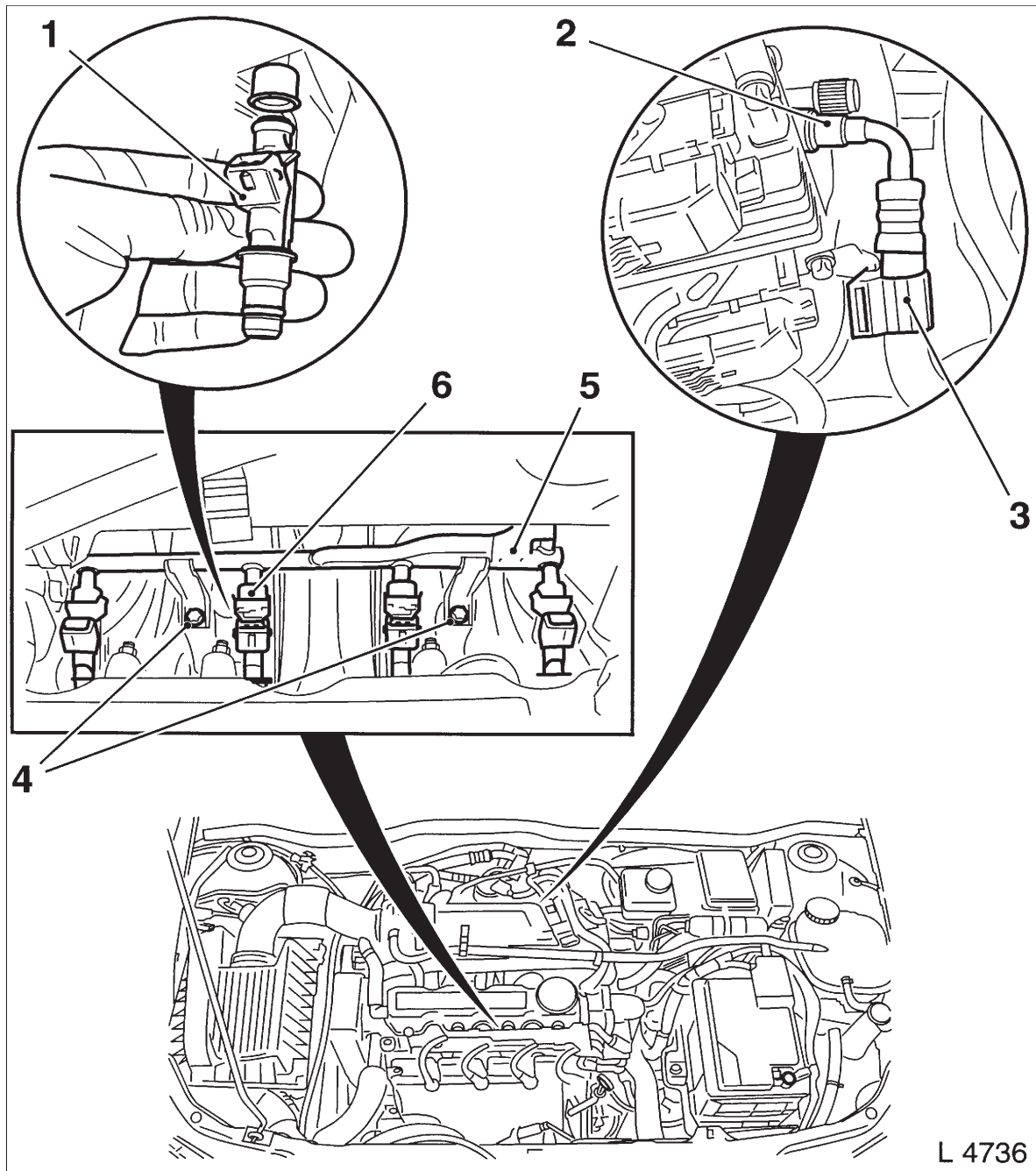

L 4736

Fuel Injector/Rail Remove

Remove, Disconnect

Detach fuel line (2) from fuel distributor pipe (5) and unclip from bracket (3).

Remove fuel distributor pipe fastening bolts (4) and pull fuel distributor pipe with injectors from intake manifold.

Remove each injector (1) from fuel distributor pipe remove spring clip (6).

Fuel Injector/Rail Install

Install, Connect

Insert injector in fuel distributor pipe with new seal rings – secure with spring clip.

Insert fuel distributor pipe with injectors in intake manifold and attach to intake manifold with fastening bolts – tightening torque 4 Nm / 3 lbf. ft.

Install, Connect

Attach fuel line to fuel distributor pipe and clip in bracket.

Connect wiring harness plugs to injectors and route wiring harness.

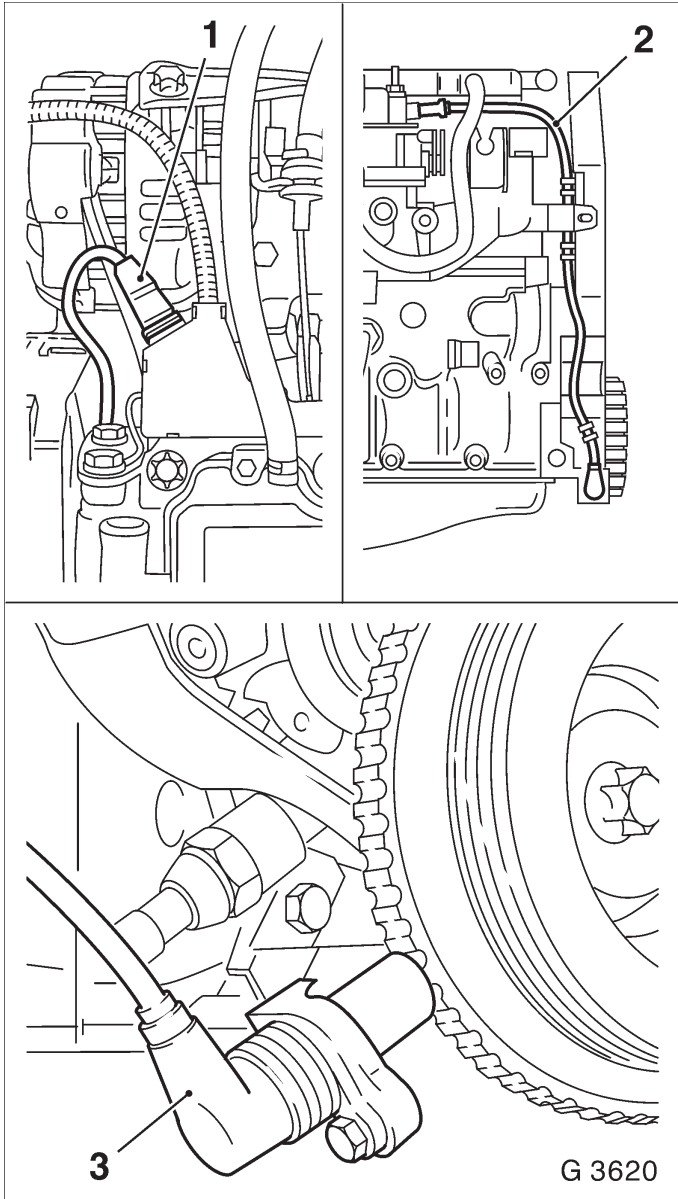

Crankshaft Position Sensor, Remove and Install

Remove, Disconnect

Remove air cleaner housing with air intake cover. Disconnect wiring harness plug for crankshaft pulse pickup (1). Remove cable for crankshaft pulse pickup (2) from the rear toothed belt cover. Remove crankshaft position sensor (3) from bracket.

Install, Connect

Attach crankshaft position sensor to bracket – 8 Nm / 6 lbf. ft. Insert crankshaft pulse pickup cable in rear toothed belt cover. Connect wiring harness plug for crankshaft position sensor – ensure that cable routing is correct. Install air cleaner housing with air intake cover.

Inspect

Check gap between crankshaft position sensor and reluctor ring – see operation "Gap between Crankshaft Position Sensor and Reluctor Ring."

Reference Gap Between Crankshaft Pulse Pickup and Increment Disc, Check

Measure

Measure distance between crankshaft position sensor and reluctor ring with feeler gauge.

Nominal value: 1,0 +/-0.7 mm.

With incorrect gap – replace bracket for crankshaft position sensor.

Tighten (Torque)

Crankshaft position sensor bracket to oil pump housing – 10 Nm / 7 lbf. ft.

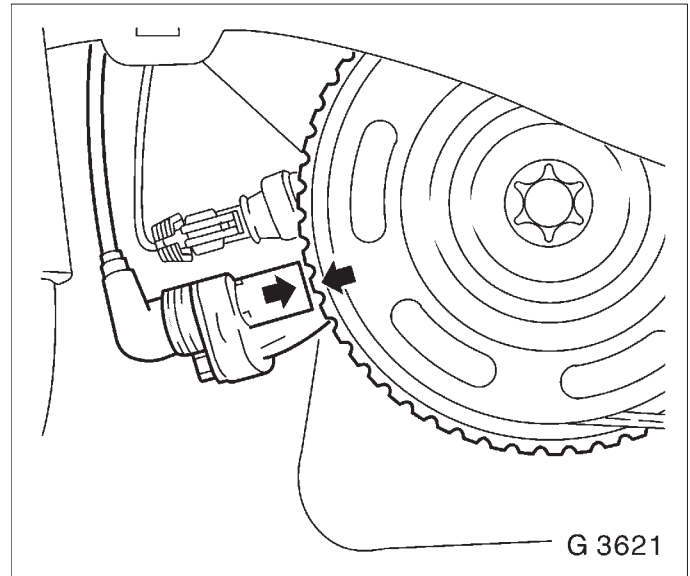

Special Service Tools

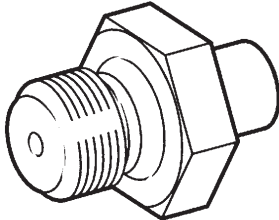
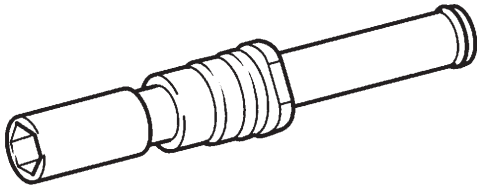
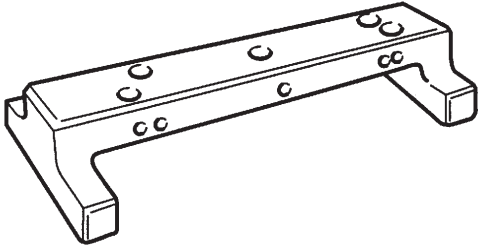
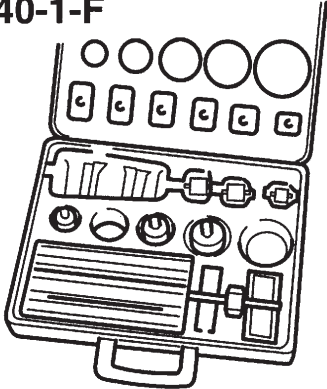
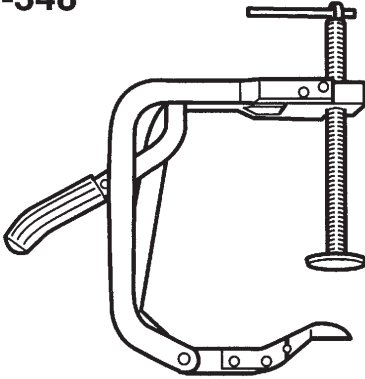
<p>KM-135</p> 	<p>KM-194-E</p> 
<p>KM-301</p> 	<p>KM-340-1-F</p> 
<p>KM-348</p> 	<p style="text-align: right;">L 2223</p>

KM-135 Adapter
To measure engine oil pressure in conjunction with KM-498-B

KM-194-E Spark Plug Key
To remove and install spark plugs, A/F 16 mm

KM-301 Gauge Bar
To check piston projection
KM-340-1-F Cutter Set

To mill, rework valve seats

KM-348 Spring Compressor
To compress valve springs, cylinder head removed

Special Service Tools (Continued)

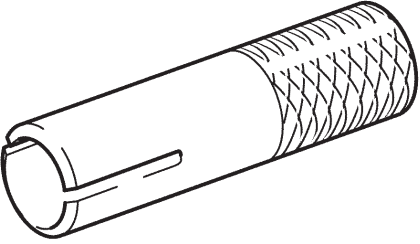
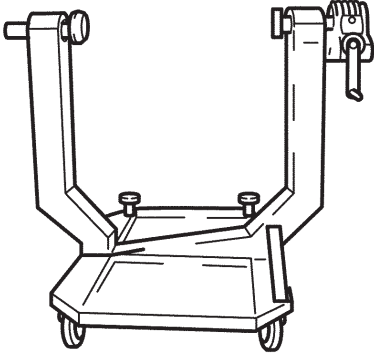
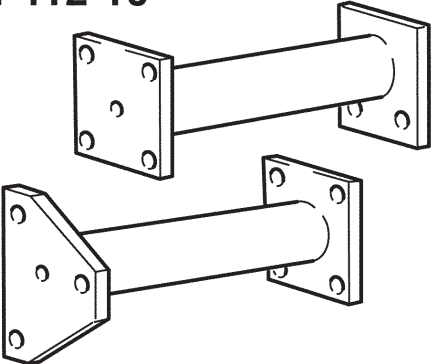
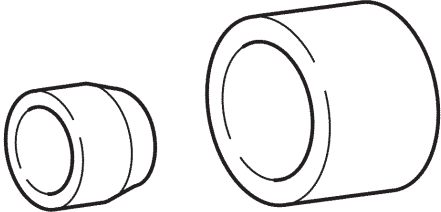
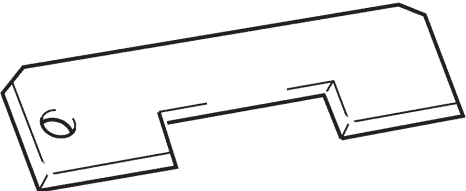
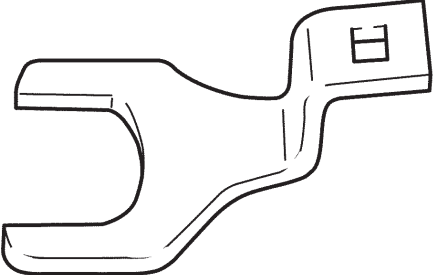
<p>KM-352</p> 	<p>KM-412</p> 
<p>KM-412-10</p> 	<p>KM-417</p> 
<p>KM-419</p> 	<p>KM-421-A</p>  <p style="text-align: right;">G 3692</p>

KM-352 Installer
To install valve stem sealing

KM-412 Engine Overhaul Stand
To hold removed engine

KM-412-10 Adapter
To hold engine in conjunction with KM-412

KM-417 Assembly Sleeves
To press crankshaft seal ring into oil pump housing

KM-419 Distance Gauge
To check valve stem projection

KM-421-A Adjusting Wrench
To adjust toothed belt tension

Special Service Tools (Continued)

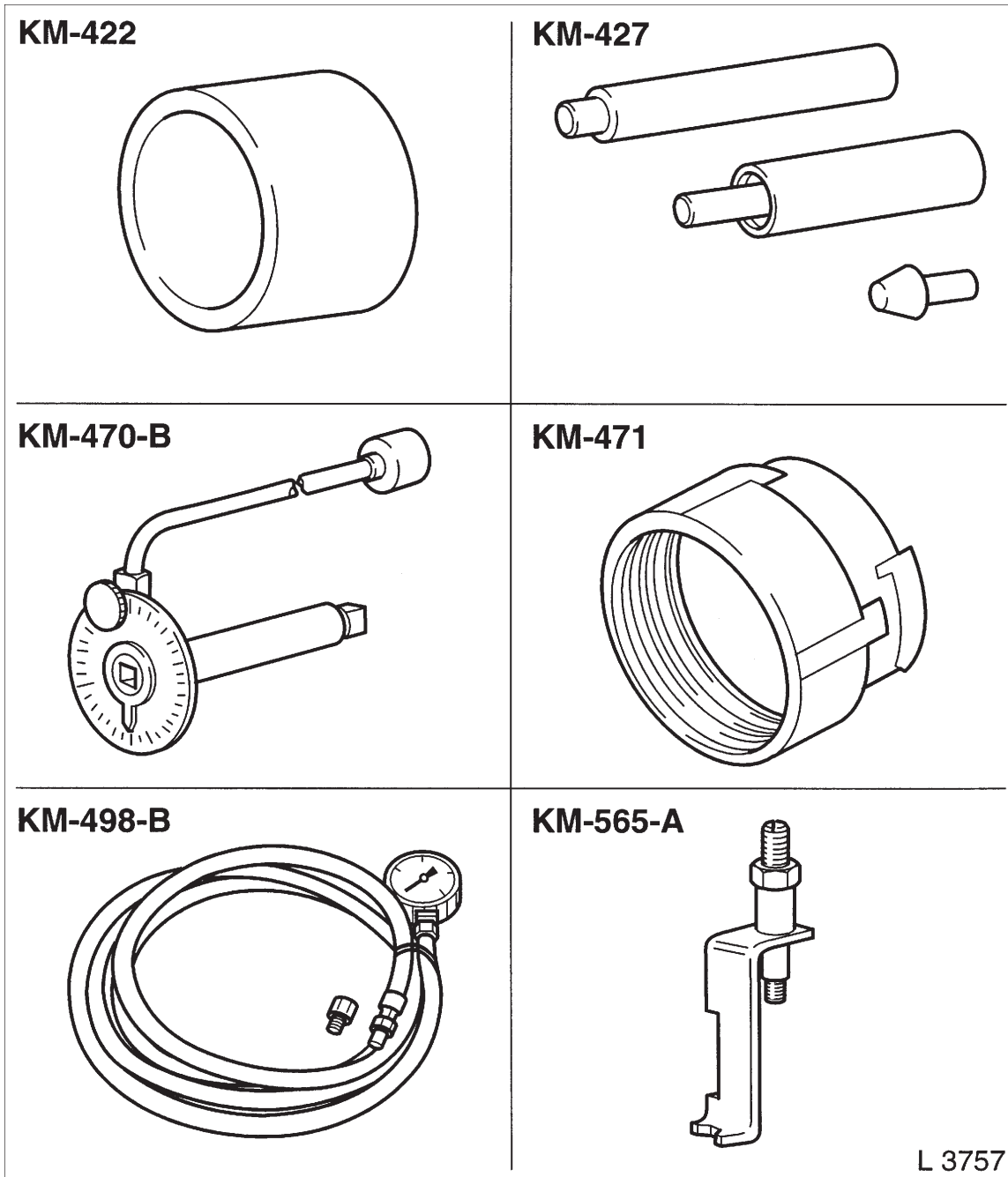

KM-422 Installer
To press seal ring in camshaft housing

KM-427 Remover / Installer
To install guide pins into engine block

KM-470-B Angular Torque Wrench
To tighten cylinder head bolts

KM-471 Adapter
To check pressurized cooling system in conjunction with cooling system tester

KM-498-B Oil pressure gauge
To check engine oil pressure in conjunction with KM-135

KM-565-A Remover / Installer
To remove and install rocker arms and valve play compensator

Special Service Tools (Continued)

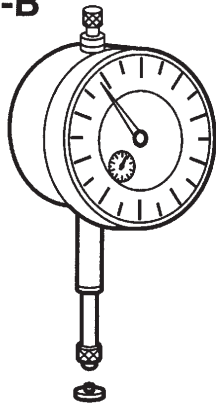
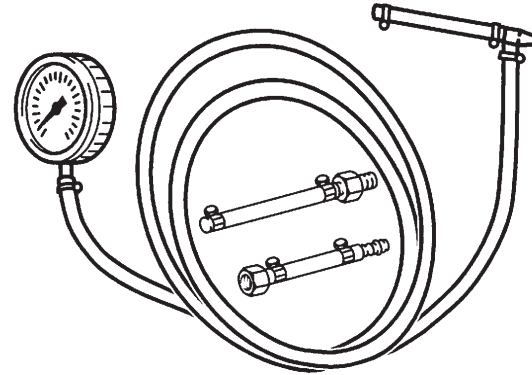
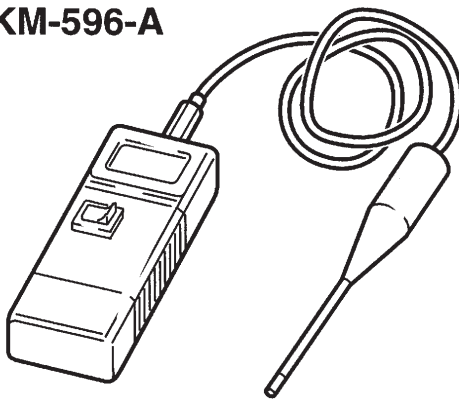
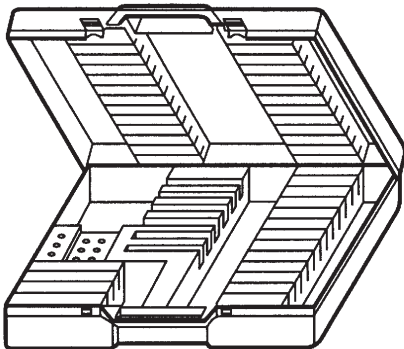
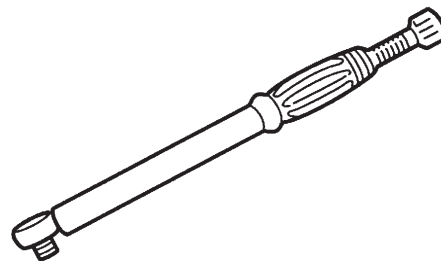
MKM-571-B**MKM-588-A****MKM-596-A****MKM-604-D****KM-609****MKM-610**

L 2224

MKM-571-B Dial Gauge
To measure piston projection

MKM-588-A Pressure Gauge
To check fuel pressure

MKM-596-A Temperature Gauge
To measure oil temperature, exhaust gas special test
(German AU)

MKM-604-D Torx Bit and Socket Set
To remove/install Torx bolts

KM-609 Electronic Kit I
Diagnosis of electric and electronic systems

MKM-610 Torque Wrench, 1/2''
Range 30 – 130 Nm / 22 – 96 lb. ft.

Special Service Tools (Continued)

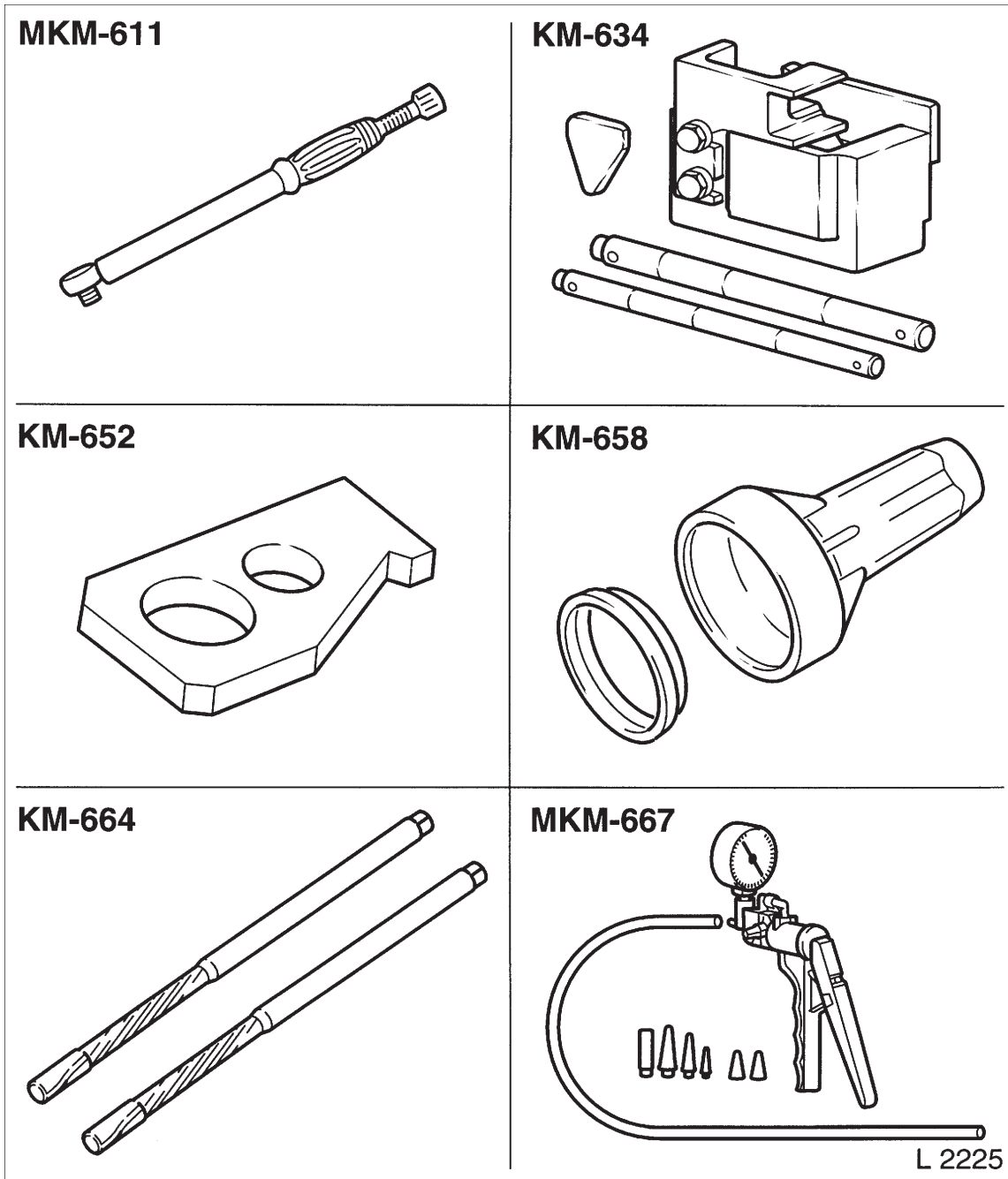

MKM-611 Torque Wrench, 3/8”
Range 10 – 60 Nm / 7 – 44 lb. ft.

KM-634 Remover / Installer
To remove/install piston pin

KM-652 Flywheel Holder
To lock flywheel/drive disc
KM-658 Installer

To install crankshaft rear seal ring

KM-664 Reamer Set 7 mm
Valve guide ream (j 7 mm)

MKM-667 Pressure and Vacuum Pump
To check for leaks in vacuum unit

Special Service Tools (Continued)

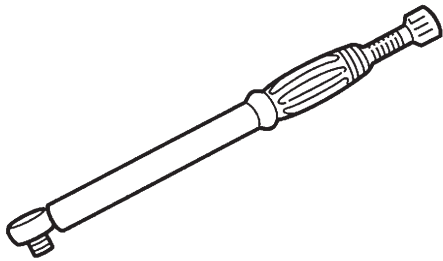
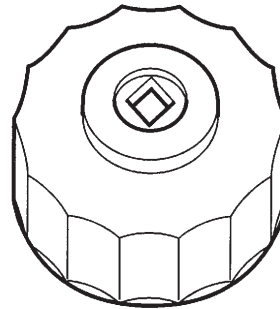
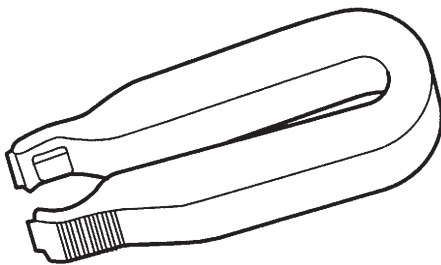
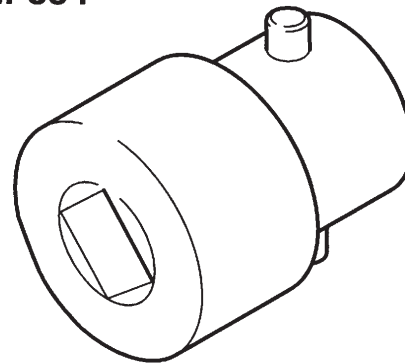
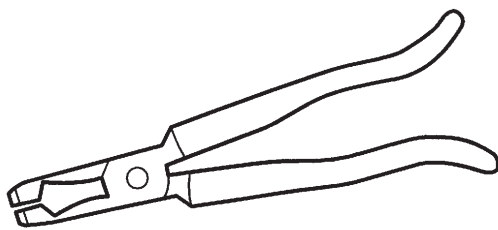
MKM-669**KM-726-A****KM-796-A****KM-834****KM-840**

L 6747

MKM-669 Torque Wrench, 1/2"
Range 50 – 300 Nm / 37 – 221 lbf. ft.

KM-726-A Oil Filter Wrench
To remove/install the oil filter

KM-796-A Remover
To open quick fittings for fuel lines

KM-834-A Remover / Installer
To remove and install heat sleeves

KM-840 Remover
To remove valve stem seal

Special Service Tools (Continued)

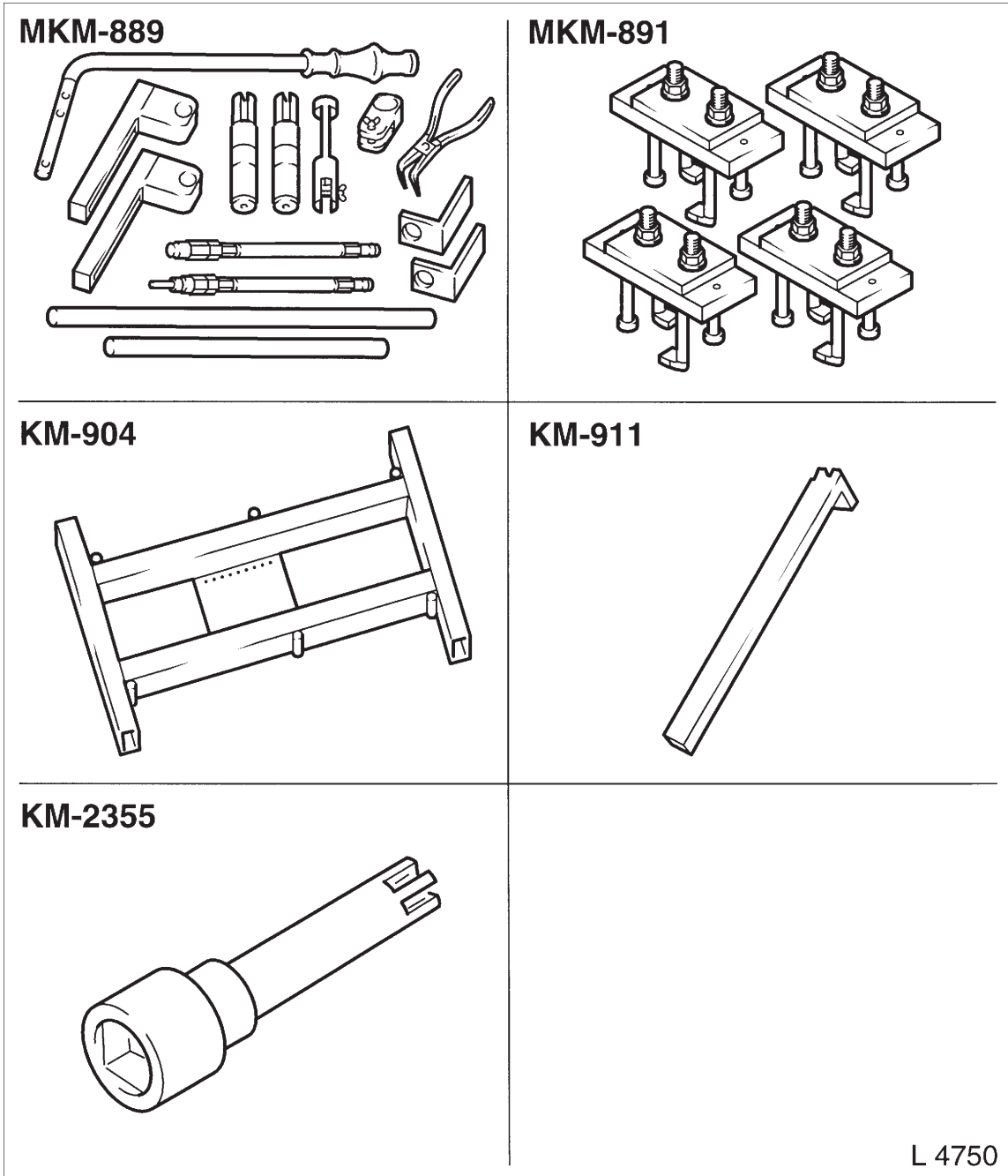

MKM-889 Automatic Valve Spring Lever
To remove/install the valve stem seals (cylinder head installed)

MKM-891 Valve Lifter Depressor
To remove/install camshaft (cylinder head installed)

KM-904 Base Frame
To remove and install various vehicle components with additional adapters

KM-911 Flywheel Holder
To lock flywheel/drive disc

KM-2355 Socket Wrench T55
To loosen/tighten cylinder head bolts

L 4750

Special Service Tools (Continued)

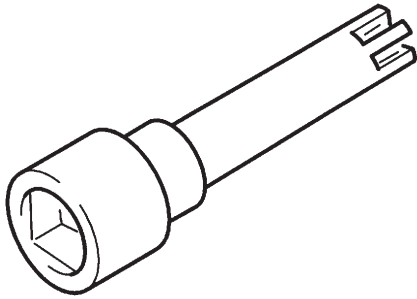
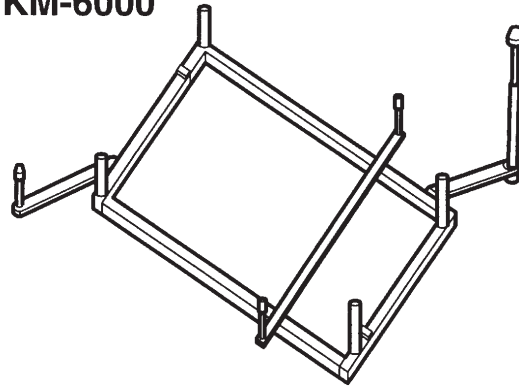
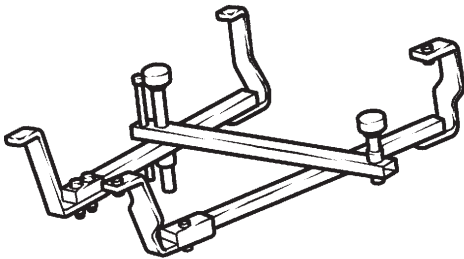
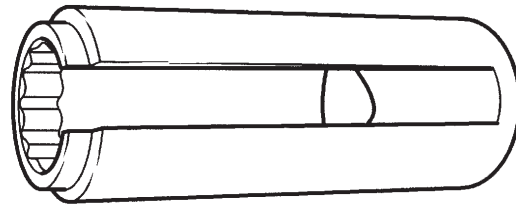
KM-2355**KM-6000****KM-6001-A****KM-6179****KM-J-34730-91**

L 4749

KM-6000 Centering Tool
To remove and install front axle in conjunction with KM-904

KM-6001-A Engine Mount
To align engine to body in conjunction with KM-6173

KM-6173 Engine Mount
To support engine on front axle body in conjunction with KM-6001-A

KM-6179 Remover / Installer
To remove and install oxygen sensor

KM-J-34730-91 Pressure Tester
To check fuel pressure

Sealants, Lubricants and Locking Compounds

Description	Applications	Catalogue Number	Part number
Surface sealant (green)	To install camshaft housing	15 03 170	90 542 114
Adhesive sealing compound (black)	To install oil pan, oil pump and 5th crankshaft bearing cap	15 03 295	90 485 251
MoS ₂ – lubricating paste (grey)	Lubricating paste for hydraulic valve lifter, cam follower and camshaft	19 48 565	90 018 024
Screw locking compound (red)	Locking compound for adhesion of screw connections	15 10 181	90 542 117

Sealants, Lubricants and Locking Compounds (Continued)

Description	Applications	Catalogue Number	Part number
Silicon grease (white)	To install seal rings	19 70 205	90 167 353
Special grease (black)	Installation of oxygen sensor	19 48 602	90 295 397
Assembly paste (white)	To install heat shield sleeves and front exhaust pipe (bolts)	19 48 569	90 513 210
Grease (brown)	Multi-purpose grease for alternator, starter, etc.	19 48 605	90 510 336

Technical Data

Specifications

Engine		Z 16 SE
No. of cylinders/layout		4 in line
No. of valves		8
Capacity	cm ³	1599
Bore diameter	mm	79
Stroke	mm	81.5
Power output	kW / rpm	62 / 5400
Torque	Nm / rpm	138 / 2600
Compression		9.6: 1

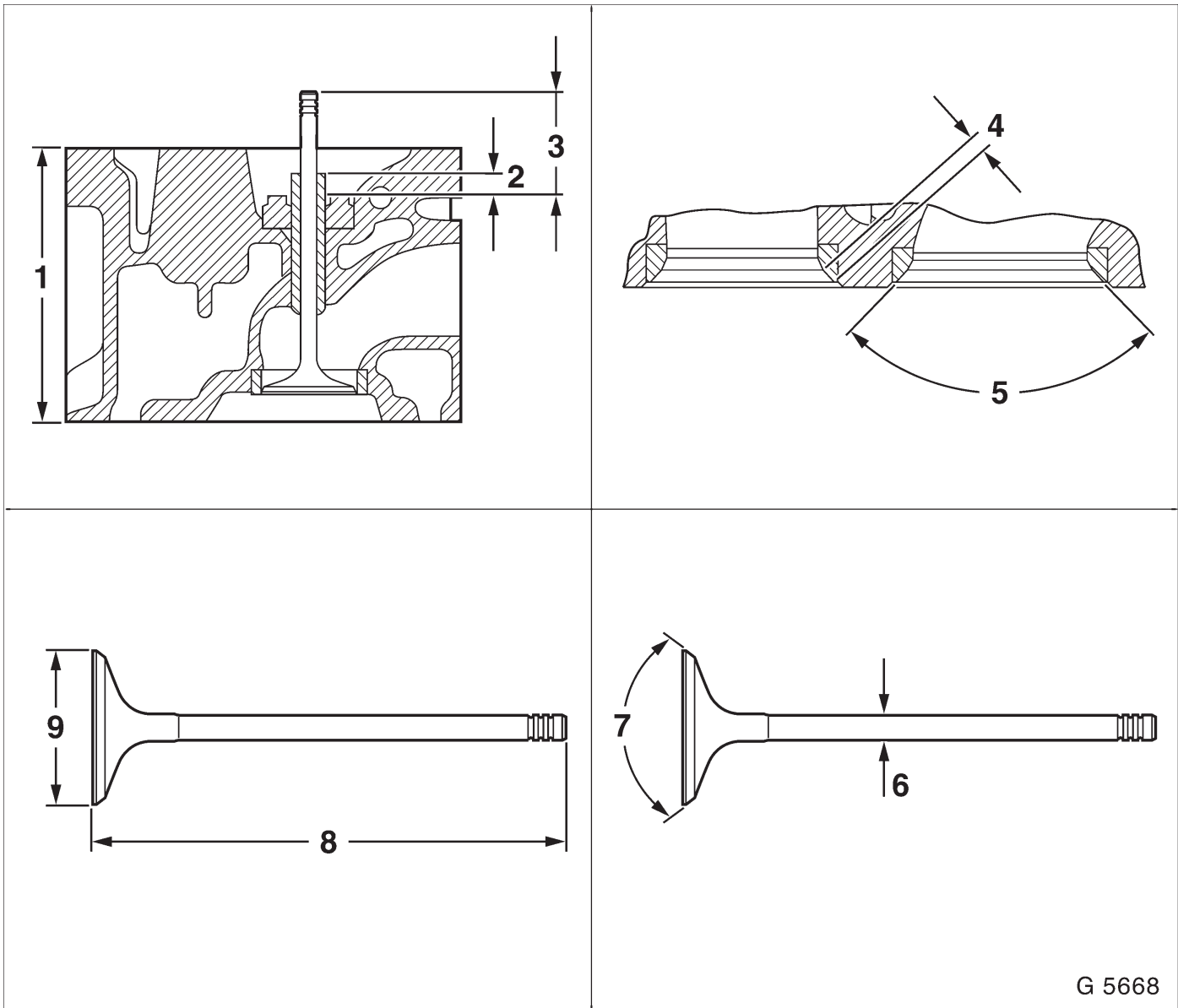

Cylinder Head

Illustration

- 1 Cylinder head height
- 2 Installation height of valve guide
- 3 Installation height of valve
- 4 Valve seat width in cylinder head
- 5 Valve seat angle in cylinder head
- 6 Valve stem diameter
- 7 Valve seat angle at valve
- 8 Valve length
- 9 Valve head – diameter

Cylinder Head (Continued)

Engine		1.6L
Cylinder head height ¹⁾	mm	95.90–96.10
Valve seat width in cylinder head		
Intake valve	mm	1.3–1.5
Exhaust valve	mm	1.6–1.8
Valve seat angle in cylinder head		90°
Valve guide inside diameter		
Standard size	mm	7.030–7.050
Oversize (0.075)	mm	7.105–7.125
Oversize (0.150)	mm	7.180–7.200
Length of valve guide		
Intake valve	mm	45.5
Exhaust valve	mm	45.5
Installation height of valve guide	mm	80.85–81.25
Installation height of valves	mm	13.75–14.35

Engine		1.6L
Valve length		
Standard size		
Intake valve (GM)	mm	101.65–101.95
Exhaust valve (GM)	mm	101.15–101.85
Oversize (0.075)		
Intake valve (GM K1)	mm	101.25–101.55
Exhaust valve (GM K1)	mm	100.75–101.45
Oversize (0.150)		
Intake valve (GM K2)	mm	101.25–101.55
Exhaust valve (GM K2)	mm	100.75–101.45
Valve stem		
Standard size		
Intake valve (GM)	mm	6.998–7.012
Exhaust valve (GM)	mm	6.978–6.992
Oversize (0.075)		
Intake valve (GMK1)	mm	7.073–7.087
Exhaust valve (GMK1)	mm	7.053–7.067
Oversize (0.150)		
Intake valve (GM K2)	mm	7.148–7.162
Exhaust valve (GM K2)	mm	7.128–7.142

Cylinder Head (Continued)

Engine		1.6L
Valve stem play		
Intake valve	mm	0.019–0.052
Exhaust valve	mm	0.038–0.072
Perm. runout of the valve stem	mm	0.03
∅Valve head		
Intake valve	mm	38.0
Exhaust valve	mm	31.0
Valve seat angle at valve head		92°
Valve rotator		
Intake valve		none
Exhaust valve		none

Engine		1.6L
Camshaft		
Cam lift		
Intake	mm	9.08
Exhaust	mm	9.99

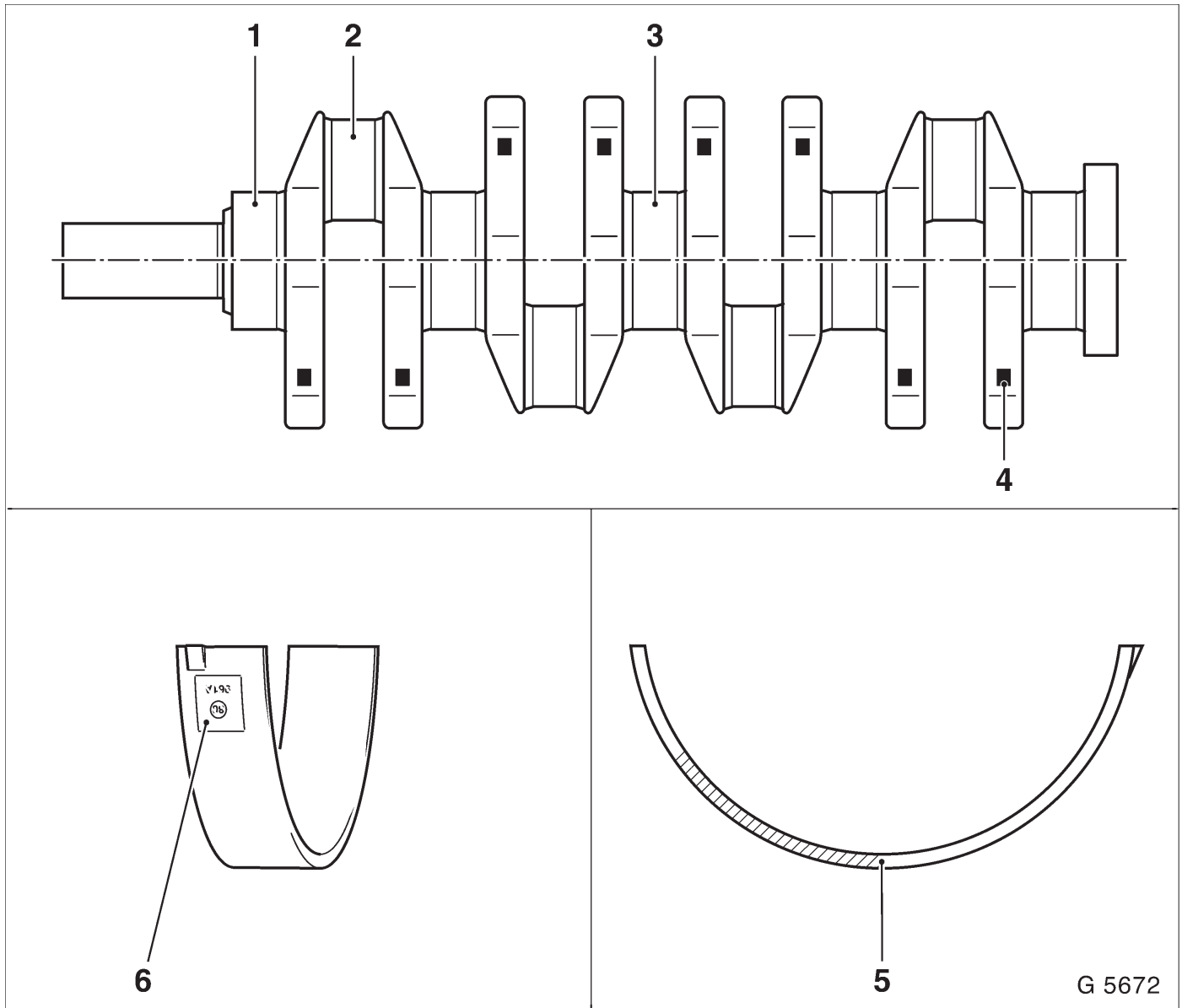

Crank Drive, Cylinder Block

Illustration

- 1 Main Bearing Journals
- 2 Con-rod bearing journal
- 3 Main Bearing Journals (Guide Bearing)
- 4 Crankshaft color code
- 5 Bearing shell color code
- 6 Bearing shell identification

Crank Drive, Cylinder Block (Continued)

Engine		1.6L	
Crankshaft dimensions		Main Bearing Journals 1 – 5	Color code
Standard size	mm	54.980–54.997	brown
	mm	54.980–54.997	green
Undersize (0.25)	mm	54.730–54.747	brown / blue
	mm	54.730–54.747	green / blue
Undersize (0.50)	mm	54.482–54.495	brown / white
	mm	54.482–54.495	green / white
		Con-rod bearing journal 1 – 4	
Standard size	mm	42.971–42.987	–
Undersize (0.25)	mm	42.721–42.737	blue
Undersize (0.50)	mm	42.471–42.487	white
		Wide main bearing journals ³ (guidebearing)	
Standard size	mm	26.000–26.052	–
Undersize (0.20)	mm	26.200–26.252	–
Undersize (0.40)	mm	26.400–26.452	

Crank Drive, Cylinder Block (Continued)

Engine		1.6L		
Crankshaft bearing 1, 2, 4, 5		Lower crankshaft bearing shell		
		Color code	Thickness	Code GM 400
Standard size	mm	brown	1.989–1.995	221 N
	mm	green	1.995–2.001	201 N
Undersize (0.25)	mm	brown / blue	2.114–2.120	222 A
	mm	green / blue	2.120–2.126	202 A
Undersize (0.50)	mm	brown / white	2.239–2.245	223 B
	mm	green / white	2.245–2.251	203 B
		Upper crankshaft bearing shell		
Standard size	mm	brown	1.989–1.995	221 N
	mm	green	1.995–2.001	201 N
Undersize (0.25)	mm	brown / blue	2.114–2.120	222 A
	mm	green / blue	2.120–2.126	202 A
Undersize (0.50)	mm	brown / white	2.239–2.245	223 B
	mm	green / white	2.245–2.251	203 B
Perm. crankshaft bearing clearance	mm	0.015–0.041		
Perm. crankshaft end clearance	mm	0.100–0.202		
Perm. out-of-round	mm	0.03		

Engine		1.6L		
Crankshaft bearing 3 (guide bearing)		Lower crankshaft bearing shell		
		Color code	Thickness	Code GM 400
Standard size	mm	brown	1.989–1.995	225 N
	mm	green	1.995–2.001	205 N
Undersize (0.25)	mm	brown / blue	2.114–2.120	225 A
	mm	green / blue	2.120–2.126	205 A
Undersize (0.50)	mm	brown / white	2.239–2.245	227 B
	mm	green / white	2.245–2.251	207 B
		Upper crankshaft bearing shell		
Standard size	mm	brown	1.989–1.995	225 N
	mm	green	1.995–2.001	205 N
Undersize (0.25)	mm	brown / blue	2.114–2.120	225 A
	mm	green / blue	2.120–2.126	205 A
Undersize (0.50)	mm	brown / white	2.239–2.245	227 B
	mm	green / white	2.245–2.251	207 B

Crank Drive, Cylinder Block (Continued)

Engine	1.6L			
3 wide main bearing journals (guide bearing)		Color code	Width	Code
Standard size	mm	green–brown	25.950–25.900	–
Undersize (0.25)	mm mm	brown/ blue green/ blue	25.950–26.100	–
Undersize (0.50)	mm mm	brown/ white green/ white	25.250–26.300	–

Engine	1.6L			
Con–rod bearing		Lower con–rod bearing shell		
		Color code	Thickness	Code GM 985.3
Standard size	mm	–	1.485–1.497	264N
Undersize (0.25)	mm	blue	1.610–1.622	265A
Undersize (0.50)	mm	white	1.735–1.747	265B
		Upper con–rod bearing shell		
Standard size	mm	–	1.485–1.497	264N
Undersize (0.25)	mm	blue	1.610–1.622	265A
Undersize (0.50)	mm	white	1.735–1.747	265B
Perm con–rod play	mm		0.019–0.071	

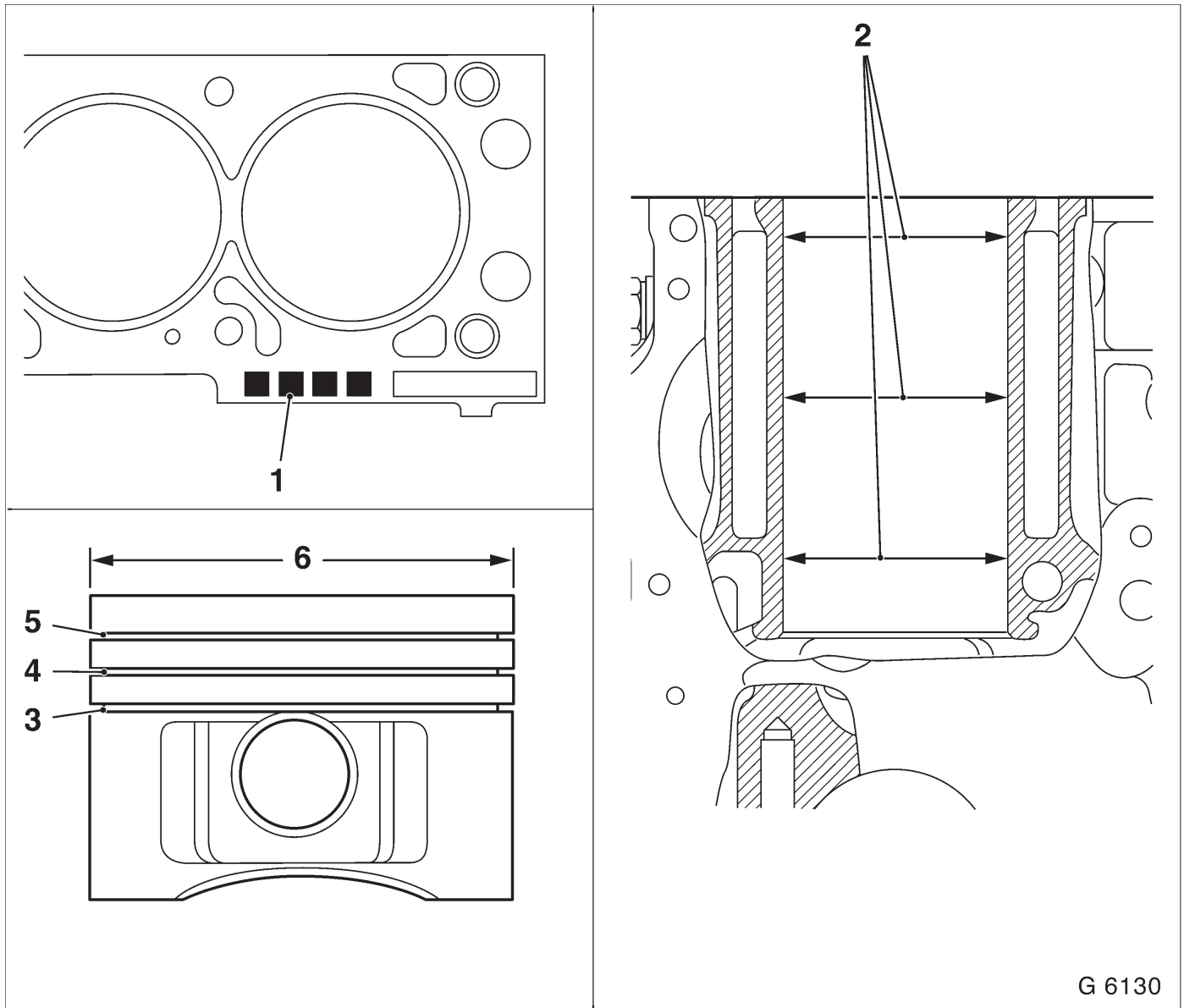

G 6130

Crank Drive, Cylinder Block (Continued)

Illustration

- 1 Index – identification of cylinder bore
- 2 Cylinder bore
- 3 Double bevelled ring with spiral-type expander
- 4 Tapered compression ring or double trapezoidal ring
- 5 Rectangular compression ring
- 6 Piston diameter

Crank Drive, Cylinder Block (Continued)

Engine		1.6L	
Cylinderbore			
Standard size			
Index	8	mm	78.975–78.985
Index	99	mm	78.985–78.995
Index	00	mm	78.995–79.005
Index	01	mm	79.005–79.015
Index	02	mm	79.015–79.025
Oversize ¹⁾			
Index	7 + 0.5	mm	79.465–79.475
Piston			
Standard size			
Index	8	mm	78.955–78.965
Index	99	mm	78.965–78.975
Index	00	mm	78.975–78.985
Index	01	mm	78.985–78.995
Index	02	mm	78.995–79.005
Oversize			
Index	7 + 0.5	mm	79.445–79.455
Piston clearance		mm	0.01–0.03
Piston projection		mm	0.4

1) After reboring the old index must be invalidated and the new oversizing index must be embossed.

Crank Drive, Cylinder Block (Continued)

Engine		1.6L
Piston rings		
Rectangular compression ring		
Height	mm	1.20
Gap	mm	0.30–0.50
Vertical play	mm	0.02–0.04
Tapered compression ring		
Height	mm	1.50
Gap	mm	0.30–0.50
Vertical play	mm	0.04–0.06
Oil scraper ring		
Height	mm	3.00
Gap	mm	0.40–1.40
Vertical play	mm	0.01–0.03
Ring gap distribution ¹⁾		120

- 1) Arrange gap of upper oil scraper ring 25 to 50 mm offset to the left and gap of the lower ring 25 to 50 mm offset to the right relative to the gap of the lower intermediate ring.

Engine		1.6L
Pistonpin		
Length	mm	55
Diameter	mm	17.997–18.000
Bearing		shrunk in con-rod
Clearance		
in piston	mm	0.009–0.012
in con-rod	mm	0

Engine Management

Engine		1.6L
Designation		Multec-S
Ignition sequence		1-3-4-2
Spark plugs		FLR 8 LDCU

Recommended Torque Values

	Nm
Starter to transmission	40
Starter to cylinder block	25
Exhaust manifold to cylinder head	22 ²⁾
Camshaft sensor fastening bolt to camshaft housing	16
DIS Ignition Module to camshaft housing carrier	8
Throttle body to intake manifold	9
Pressure plate to camshaft housing	8

- 1) Use new bolts.
- 2) Use new nut(s).

Recommended Torque Values (Continued)

	Nm
Dynamic oil level control to oil pan	8 ¹⁾
Intake manifold to cylinder head	22 ²⁾
Alternator to alternator support	35
Alternator to alternator shackle	20
Transmission to cylinder block	60
Alternator support to cylinder block	35
Engine damping block support to cylinder block	50
Crankshaft position sensor bracket to oil pump	10
Wiring harness bracket to intake manifold	20

- 1) Recut thread before reuse and insert bolts with screw locking compound (red). The installation time including the torque check is max. 10 min.
- 2) Use new nut(s).

Recommended Torque Values (Continued)

	Nm
Rear toothed belt cover to camshaft housing	6
Rear toothed belt cover to oil pump and camshaft housing	6
Heat shield to exhaust manifold	8
Crankshaft position sensor to bracket	8
Pulley/Reluctor ring to toothed belt drive gear	95 + 30° + 15° ¹⁾

- 1) Use new bolts.

	Nm
Wiring trough to cylinderhead	8
V-belt tensioner to alternator support	25
Knock sensor to cylinder block	20
Fuel distributor tube to intake manifold	4
Fuel supply and return line to throttle valve guards	15
Coolant pump to cylinder block	8
Coolant pipe to transmission	60
Coolant pipe to cylinder block	20
Crankshaft bearing cap to cylinder block	50 + 45° + 15° ¹⁾
Oxygen sensor to exhaust manifold	40

- 1) Use new bolts.

Recommended Torque Values (Continued)

	Nm
Alternator shackle to intake manifold	20
Camshaft housing cover to camshaft housing	9
Camshaft sprocket to camshaft	45
Oil drain bolt to oil pan	55
Oil pressure switch to oil pump	30

Recommended Torque Values (Continued)

	Nm
Oil filter to oil pump	15
Oil pump to cylinder block	10
Oil pump cover to oil pump	8
Oil intake pipe to oil pump	8 ¹⁾
Oil intake pipe to cylinder block	8
Oil baffle plate to oil pan	8
Oil pan to transmission	40
Oil pan to oil pump	10 ¹⁾
Oil pan to cylinder block	10 ¹⁾
Con-rod bearing cap to con-rod	25 + 30 ^{2) 3)}

- 1) Recut thread before reuse and insert bolts with screw locking compound (red). The installation time including the torque check is max. 10 min.
- 2) Use new nut(s).
- 3) Use new bolts.

Recommended Torque Values (Continued)

	Nm
Hose clamps for air intake hose	3.5
Flywheel to crankshaft	$35 + 30^1 + 15^1$
Coolant temperature sensor to intake manifold	20
Support to alternator and intake manifold	20
Thermostat housing to cylinder head	10
Carrier plate (DIS ignition module) to camshaft housing	12
Closure bolt, safety valve to oil pump	50
Front exhaust pipe to exhaust manifold (hex bolts)	35^2
Front exhaust pipe to exhaust manifold (hex nuts)	45^3

- 1) Use new bolts.
- 2) Insert bolts with mounting paste (white).
- 3) Use new nut(s).

	Nm
Toothed belt cover – upper part to rear toothed belt cover	4
Toothed belt cover, lower part to rear toothed belt cover	4
Toothed belt tension roller to oil pump	20
Spark plug to cylinder head	25
Cylinder head and camshaft housing to cylinder block	$25 + 60^1 + 60^1 + 60^1$ ²⁾

- 1) Insert new bolt with screw locking compound (red).
- 2) Use new bolts.

