

# KOHLER<sup>®</sup>

## POWER SYSTEMS





### INSTRUCTIONS

## Cart Kit PA-228578 Portable Generator Sets

This kit is used to convert full frame to carts on 3.5MM, 4MM, 5MM, 6MM, 5CM-HS, 6CM-HS, 3.5MBM, and 5MBM PowerPro portable models. The 3.5MBM must have the wrap-around frame kit (PA-239259) installed. No drilling is necessary to install the cart kit.

To make assembly of the cart to the wrap-around frame as easy as possible, the unit should be elevated with blocks at least 6 inches (152mm) off the floor. Refer to Figure 1 and parts list for location and identification of parts. Use the following procedure to install the kit.

 <b>WARNING</b>

<p><b>Hot engine and exhaust system. Can cause severe injury or death.</b></p> <p>Do not work on generator set until unit is allowed to cool.</p>

**Hot parts can cause severe injury or death.** Do not touch hot engine parts. An engine gets hot while running and exhaust system components get extremely hot.

### INSTALLATION

1. Stop generator set and allow to cool.
2. Support generator with blocks at least 6 inches (152 mm) off the floor.
3. Attach U-bolts (X-397-8) to frame using 0.344-in. ID plain washers (X-25-85), and nuts (supplied with U-bolts). Do not tighten nuts.
4. Slide axle (228576) between U-bolts and frame.
5. Place one 0.812-in. ID plain washer (X-25-29) on each end of axle.
6. Place wheels (239655) on each end of the axle.
7. Center axle so that there is an equal amount extending beyond each wheel. Tighten U-bolt nuts.
8. Place one 0.812-in. ID plain washer (X-25-29) on each end of the axle (outside of wheel).
9. Install one cotter pin (X-37-2) on each end of the axle and spread ends to secure.
10. Place one carrying handle (228575) against frame with bracket holes aligned on each side of horizontal frame bar.
11. Install two shoulder screws (230175) and 5/16-18 elastic stop hex nuts (X-101-16) in bracket holes. Nut should be positioned toward generator set.
12. Install one handle bracket (239661) with one shoulder screw (230175) and 5/16-18 elastic stop hex nut (X-101-16). Locate bracket as near to the bottom of the frame as possible.

#### NOTE

It may be necessary to use a pliers to squeeze the bracket together so that the hardware can be installed.

13. Repeat Steps 10-12 for the other carrying handle.
14. Tighten all hardware, as necessary, to firmly attach carrying handles to frame.
15. Remove generator set from blocks and place on level ground.
16. Slide handle grips (228579) onto carrying handle ends.
17. Install 7/8-in. plug buttons (X-301-8) in end of carrying handles.

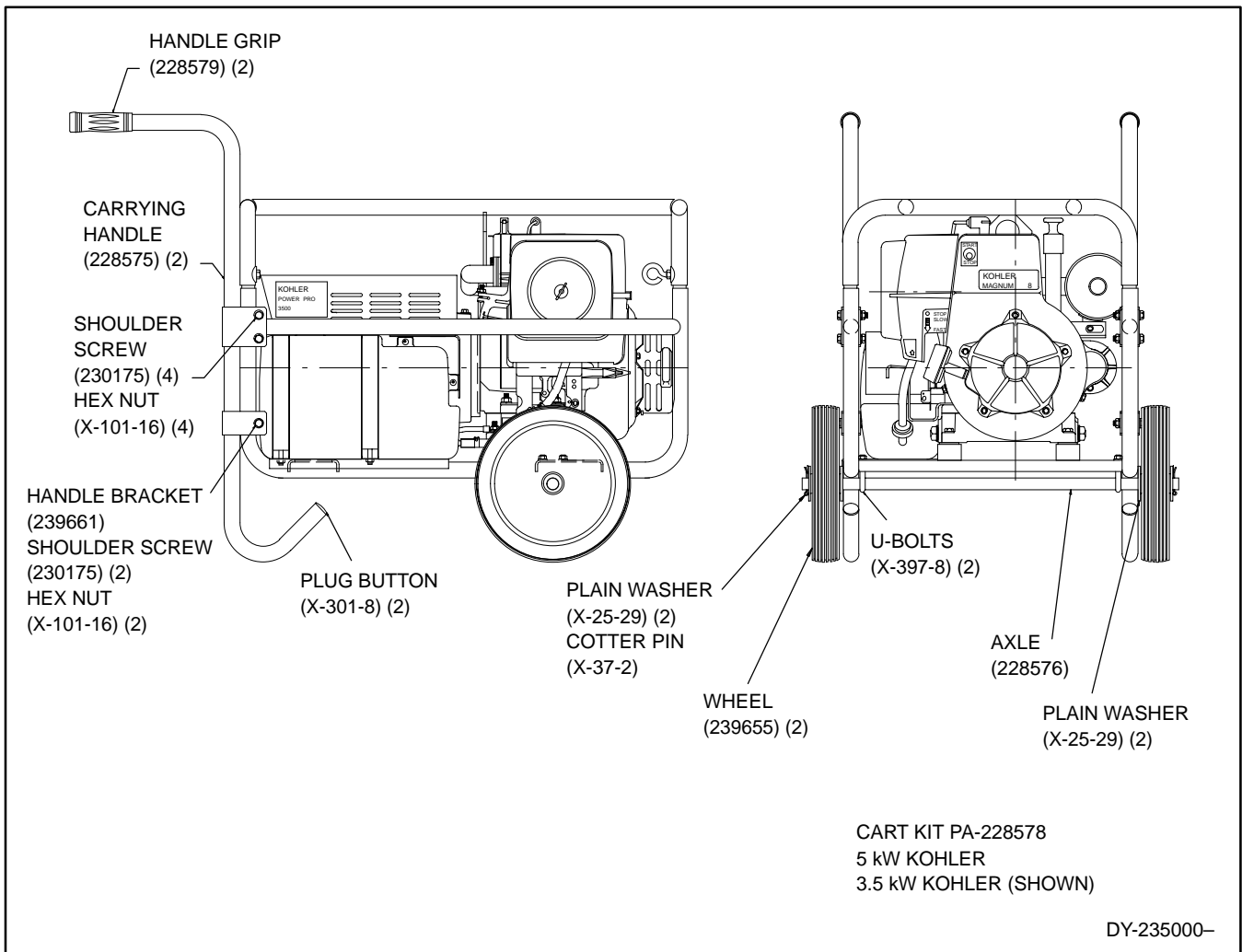

Figure 1. Cart Kit Installation

Parts List		
Kit PA-228578		
Qty.	Description	Part Number
6	Nut, hex, elastic stop, 5/16-18	X-101-16
4	Washer, plain, 0.812 x 1.469 x 0.134 in.	X-25-29
4	Washer, plain, 0.344 x 0.687 x 0.065 in.	X-25-85
2	Button, plug, 7/8 in.	X-301-8
2	Pin, cotter	X-37-2
2	U-bolt	X-397-8
2	Handle, carrying	228575
1	Axle	228576
2	Handle, grip	228579
6	Screw, shoulder	230175
2	Wheel	239655
2	Bracket, handle	239661