

SERVICE BULLETIN

Original Issue Date: 11/14

Model: 8/10/12RESV(L)

Market: Residential/Commercial

Subject: Enclosure Hole Alignment with Mounting Pad,
GM92228-KP1-QS, GM92228-KP2-QS

Introduction

To align the holes in the 8/10/12RESV(L) enclosures with the threaded inserts in the mounting pad, the enclosure holes may need to be increased in size. Before enlarging the holes, obtain four washers required for the enlarged hole size.

Follow the instructions and safety precautions in this service bulletin to ensure that the hole alignment is accurate. Refer to the mounting pad installation instructions, TT-1619, as needed for additional information.

Special Tools Needed

- Drill
- 19/32 in. drill bit
- Metal File
- Washers, Qty. 4: 10.5 mm ID x 20.0 mm OD x 2 mm thick, zinc plated
Kohler Part Number: **M125A-10-80**
- **GM84772** touch-up paint bottle or **GM84771** touch-up paint spray can

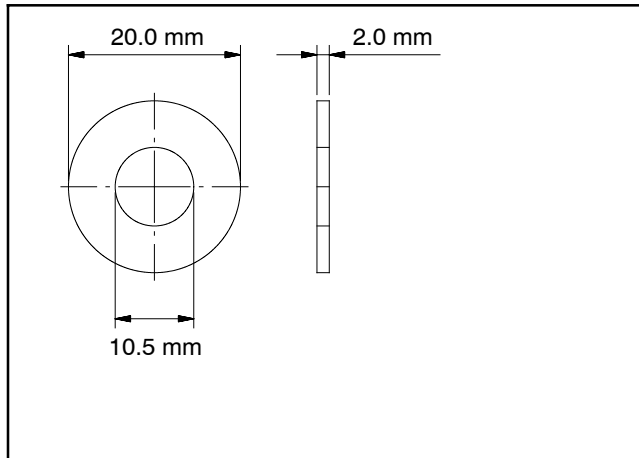

Figure 1-1 M125A-10-80 Washer Dimensions

Safety Precautions

WARNING
<p>Unbalanced and elevated weight. Improper lifting can cause severe injury or death and equipment damage.</p> <p>Do not lift the generator set from the engine or alternator eyes. Never stand under a unit being lifted. Always maintain a safe distance from the unit being lifted. See the lifting instructions in the installation manual that was provided with the unit.</p>

Installation Procedure

- 1.1 Use a 19/32 in. drill bit to enlarge the existing holes in the enclosure base.

Note: If the holes are not large enough, use the drill bit to carefully enlarge the holes further. Use extreme care to avoid damaging the enclosure base.

- 1.2 File any burrs and cover exposed metal with touch-up paint.

- 1.3 Align the enclosure with the mounting pad inserts.

- 1.4 Use the four bolts that come with the concrete pad and **M125A-10-80** washers to secure the generator to the mounting pad.

Note: Place the washer between the bolt head and the enclosure base.

Routing	Service Manager	Sales Manager	Parts Manager	Technician No. 1	Technician No. 2	Technician No. 3	Return This to
Initial Here							

KOHLER CO., Kohler, Wisconsin 53044 USA
Phone 920-457-4441, Fax 920-459-1646
For the nearest sales and service outlet in the
US and Canada, phone 1-800-544-2444
KOHLERPower.com

Kohler Power Systems
Asia Pacific Headquarters
7 Jurong Pier Road
Singapore 619159
Phone (65) 6264-6422, Fax (65) 6264-6455

Availability is subject to change without notice. Kohler Co. reserves the right to change the design or specifications without notice and without any obligation or liability whatsoever. Contact your local Kohler® generator set distributor for availability.

© 2014 by Kohler Co. All rights reserved.