

# Operation

## Residential/Commercial Generator Sets

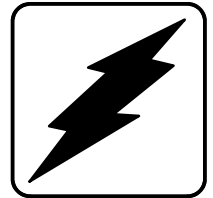

Models:

**8.5RES**

**12RES**

Controller:

Advanced Digital Control (ADC 2100)

**KOHLER**<sup>®</sup>  
POWER SYSTEMS

**ISO 9001**  
**KOHLER**  
POWER SYSTEMS  
NATIONALLY REGISTERED

TP-6331 5/04

---

**California Proposition 65**

**⚠ WARNING**

Engine exhaust from this product contains chemicals known to the State of California to cause cancer, birth defects, or other reproductive harm.

---

**Product Identification Information**

---

Product identification numbers determine service parts. Record the product identification numbers in the spaces below immediately after unpacking the products so that the numbers are readily available for future reference. Record field-installed kit numbers after installing the kits.

**Generator Set Identification Numbers**

Record the product identification numbers from the generator set nameplate(s).

Model Designation \_\_\_\_\_

Specification Number \_\_\_\_\_

Serial Number \_\_\_\_\_

<b>Accessory Number</b>	<b>Accessory Description</b>
-------------------------	------------------------------

_____	_____
_____	_____
_____	_____
_____	_____
_____	_____
_____	_____
_____	_____
_____	_____
_____	_____
_____	_____
_____	_____
_____	_____
_____	_____
_____	_____
_____	_____
_____	_____
_____	_____
_____	_____
_____	_____
_____	_____
_____	_____
_____	_____
_____	_____
_____	_____
_____	_____
_____	_____

**Controller Identification**

Record the controller description from the generator set operation manual, spec sheet, or sales invoice.

Controller Description \_\_\_\_\_

**Engine Identification**

Record the product identification information from the engine nameplate.

Manufacturer \_\_\_\_\_

Model Designation \_\_\_\_\_

Serial Number \_\_\_\_\_

# Table of Contents

<b>Product Identification Information</b> .....	<b>Inside front cover</b>
<b>Safety Precautions and Instructions</b> .....	<b>I</b>
<b>Introduction</b> .....	<b>i</b>
<b>Service Assistance</b> .....	<b>ii</b>
<b>Section 1 Features</b> .....	<b>1</b>
1.1 Specifications .....	1
1.2 Generator .....	1
1.3 Engine .....	1
1.4 Advanced Digital Control .....	1
1.5 Generator Set Components .....	2
<b>Section 2 Operation</b> .....	<b>3</b>
2.1 Prestart Checklist .....	3
2.2 Exercising Generator Set .....	3
2.3 Generator Set Operation .....	3
2.3.1 Controls and Indicators .....	4
2.3.2 Starting Generator Set .....	4
2.3.3 Stopping Generator Set .....	4
2.4 Fault Shutdowns .....	5
2.4.1 Resetting Controller after a Fault Shutdown .....	6
2.5 Continuous Power Mode .....	6
2.6 Battery Charger .....	7
2.6.1 Battery Charger Operation .....	7
<b>Section 3 Scheduled Maintenance</b> .....	<b>9</b>
3.1 Routine Maintenance .....	9
3.2 Service Schedule .....	10
3.3 Lubrication System .....	11
3.3.1 Low Oil Pressure Shutdown .....	11
3.3.2 Oil Check .....	11
3.3.3 Engine Oil Recommendation .....	11
3.3.4 Oil Change Procedure .....	11
3.4 Spark Plugs .....	12
3.5 Air Cleaner Element and Precleaner .....	12
3.5.1 Precleaner Service .....	12
3.5.2 Paper Element Service .....	13
3.6 Cooling System .....	14
3.7 Exhaust System .....	14
3.8 Battery .....	14
3.9 Battery Charger .....	15
3.10 Circuit Protection .....	16
3.10.1 Line Circuit Breaker .....	16
3.10.2 Fuses .....	16
3.11 Storage Procedure .....	16
3.11.1 Lubricating System .....	16
3.11.2 Fuel System .....	16
3.11.3 Cylinder Lubrication .....	17
3.11.4 Exterior Preparation .....	17
3.11.5 Battery .....	17

# Table of Contents, continued

---

<b>Section 4 Troubleshooting</b> .....	<b>19</b>
4.1 Introduction .....	19
4.2 Generator Set Troubleshooting .....	19
4.3 Fault Codes .....	20
4.4 Troubleshooting .....	20
4.5 Battery Charger Troubleshooting .....	20
Appendix A Abbreviations .....	A-1

# Safety Precautions and Instructions

**IMPORTANT SAFETY INSTRUCTIONS.** Electromechanical equipment, including generator sets, transfer switches, switchgear, and accessories, can cause bodily harm and pose life-threatening danger when improperly installed, operated, or maintained. To prevent accidents be aware of potential dangers and act safely. Read and follow all safety precautions and instructions. **SAVE THESE INSTRUCTIONS.**

This manual has several types of safety precautions and instructions: Danger, Warning, Caution, and Notice.

## DANGER

Danger indicates the presence of a hazard that **will cause severe personal injury, death, or substantial property damage.**

## WARNING

Warning indicates the presence of a hazard that **can cause severe personal injury, death, or substantial property damage.**

## CAUTION

Caution indicates the presence of a hazard that **will or can cause minor personal injury or property damage.**

## NOTICE

Notice communicates installation, operation, or maintenance information that is safety related but not hazard related.

Safety decals affixed to the equipment in prominent places alert the operator or service technician to potential hazards and explain how to act safely. The decals are shown throughout this publication to improve operator recognition. Replace missing or damaged decals.

## Accidental Starting

### WARNING

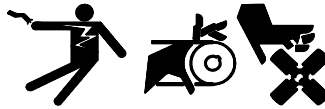

#### **Accidental starting. Can cause severe injury or death.**

Disconnect the battery cables before working on the generator set. Remove the negative (-) lead first when disconnecting the battery. Reconnect the negative (-) lead last when reconnecting the battery.

**Disabling the generator set. Accidental starting can cause severe injury or death.** Before working on the generator set or connected equipment, disable the generator set as follows: (1) Move the generator set master switch to the OFF position. (2) Disconnect the power to the battery charger. (3) Remove the battery cables, negative (-) lead first. Reconnect the negative (-) lead last when reconnecting the battery. Follow these precautions to prevent starting of the generator set by an automatic transfer switch, remote start/stop switch, or engine start command from a remote computer.

## Battery

### WARNING



#### **Sulfuric acid in batteries. Can cause severe injury or death.**

Wear protective goggles and clothing. Battery acid may cause blindness and burn skin.

### WARNING



#### **Explosion. Can cause severe injury or death. Relays in the battery charger cause arcs or sparks.**

Locate the battery in a well-ventilated area. Isolate the battery charger from explosive fumes.



**Battery electrolyte is a diluted sulfuric acid. Battery acid can cause severe injury or death.** Battery acid can cause blindness and burn skin. Always wear splashproof safety goggles, rubber gloves, and boots when servicing the battery. Do not open a sealed battery or mutilate the battery case. If battery acid splashes in the eyes or on the skin, immediately flush the affected area for 15 minutes with large quantities of clean water. Seek immediate medical aid in the case of eye contact. Never add acid to a battery after placing the battery in service, as this may result in hazardous spattering of battery acid.

**Battery acid cleanup. Battery acid can cause severe injury or death.** Battery acid is electrically conductive and corrosive. Add 500 g (1 lb.) of bicarbonate of soda (baking soda) to a container with 4 L (1 gal.) of water and mix the neutralizing solution. Pour the neutralizing solution on the spilled battery acid and continue to add the neutralizing solution to the spilled battery acid until all evidence of a chemical reaction (foaming) has ceased. Flush the resulting liquid with water and dry the area.

**Battery gases. Explosion can cause severe injury or death.** Battery gases can cause an explosion. Do not smoke or permit flames or sparks to occur near a battery at any time, particularly when it is charging. Do not dispose of a battery in a fire. To prevent burns and sparks that could cause an explosion, avoid touching the battery terminals with tools or other metal objects. Remove all jewelry before servicing the equipment. Discharge static electricity from your body before touching batteries by first touching a grounded metal surface away from the battery. To avoid sparks, do not disturb the battery charger connections while the battery is charging. Always turn the battery charger off before disconnecting the battery connections. Ventilate the compartments containing batteries to prevent accumulation of explosive gases.

**Battery short circuits. Explosion can cause severe injury or death.** Short circuits can cause bodily injury and/or equipment damage. Disconnect the battery before generator set installation or maintenance. Remove all jewelry before servicing the equipment. Use tools with insulated handles. Remove the negative (-) lead first when disconnecting the battery. Reconnect the negative (-) lead last when reconnecting the battery. Never connect the negative (-) battery cable to the positive (+) connection terminal of the starter solenoid. Do not test the battery condition by shorting the terminals together.

## Engine Backfire/Flash Fire



 <b>WARNING</b>

<p><b>Fire.</b>  <b>Can cause severe injury or death.</b></p> <p>Do not smoke or permit flames or sparks near fuels or the fuel system.</p>

**Servicing the air cleaner. A sudden backfire can cause severe injury or death.** Do not operate the generator set with the air cleaner removed.

**Servicing the fuel system. A flash fire can cause severe injury or death.** Do not smoke or permit flames or sparks near the carburetor, fuel line, fuel filter, fuel pump, or other potential sources of spilled fuels or fuel vapors. Catch fuels in an approved container when removing the fuel line or carburetor.

**Combustible materials. A fire can cause severe injury or death.** Generator set engine fuels and fuel vapors are flammable and explosive. Handle these materials carefully to minimize the risk of fire or explosion. Equip the compartment or nearby area with a fully charged fire extinguisher. Select a fire extinguisher rated ABC or BC for electrical fires or as recommended by the local fire code or an authorized agency. Train all personnel on fire extinguisher operation and fire prevention procedures.

## Exhaust System

 <b>WARNING</b>

<p><b>Carbon monoxide.</b>  <b>Can cause severe nausea, fainting, or death.</b></p> <p>The exhaust system must be leakproof and routinely inspected.</p>

**Generator set operation. Carbon monoxide can cause severe nausea, fainting, or death.** Carbon monoxide is an odorless, colorless, tasteless, nonirritating gas that can cause death if inhaled for even a short time. Avoid breathing exhaust fumes when working on or near the generator set. Never operate the generator set inside a building. Never operate the generator set where exhaust gas could seep inside or be drawn into a potentially occupied building through windows, air intake vents, or other openings.

**Carbon monoxide symptoms. Carbon monoxide can cause severe nausea, fainting, or death.** Carbon monoxide is a poisonous gas present in exhaust gases. Carbon monoxide poisoning symptoms include but are not limited to the following:

- Light-headedness, dizziness
- Physical fatigue, weakness in joints and muscles
- Sleepiness, mental fatigue, inability to concentrate or speak clearly, blurred vision
- Stomachache, vomiting, nausea

If experiencing any of these symptoms and carbon monoxide poisoning is possible, seek fresh air immediately and remain active. Do not sit, lie down, or fall asleep. Alert others to the possibility of carbon monoxide poisoning. Seek medical attention if the condition of affected persons does not improve within minutes of breathing fresh air.

## Fuel System

### ⚠ WARNING

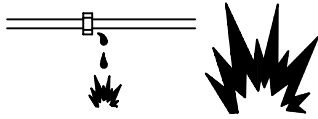

**Explosive fuel vapors. Can cause severe injury or death.**

Use extreme care when handling, storing, and using fuels.

**The fuel system. Explosive fuel vapors can cause severe injury or death.** Vaporized fuels are highly explosive. Use extreme care when handling and storing fuels. Store fuels in a well-ventilated area away from spark-producing equipment and out of the reach of children. Never add fuel to the tank while the engine is running because spilled fuel may ignite on contact with hot parts or from sparks. Do not smoke or permit flames or sparks to occur near sources of spilled fuel or fuel vapors. Keep the fuel lines and connections tight and in good condition. Do not replace flexible fuel lines with rigid lines. Use flexible sections to avoid fuel line breakage caused by vibration. Do not operate the generator set in the presence of fuel leaks, fuel accumulation, or sparks. Repair fuel systems before resuming generator set operation.

**Gas fuel leaks. Explosive fuel vapors can cause severe injury or death.** Fuel leakage can cause an explosion. Check the LP vapor gas or natural gas fuel system for leakage by using a soap and water solution with the fuel system test pressurized to 6-8 ounces per square inch (10-14 inches water column). Do not use a soap solution containing either ammonia or chlorine because both prevent bubble formation. A successful test depends on the ability of the solution to bubble.

## Hazardous Noise

### ⚠ CAUTION



**Hazardous noise. Can cause hearing loss.**

Never operate the generator set without a muffler or with a faulty exhaust system.

**Engine noise. Hazardous noise can cause hearing loss.** Generator sets not equipped with sound enclosures can produce noise levels greater than 105 dBA. Prolonged exposure to noise levels greater than 85 dBA can cause permanent hearing loss. Wear hearing protection when near an operating generator set.

## Hazardous Voltage/ Electrical Shock

### ⚠ DANGER



**Hazardous voltage. Will cause severe injury or death.**

Disconnect all power sources before opening the enclosure.

### ⚠ WARNING

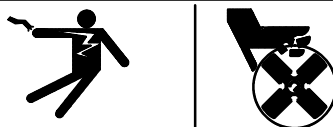

**Hazardous voltage. Moving rotor. Can cause severe injury or death.**

Operate the generator set only when all guards and electrical enclosures are in place.

### ⚠ WARNING



**Hazardous voltage. Backfeed to the utility system can cause property damage, severe injury, or death.**

If the generator set is used for standby power, install an automatic transfer switch to prevent inadvertent interconnection of standby and normal sources of supply.

### ⚠ CAUTION

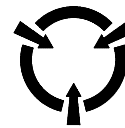

**Welding the generator set. Can cause severe electrical equipment damage.**

Never weld components of the generator set without first disconnecting the battery, controller wiring harness, and engine electronic control module (ECM).

**Grounding electrical equipment. Hazardous voltage can cause severe injury or death.** Electrocutation is possible whenever electricity is present. Open the main circuit breakers of all power sources before servicing the equipment. Configure the installation to electrically ground the generator set, transfer switch, and related equipment and electrical circuits to comply with applicable codes and standards. Never contact electrical leads or appliances when standing in water or on wet ground because these conditions increase the risk of electrocution.

**Welding on the generator set. Can cause severe electrical equipment damage.** Before welding on the generator set perform the following steps: (1) Remove the battery cables, negative (-) lead first. (2) Disconnect all engine electronic control module (ECM) connectors. (3) Disconnect all generator set controller and voltage regulator circuit board connectors. (4) Disconnect the engine battery-charging alternator connections. (5) Attach the weld ground connection close to the weld location.

**Installing the battery charger. Hazardous voltage can cause severe injury or death.** An ungrounded battery charger may cause electrical shock. Connect the battery charger enclosure to the ground of a permanent wiring system. As an alternative, install an equipment grounding conductor with circuit conductors and connect it to the equipment grounding terminal or the lead on the battery charger. Install the battery charger as prescribed in the equipment manual. Install the battery charger in compliance with local codes and ordinances.

**Connecting the battery and the battery charger. Hazardous voltage can cause severe injury or death.** Reconnect the battery correctly, positive to positive and negative to negative, to avoid electrical shock and damage to the battery charger and battery(ies). Have a qualified electrician install the battery(ies).

**Short circuits. Hazardous voltage/current can cause severe injury or death.** Short circuits can cause bodily injury and/or equipment damage. Do not contact electrical connections with tools or jewelry while making adjustments or repairs. Remove all jewelry before servicing the equipment.

**Electrical backfeed to the utility. Hazardous backfeed voltage can cause severe injury or death.** Install a transfer switch in standby power installations to prevent the connection of standby and other sources of power. Electrical backfeed into a utility electrical system can cause severe injury or death to utility personnel working on power lines.

## Heavy Equipment

<b>⚠ WARNING</b>

<p><b>Unbalanced weight. Improper lifting can cause severe injury or death and equipment damage.</b></p> <p>Do not use lifting eyes. Lift the generator set using lifting bars inserted through the lifting holes on the skid.</p>

## Hot Parts



<b>⚠ WARNING</b>

<p><b>Hot engine and exhaust system. Can cause severe injury or death.</b></p> <p>Do not work on the generator set until it cools.</p>

**Servicing the generator. Hot parts can cause severe injury or death.** Avoid touching the generator set field or exciter armature. When shorted, the generator set field and exciter armature become hot enough to cause severe burns.

**Servicing the exhaust system. Hot parts can cause severe injury or death.** Do not touch hot engine parts. The engine and exhaust system components become extremely hot during operation.

**Servicing the engine heater. Hot parts can cause minor personal injury or property damage.** Install the heater before connecting it to power. Operating the heater before installation can cause burns and component damage. Disconnect power to the heater and allow it to cool before servicing the heater or nearby parts.

## Moving Parts

<b>⚠ WARNING</b>	
	
<p><b>Hazardous voltage. Moving rotor. Can cause severe injury or death.</b></p> <p>Operate the generator set only when all guards and electrical enclosures are in place.</p>	

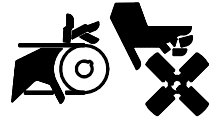
<b>⚠ WARNING</b>

<p><b>Rotating parts. Can cause severe injury or death.</b></p> <p>Operate the generator set only when all guards, screens, and covers are in place.</p>

<b>⚠ WARNING</b>

<p><b>Airborne particles. Can cause severe injury or blindness.</b></p> <p>Wear protective goggles and clothing when using power tools, hand tools, or compressed air.</p>

**Tightening the hardware. Flying projectiles can cause severe injury or death.** Loose hardware can cause the hardware or pulley to release from the generator set engine and can cause personal injury. Retorque all crankshaft and rotor hardware after servicing. Do not loosen the crankshaft hardware or rotor throbolt when making adjustments or servicing the generator set. Rotate the crankshaft manually in a clockwise direction only. Turning the crankshaft bolt or rotor throbolt counterclockwise can loosen the hardware.

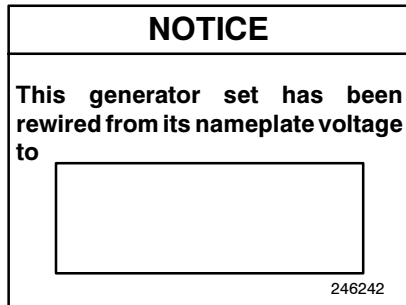

**Servicing the generator set when it is operating. Exposed moving parts can cause severe injury or death.** Keep hands, feet, hair, clothing, and test leads away from the belts and pulleys when the generator set is running. Replace guards, screens, and covers before operating the generator set.

## Notice



## NOTICE

**Voltage reconnection.** Affix a notice to the generator set after reconnecting the set to a voltage different from the voltage on the nameplate. Order voltage reconnection decal 246242 from an authorized service distributor/dealer.

## NOTICE

**Hardware damage.** The engine and generator set may use both American Standard and metric hardware. Use the correct size tools to prevent rounding of the bolt heads and nuts.

## NOTICE

**When replacing hardware, do not substitute with inferior grade hardware.** Screws and nuts are available in different hardness ratings. To indicate hardness, American Standard hardware uses a series of markings, and metric hardware uses a numeric system. Check the markings on the bolt heads and nuts for identification.

## NOTICE

**Canadian installations only.** For standby service connect the output of the generator set to a suitably rated transfer switch in accordance with Canadian Electrical Code, Part 1.

## NOTICE

**Electrostatic discharge damage.** Electrostatic discharge (ESD) damages electronic circuit boards. Prevent electrostatic discharge damage by wearing an approved grounding wrist strap when handling electronic circuit boards or integrated circuits. An approved grounding wrist strap provides a high resistance (about 1 megohm), *not a direct short*, to ground.

# Notes

This manual provides operation and maintenance instructions for model 8.5RES and 12RES generator sets equipped with the Kohler® Advanced Digital Control (ADC 2100).

This generator set is approved for use in stationary applications in locations served by a reliable utility power source. Have the generator set installed by an authorized distributor/dealer or service technician. Refer to TP-6328, Installation Manual, for installation instructions.

Information in this publication represents data available at the time of print. The manufacturer may provide this manual for models not listed on the front cover. Kohler Co. reserves the right to change this publication and the products represented without notice and without any obligation or liability whatsoever.

Read this manual and carefully follow all procedures and safety precautions to ensure proper equipment operation and to avoid bodily injury. Read and follow the Safety Precautions and Instructions section at the beginning of this manual. Keep this manual with the equipment for future reference.

The equipment service requirements are very important to safe and efficient operation. Inspect the parts often and perform required service at the prescribed intervals. Obtain service from an authorized service distributor/dealer to keep equipment in top condition.

## Nameplate

The following illustration shows a typical generator set nameplate. Copy the model, serial, and specification numbers from the nameplate into the spaces provided in the product information section on the inside front cover of this manual. See Section 1.5, Service Views, for the nameplate location.

<b>KOHLER</b> <sup>®</sup>					
KOHLER CO. KOHLER WI. USA					
MODEL:			SERIAL:		
SPEC:					
SERVICE DUTY:					
HZ:    RPM:					
VOLTAGE	AMPS	PHASE	KW	KVA	P.F.
GEN. MODEL:				BATT. V	
INSULATION: NEMA CLASS					
KW VARIES WITH BTU CONTENT OF FUEL					

## EPA and California Emission Certification

An engine or generator set with the following identification labels is certified to meet Small Off-Road Engine emission standards for EPA/CARB. All model 8.5RES and 12RES generator sets with multi-fuel systems are emission-certified.

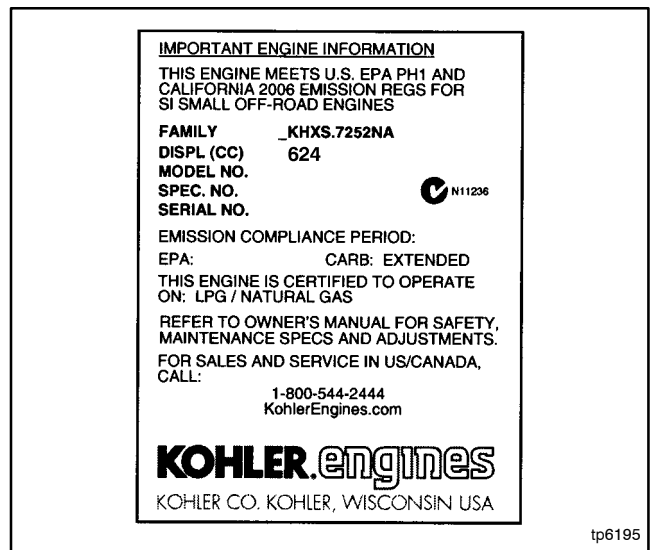

Figure 1 Emissions Label, 8.5RES Engine (CH20)

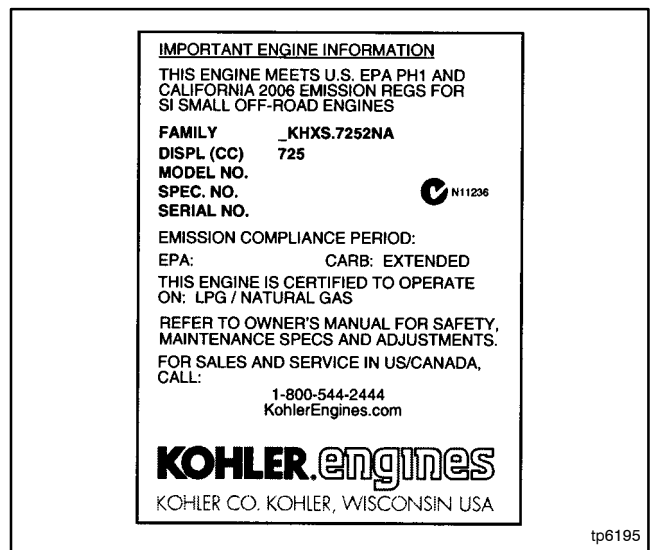
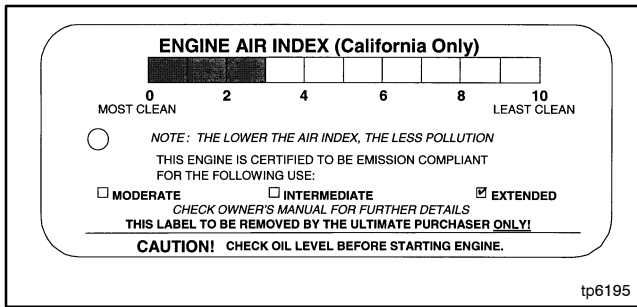

Figure 2 Emissions Label, 12 RES Engine (CH740)



**Figure 3** Air Index Label, 8.5/12RES

This engine/generator is certified to operate using natural gas or propane fuel.

The Emission Compliance Period referred to on the Emission Control or Air Index label indicates the number

of operating hours for which the engine has been shown to meet CARB emission requirements. The following table provides the engine compliance period (in hours) associated with the category descriptor found on the certification label.

Emission Compliance Period (hours)			
CARB	Moderate, 125	Intermediate, 250	Extended, 500

Refer to the certification label for engine displacement.

The exhaust emission control system for the 8.5RES (CH20) and 12RES (CH740) is EM.

## Service Assistance

For professional advice on generator power requirements and conscientious service, please contact your nearest Kohler distributor or dealer.

- Consult the Yellow Pages under the heading Generators—Electric
- Visit the Kohler Power Systems website at [KohlerPowerSystems.com](http://KohlerPowerSystems.com)
- Look at the labels and stickers on your Kohler product or review the appropriate literature or documents included with the product
- Call toll free in the US and Canada 1-800-544-2444
- Outside the US and Canada, call the nearest regional office

### Headquarters Europe, Middle East, Africa (EMEA)

Kohler Power Systems  
 ZI Senia 122  
 12, rue des Hauts Flouviars  
 94517 Thiais Cedex  
 France  
 Phone: (33) 1 41 735500  
 Fax: (33) 1 41 735501

### Asia Pacific

Power Systems Asia Pacific Regional Office  
 Singapore, Republic of Singapore  
 Phone: (65) 264-6422  
 Fax: (65) 264-6455

### China

North China Regional Office, Beijing  
 Phone: (86) 10 6518 7950  
 (86) 10 6518 7951  
 (86) 10 6518 7952  
 Fax: (86) 10 6518 7955

East China Regional Office, Shanghai  
 Phone: (86) 21 6288 0500  
 Fax: (86) 21 6288 0550

### India, Bangladesh, Sri Lanka

India Regional Office  
 Bangalore, India  
 Phone: (91) 80 3366208  
 (91) 80 3366231  
 Fax: (91) 80 3315972

### Japan, Korea

North Asia Regional Office  
 Tokyo, Japan  
 Phone: (813) 3440-4515  
 Fax: (813) 3440-2727

### Latin America

Latin America Regional Office  
 Lakeland, Florida, USA  
 Phone: (863) 619-7568  
 Fax: (863) 701-7131

## 1.1 Specifications

The generator set specification sheets provide specific generator and engine information. Refer to the spec sheet for data not supplied in this manual. Consult the generator set service manual, engine operation manual, and engine service manual for additional specifications. Obtain copies of the latest spec sheets, manuals, diagrams, and drawings from your local distributor/dealer.

## 1.2 Generator

The generator uses Kohler's unique PowerBoost™ voltage regulation system, which provides instant response to load changes.

PowerBoost™ ensures reliable motor starting and consistent voltage levels. PowerBoost™ utilizes a voltage excitation system that employs a winding independent of the main output windings to provide excitation voltage.

## 1.3 Engine

The generator set has a four-cycle, twin cylinder, air-cooled Kohler® engine. The engine operates on clean-burning natural gas or propane (LP) vapor. Engine features include:

- Efficient overhead valve design and full pressure lubrication for maximum power, torque, and reliability under all operating conditions.
- Dependable, maintenance-free electronic ignition.
- Precision-formulated cast iron construction of parts subjected to the most wear and tear.
- Field-convertible multi-fuel systems that allow fuel changeover from natural gas to LP vapor (and vice-versa) while maintaining CARB emission certification.
- Digital spark-advance module (DSAM) optimizes ignition timing for the selected fuel (12RES).

## 1.4 Advanced Digital Control

The generator set is equipped with the Kohler® Advanced Digital Control (ADC 2100). Controller features include the following:

- Compact controller
- Integrally mounted to the generator set
- LED display:
  - Runtime hours
  - Crank cycle status
  - Diagnostics
- LED display communicates faults:
  - High battery voltage
  - High engine temperature
  - Low battery voltage
  - Low oil pressure
  - Overcrank safety
  - Overspeed
  - Overfrequency
  - Overvoltage
  - Underfrequency
  - Undervoltage
- Membrane keypad for configuration and adjustment
  - Password-protected user access to menus
  - Voltage, gain, and speed adjustment
  - System configuration (system voltage, phase, and frequency settings, battery voltage, and generator set model)
- Master control switch: Run/Off-Reset/Auto
- Remote two-wire start/stop capability
- Superior electronics protection from corrosion and vibration
  - Potted electronics
  - Sealed connections
- Digital isochronous governor to maintain steady-state speed at all loads
- Digital voltage regulation:  $\pm 1.5\%$  RMS no-load to full-load
- Automatic start for programmed cranking cycle

## 1.5 Generator Set Components

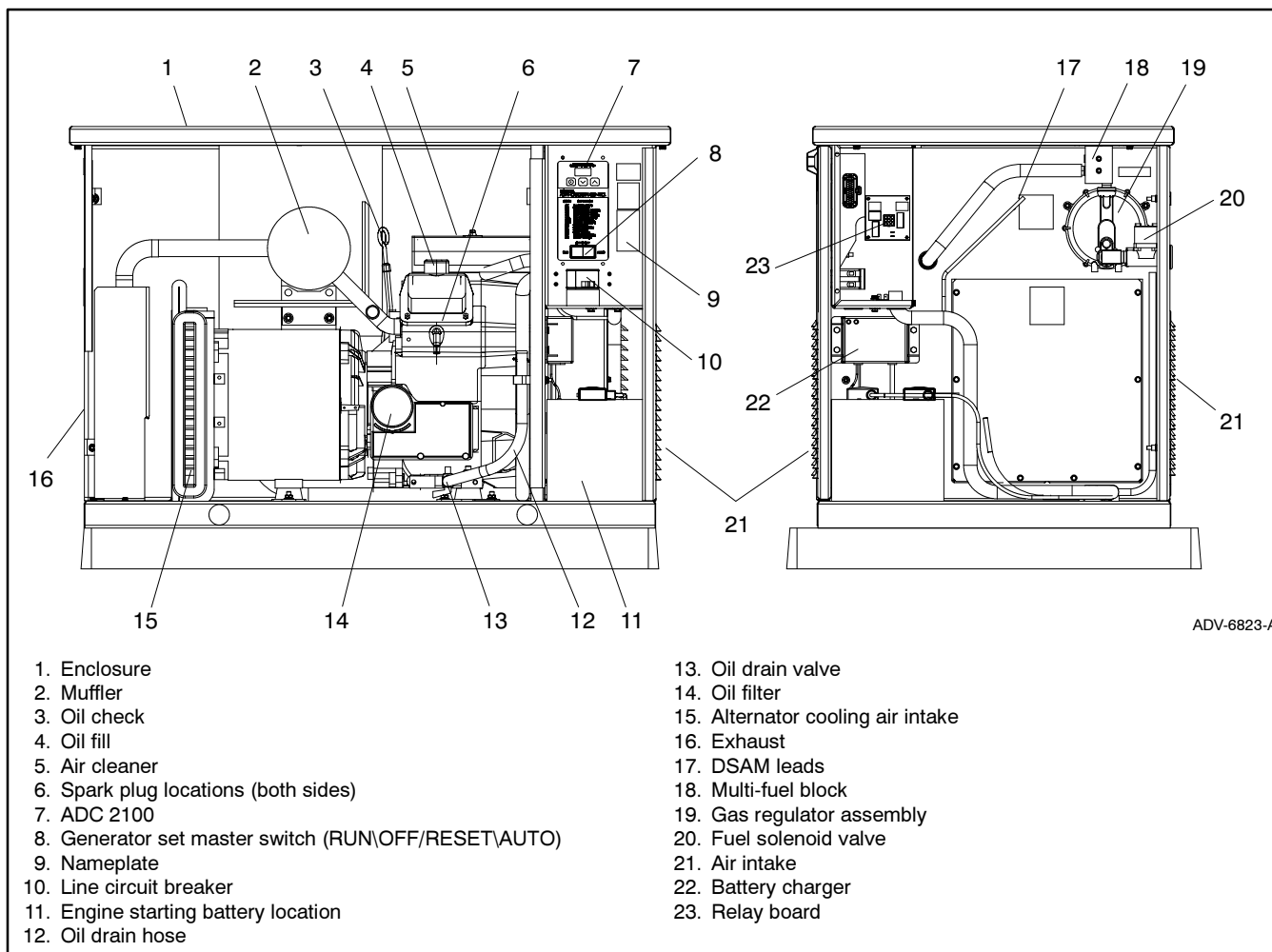

**Figure 1-1** Generator Set Components

## 2.1 Prestart Checklist

To ensure continued satisfactory operation, perform the following checks or inspections before or at each startup, as designated, and at the intervals specified in the service schedule. In addition, some checks require verification after the unit starts.

**Air Cleaner.** Check for a clean and installed air cleaner element to prevent unfiltered air from entering the engine.

**Air Inlets.** Check for clean and unobstructed air inlets.

**Battery.** Check for tight battery connections. Consult the battery manufacturer's instructions regarding battery care and maintenance.

**Exhaust System.** Check for exhaust leaks and blockages. Check the muffler and piping condition and check for tight exhaust system connections.

Inspect the exhaust system components (exhaust manifold, exhaust line, flexible exhaust, clamps, silencer, and outlet pipe) for cracks, leaks, and corrosion.

- Check for corroded or broken metal parts and replace them as needed.
- Check that the exhaust outlet is unobstructed.
- Visually inspect for exhaust leaks (*blowby*). Check for carbon or soot residue on exhaust components. Carbon and soot residue indicates an exhaust leak. Seal leaks as needed.

**Oil Level.** Maintain the oil level at or near, not over, the full mark on the dipstick.

**Operating Area.** Check for obstructions that could block the flow of cooling air. Keep the air intake area clean. Do not leave rags, tools, or debris on or near the generator set.

x:op:001:002

## 2.2 Exercising Generator Set

Operate the generator set without load once each week for 20 minutes. If the generator set does not have a programmed exercise mode or an automatic transfer switch (ATS) with an exercise option, exercise the unit in the presence of an operator.

The operator should perform all of the prestart checks before starting the exercise procedure. Start the generator set according to the starting procedure in the controller section of this manual. While the generator set is operating, listen for a smooth-running engine and visually inspect the generator set for fluid or exhaust leaks. Check the air inlets and outlets and remove any items restricting the air flow.

## 2.3 Generator Set Operation

Figure 2-1 illustrates the user interface on the Advanced Digital Control (ADC 2100) generator set controller.

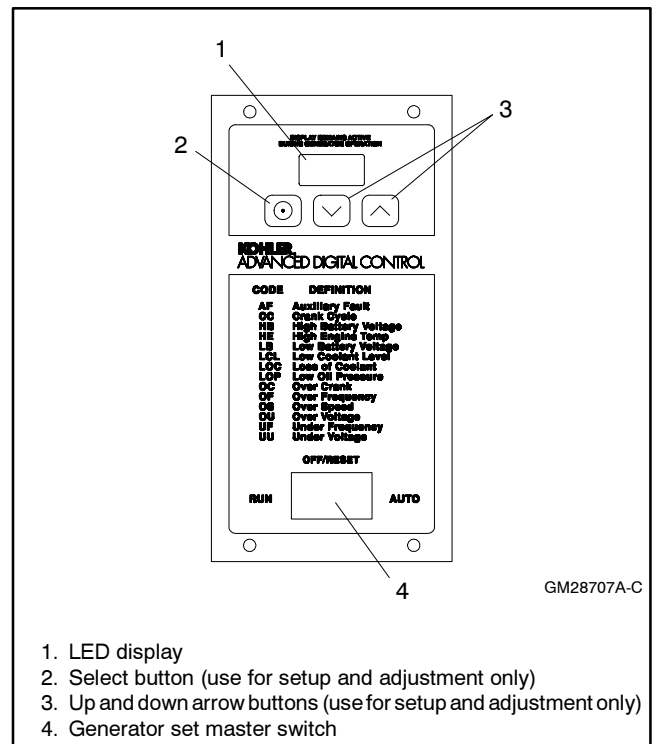

Figure 2-1 ADC 2100 User Interface

### 2.3.1 Controls and Indicators

Figure 2-2 describes the controls and indicators located on the ADC 2100. The LED display indicates generator set status as shown in Figure 2-2.

With the factory-installed continuous power mode jumper in place, the LED display is activated when the generator set master switch is moved to the RUN or AUTO position and remains active until the master switch is moved to the OFF/RESET position or power to the controller is removed. If the continuous power mode jumper has been disconnected, the LED display is activated by a start or RUN command and turns off 48 hours after generator set shutdown. See Section 2.5.

The buttons on the controller keypad are used only for system configuration and adjustment. The system configuration is factory-set and should not require changes under normal operating conditions. Contact an authorized distributor/dealer or service technician if adjustments are required.

### 2.3.2 Starting Generator Set

The following procedures describe the actions required to start the generator set.

The controller attempts to start the generator set three times (three crank cycles, 15 seconds crank and 15 seconds off). If the generator set does not start in three attempts, the system shuts down on an overcrank fault.

#### Local Starting

Move the generator set master switch to the RUN position to immediately start the generator set.

#### Auto (Automatic) Starting

Move the generator set master switch to the AUTO position to allow startup by an automatic transfer switch (ATS) or remote start/stop switch, if equipped.

### 2.3.3 Stopping Generator Set

The following procedures describe the actions required to stop the generator set.

#### Local Stopping

1. Run the generator set at no load for at least 2 minutes to ensure adequate engine cooldown.
2. Move the generator set master switch to the OFF/RESET position. The engine stops.

#### Automatic Stopping

With the generator set master switch in the AUTO position and an (ATS) or other automatic device connected to controller leads 3 and 4:

1. The ATS or other device disconnects the load from the generator set.
2. If the ATS is equipped with an engine cooldown time delay, the generator set continues to run for a preset engine cooldown time.

**Note:** There is no engine cooldown time delay on the ADC controller.

3. The ATS or other device opens the connection between controller leads 3 and 4. The generator set shuts down.

Control or Indicator	Item	Description
LED display	Runtime hours	Displays total generator set runtime hours while the generator set is running and when no other codes are displayed.
	Crank indication	Displays CC_1, CC_2, or CC_3 to indicate the first, second, or third attempt to start the engine. The last digit flashes during the crank cycle rest periods.
	Fault codes	Flashes a 2- or 3-letter fault code to indicate various fault conditions. See Section 2.4.
	Software version number	See TP-6196, Generator Set Service Manual. Contact an authorized distributor/dealer.
Keypad	Select and arrow buttons	The keypad is used for controller setup and adjustment only. Have setup and adjustments performed only by an authorized distributor/dealer. The setup and adjustment functions are password-protected.
Generator set master switch	Three-position switch	Switch functions as the generator set operation and controller reset switch.

**Figure 2-2** ADC 2100 Controls and Indicators



## 2.4 Fault Shutdowns

The generator set shuts down automatically under the fault conditions listed in Figure 2-3 and the controller displays a fault code. The generator set cannot be restarted until the fault condition is corrected and the controller is reset. See Section 2.4.1 to reset the controller after a fault shutdown. The controller resets automatically after a battery voltage fault condition is corrected.

The shutdown switches on the generator set automatically reset when the problem is corrected. The high engine temperature switch automatically resets when the generator set cools. However, the fault does not clear until the controller is reset.

The controller displays a fault code but the generator set does not shut down under the conditions shown in Figure 2-4.

Code	Fault	Description	Check
AF	Auxiliary fault input shutdown	Not used.	—
HE	High engine temperature shutdown	Shutdown occurs if the engine coolant temperature exceeds the maximum temperature for more than 5 seconds. This protective becomes active after the engine reaches the crank disconnect speed.	Check for blocked air inlets and exhaust outlets.
LCL	Low coolant level	Not used on air-cooled models.	—
LOC	Loss of coolant	Not used on air-cooled models.	—
LOP	Low oil pressure shutdown	Shutdown occurs if a low oil pressure condition exists for more than 5 seconds. This protective becomes active 30 seconds after the engine has reached crank disconnect speed (30 second inhibit). <b>Note:</b> The low oil pressure shutdown does not protect against low oil level. Check the oil level at the engine.	Check for leaks in the lubrication system. Check the oil level and add oil if the level is low.
OC	Overcrank shutdown	Shutdown occurs after 3 unsuccessful starting attempts. The crank cycle is set for three starting attempts of 15 seconds cranking and 15 seconds rest.  The generator set also shuts down if no engine rotation is sensed during cranking. Shuts down 1 second after the fault is detected.	Check the fuel supply, spark plug, and battery. Check for loose connections. Contact an authorized distributor/dealer for service if problem continues.
OF	Overfrequency shutdown	Shutdown occurs when the governed frequency exceeds 110% of the system's frequency setpoint for more than 5 seconds. This protective becomes active 10 seconds after engine start (10 second inhibit).	Contact an authorized distributor/dealer for service if problem continues.
OS	Overspeed shutdown	Shutdown occurs if the engine speed exceeds 115% of the normal running speed for more than 0.3 seconds.	Contact an authorized distributor/dealer for service if problem continues.
OU	Overvoltage shutdown	Shutdown occurs if the voltage exceeds 120% of the system nominal voltage for more than 2 seconds.	Contact an authorized distributor/dealer for service if problem continues.
UF	Underfrequency shutdown	Shutdown occurs when the governed frequency falls below 90% of the nominal system frequency for more than 5 seconds. This protective becomes active 10 seconds after engine start. (10 second inhibit).	Reduce the load and restart the generator set. Contact an authorized distributor/dealer for service if problem continues.
UU	Undervoltage shutdown	Shutdown occurs if the voltage falls below 80% of the nominal system voltage for more than 10 seconds.	Reduce the load and restart the generator set. Contact an authorized distributor/dealer for service if problem continues.

Figure 2-3 ADC 2100 Fault Shutdown Codes

Code	Fault	Description	Check
HB	High battery voltage warning	Fault code is displayed if the engine starting battery voltage rises above 16 VDC for a 12 VDC system or above 30 VDC for a 24 VDC system for more than 10 seconds when the engine is not running. This fault condition does not inhibit engine starting.  The fault condition clears when the battery voltage returns to a voltage within the limits for more than 10 seconds.	Check the battery rating and condition.  Check the battery charger operation.
LB	Low battery voltage warning	Fault code is displayed if the engine starting battery voltage falls below 8 VDC for a 12 VDC system or below 16 VDC for a 24 VDC system for more than 10 seconds when the engine is not running. This fault condition does not inhibit engine starting.  The fault condition clears when the battery voltage returns to a voltage within the limits for more than 10 seconds.	Check the battery rating and condition. Check the battery charger operation. Charge or replace the battery.

**Figure 2-4** ADC 2100 Fault Warning Codes

### 2.4.1 Resetting Controller after a Fault Shutdown

Always identify and correct the cause of a fault shutdown before resetting the controller. Use the following procedure to reset the generator set controller after a fault shutdown.

1. Move the generator set master switch to OFF/RESET.
2. Disconnect the generator set from the load using the line circuit breaker or ATS. See the safety precautions at the beginning of this section before proceeding.
3. Identify and correct the cause of the fault shutdown. See the safety precautions at the beginning of this section before proceeding. Refer to Section 4, Troubleshooting.
4. Start the generator set by moving the generator set master switch to RUN. Test operate the generator set to verify that the cause of the shutdown has been corrected.
5. Move the generator set master switch to OFF/RESET.
6. Reconnect the generator set to the load using the line circuit breaker or ATS.

7. Move the generator set master switch to the AUTO position for startup by remote transfer switch or remote start/stop switch.

**Note:** The controller's LED display remains off until an engine start command is received.

Opening and closing a remote start/stop contact also resets the controller.

## 2.5 Continuous Power Mode

The ADC 2100 is powered by the generator set engine starting battery. A jumper on the back of the controller maintains power to the controller at all times. Controllers are shipped with the jumper connected.

**Note:** The 8.5 and 12 RES generator sets are equipped with factory-installed battery chargers to prevent battery discharge.

Disconnecting the jumper allows the controller to power down automatically 48 hours after the generator set shuts down if the generator set master switch is in the AUTO position. A remote start signal (from a transfer switch or a remote start/stop switch connected to controller leads 3 and 4) or moving the generator set master switch to the RUN position turns the controller back on.

Contact an authorized distributor/dealer to disconnect the jumper, if necessary.

## 2.6 Battery Charger

The generator set is equipped with a 6-amp float/equalize battery charger to maintain the engine starting battery. The charger's power cord must be connected to a 120 VAC power source. Figure 2-5 illustrates the battery charger.

The battery charger uses an AGS 10 inline fuse. The fuse is located in the battery lead. See Figure 2-5.

### 2.6.1 Battery Charger Operation

Figure 2-6 illustrates the three-stage charging method. Red and green LEDs indicate charger operation. The chart in Figure 2-7 describes the LED indicator operation during each stage of the charging process.

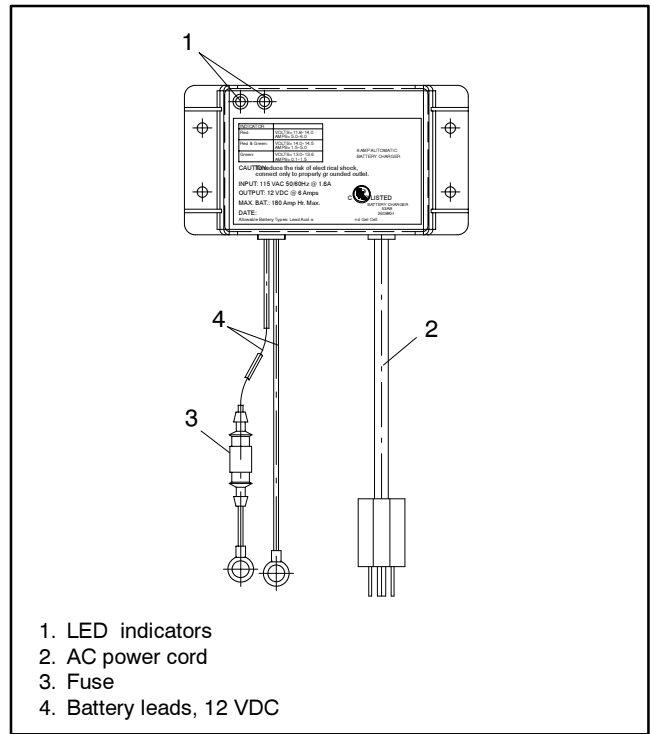

**Figure 2-5** 6-Amp Float/Equalize Battery Charger

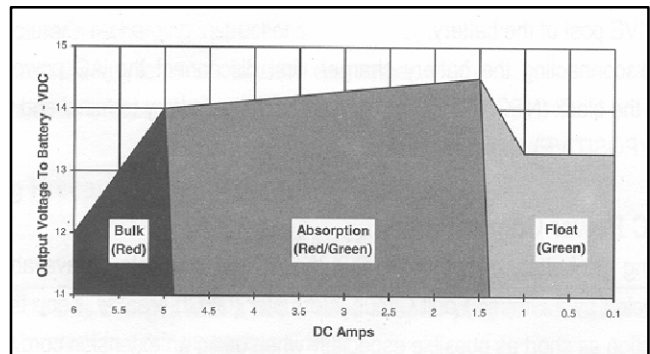

**Figure 2-6** Charging Method

Display	Operating Condition
Red ON Green OFF	When the red LED is on, it indicates the battery is discharged and the battery charger is recharging at the BULK rate (stage 1). This charging rate is 6 amps. While the red LED is on, the voltage measured (with the battery charger on) will be 11.8-14 volts. If the red LED stays on for more than 24 hours, refer to Section 4.5 in this manual.
Red ON Green ON	When both the green and the red LEDs are on, the battery charger is charging at an ABSORPTION rate of between 1.5 and 5 amps (stage 2). This mode of charging gradually tops off your battery, and reduces harmful sulfating. While both LEDs are on, the voltage measured (with the battery charger on) should be approximately 14.0-14.5 VDC. If both LEDs stay on longer than 24 hours, refer to Section 4.5 in this manual.
Red OFF Green ON	When the green LED is on, the battery charger is charging at a FLOAT or MAINTENANCE rate of less than 1.5 amps (stage 3). Your battery is now 90% charged and ready for use. This float charging current will gradually decrease to as low as 0.1 amps as the battery reaches 100% charge. It will now be kept at full charge without overcharging. If the green LED stays on when your battery is known to be low, refer to Section 4.5 in this manual.

**Figure 2-7** Battery Charger LED Indicator Functions

# Notes

## Section 3 Scheduled Maintenance

### WARNING

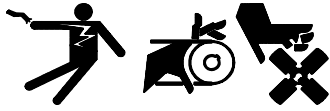

**Accidental starting.**  
**Can cause severe injury or death.**

Disconnect the battery cables before working on the generator set. Remove the negative (-) lead first when disconnecting the battery. Reconnect the negative (-) lead last when reconnecting the battery.

**Disabling the generator set. Accidental starting can cause severe injury or death.** Before working on the generator set or connected equipment, disable the generator set as follows: (1) Move the generator set master switch to the OFF position. (2) Disconnect the power to the battery charger. (3) Remove the battery cables, negative (-) lead first. Reconnect the negative (-) lead last when reconnecting the battery. Follow these precautions to prevent starting of the generator set by an automatic transfer switch, remote start/stop switch, or engine start command from a remote computer.

### WARNING



**Hot engine and exhaust system.**  
**Can cause severe injury or death.**

Do not work on the generator set until it cools.

**Servicing the exhaust system. Hot parts can cause severe injury or death.** Do not touch hot engine parts. The engine and exhaust system components become extremely hot during operation.

### WARNING



**Hazardous voltage. Moving rotor.**  
**Can cause severe injury or death.**

Operate the generator set only when all guards and electrical enclosures are in place.

**Servicing the generator set when it is operating. Exposed moving parts can cause severe injury or death.** Keep hands, feet, hair, clothing, and test leads away from the belts and pulleys when the generator set is running. Replace guards, screens, and covers before operating the generator set.

## 3.1 Routine Maintenance

Refer to the following service schedule and the runtime hours displayed on the ADC 2100 display to schedule routine maintenance. Have an authorized distributor/dealer service the generator set at the designated intervals in the service schedule for the life of the generator set. Service units subject to extreme weather, long operating hours, or dusty or dirty conditions more frequently.

Contact an authorized distributor/dealer for parts.

### 3.2 Service Schedule

System Component or Procedure	See Section	Procedure					Frequency
		Visually Inspect	Check	Change	Clean	Test	
<b>Fuel</b>							
Flexible lines and connections		X		R			Quarterly
Main tank supply level			X				Weekly
Fuel piping		X					Yearly
<b>Lubrication</b> 3.3							
Oil level		X	X				8 hours or before use
Crankcase breather hose		X					Yearly or 500 hours
Change oil				X			Yearly or 100 hours
Replace filter				X			Yearly or 200 hours
<b>Cooling</b> 3.6							
Air ducts, louvers			X		X		Yearly
<b>Exhaust Line</b> 3.7							
Leakage		X	X				Weekly
Insulation, fire hazards		X					Yearly
Obstructions or combustible materials near exhaust outlet		X					Weekly
<b>DC Electrical System</b> 3.8							
Battery charger operation, charge rate (if equipped)		X					Monthly
Remove corrosion, clean and dry battery and rack		X			X		Yearly
Clean and tighten battery terminals and inspect boots		X	X				Yearly
Battery electrolyte level and specific gravity *			X				Yearly
<b>AC Electrical System</b>							
Tighten control and power wiring connections			X				Yearly
Remote control system, if equipped						X	Monthly
Visible wear or damage		X					Quarterly
Wire abrasions where subject to motion		X	X				Six Months
Wire-cable insulation condition		X					3 Years or 500 hours
<b>Engine and Mounting</b>							
Visible wear or damage		X					Weekly
Air cleaner and precleaner service	3.5			R			Yearly or 100 hours
Spark plugs	3.4			X			Yearly or 300 hours
Replace stepper motor coupling and bushing				D			500 hours
<b>Generator</b>							
Visible wear or damage	2.1	X					Quarterly
Exercise generator set	2.2					X	Weekly
Brushes and collector ring			D		D		Yearly
Measure and record resistance readings of windings with insulation tester (Megger®, with SCR assembly or rectifier and load leads disconnected) *						D	3 Years
<b>General Condition of Equipment</b>							
Evidence of vibration, leakage, excessive noise, temperature, or deterioration		X	X		X		Weekly
Interior of sound enclosure		X			X		Quarterly
* Not necessary for maintenance-free batteries.		D Authorized distributor/dealer only X Action R Replace as necessary					

Megger® is a registered trademark of Biddle Instruments.

### 3.3 Lubrication System

See Section 3.2, Service Schedule, for oil change and oil filter replacement intervals. See Section 1.5, Service Views, for the oil drain, oil check, oil fill, and oil filter locations.

For extended operation, check the oil level every 8 hours. Maintain the oil level at or near, not over, the full mark on the dipstick.

#### 3.3.1 Low Oil Pressure Shutdown

The low oil pressure shutdown feature protects the engine against internal damage if the oil pressure drops below  $24.1 \text{ kPa} \pm 13.8 \text{ kPa}$  ( $3.5 \text{ psi} \pm 1.5 \text{ psi}$ ) because of oil pump failure or other malfunction. The shutdown feature does not protect against damage caused by operating with the oil level below the safe range; it is not a low oil level shutdown. Check the oil level regularly, and add oil as needed.

#### 3.3.2 Oil Check

The generator set is shipped with oil. Before operating a new generator set, check the engine oil in the crankcase. See Section 1.5, Generator Set Components. Verify that the oil level is at the F mark on the dipstick. Add oil that has a viscosity appropriate for the climate. See Section 3.3.3, Engine Oil Recommendation.

Do not check the oil level when the generator set is running. Shut down the generator set and wait several minutes before checking the oil level.

#### 3.3.3 Engine Oil Recommendation

Use API (American Petroleum Institute) Service Class SG, SH, or SJ synthetic oil. Synthetic oil oxidizes and thickens less than other oils and leaves the engine intake valves and pistons cleaner. Select the viscosity based on the air temperature at the time of operation. See Figure 3-1.

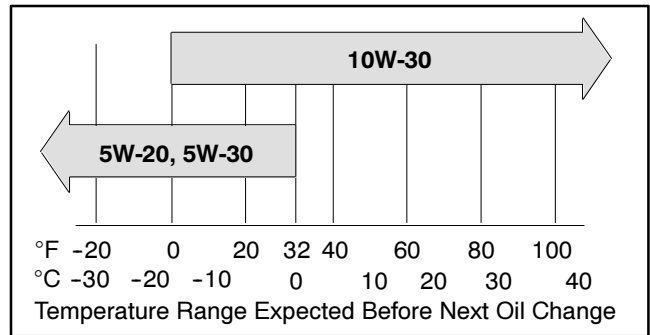

Figure 3-1 Engine Oil Selection

#### 3.3.4 Oil Change Procedure

Drain the oil while it is still warm.

1. **Drain the oil.**

- a. Place the generator set master switch in the OFF position.
- b. Disconnect the power to the battery charger.
- c. Disconnect the generator set engine starting battery, negative (-) lead first.
- d. Remove the housing side panel.
- e. Remove the oil drain hose from its retaining clip. Remove the cap from the oil drain hose and lower the hose into an oil collection container.
- f. Open the oil drain valve on the engine.
- g. Allow time for the engine oil to drain completely.
- h. Close the oil drain valve.
- i. Replace the cap on the oil drain hose. Replace the oil drain hose in its retaining clip.

2. **Replace the oil filter.**

- a. Remove the oil filter by rotating it counterclockwise with an oil filter wrench.

- b. Clean the gasket sealing surface of the oil filter adapter.
- c. Apply a light coat of clean oil to the rubber seal of the new oil filter.
- d. Install the new oil filter following the instructions provided with the filter.

**Note:** Dispose of all waste materials (engine oil, fuel, filter, etc.) in an environmentally safe manner.

### 3. Fill with oil.

- a. Remove the oil fill cap and fill the engine to the F mark on the dipstick. The engine oil capacity is 1.9 L (2.0 qt.). See Section 3.3.3, Engine Oil Recommendation, for oil selection.
- b. Reinstall the dipstick and the oil fill cap.
- c. Check that the generator set master switch is in the OFF position.
- d. Reconnect the generator set engine starting battery, negative (-) lead last.
- e. Reconnect the power to the battery charger.
- f. Start and run the generator set for a minute to allow the oil pressure to reach the operating range.
- g. Stop the generator set, wait 1 minute, and then recheck the oil level. Add oil to bring the level up to the F mark on the dipstick.

### 4. Check for leaks.

- a. Check for oil leaks.
- b. Fix leaks and recheck the oil level.
- c. Reinstall the housing side panel.

## 3.4 Spark Plugs

Reset the spark plug gap or replace the plugs with new plugs as necessary.

1. Clean the area around the base of the spark plug to keep dirt and debris out of the engine.
2. Remove the spark plug and check its condition. Replace the spark plug if it is worn or if its reuse is questionable.
3. Check the spark plug gap using a wire feeler gauge. Adjust the gap to 0.76 mm (0.030 in.) by

carefully bending the ground electrode. See Figure 3-2 and Figure 3-3.

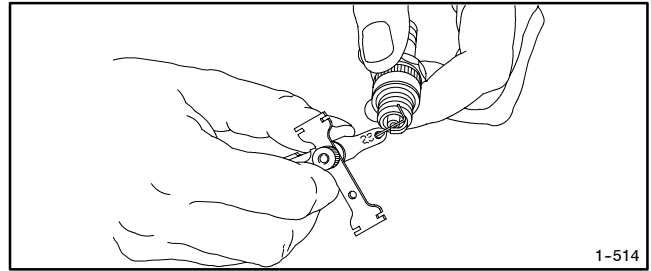

**Figure 3-2** Checking the Spark Plug Gap

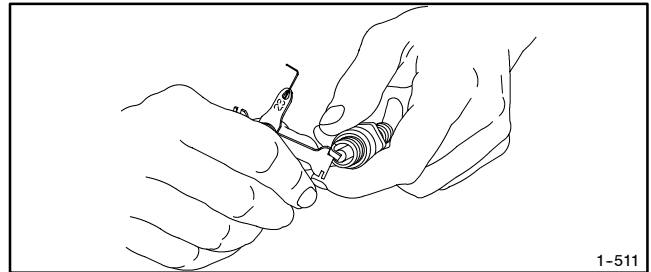

**Figure 3-3** Adjusting the Spark Plug Gap

## 3.5 Air Cleaner Element and Precleaner

The engine has a replaceable high-density paper air cleaner element with an oiled foam precleaner. See Figure 3-4.

Check for a buildup of dirt and debris around the air cleaner system. Keep this area clean.

**Note:** Operating the engine with loose or damaged air cleaner components could allow unfiltered air into the engine causing premature wear and failure.

### 3.5.1 Precleaner Service

Use the following procedure to wash and reoil the precleaner as indicated in the service schedule. Wash and reoil the precleaner more often under extremely dusty or dirty conditions.

1. Place the generator set master switch in the OFF/RESET position.
2. Disconnect the power to the battery charger.
3. Disconnect the battery, negative (-) lead first.
4. Loosen the cover retaining knob and remove the cover. Remove the precleaner from the paper element. Wash the precleaner in warm water with detergent. Rinse the precleaner thoroughly until all



traces of detergent are eliminated. Squeeze out excess water (do not wring). Allow the precleaner to air dry.

5. Saturate the precleaner with new engine oil. Squeeze out all of the excess oil.
6. Reinstall the precleaner over the paper element.
7. Reinstall the air cleaner cover. Secure the cover with the cover retaining knob.
8. Reconnect the power to the battery charger.
9. Reconnect the generator set engine starting battery, negative (-) lead last.

### 3.5.2 Paper Element Service

Use the following procedure to replace the paper element at the intervals specified in the service schedule. Replace the paper element more often under extremely dusty or dirty conditions.

1. Place the generator set master switch in the OFF/RESET position.
  2. Disconnect the power to the battery charger.
  3. Disconnect the generator set engine starting battery, negative (-) lead first.
  4. Loosen the cover retaining knob and remove the cover.
  5. Remove the element cover nut, element cover, and the paper element with precleaner.
  6. Remove the precleaner from the paper element.
- Note:** Do not wash the paper element or clean it with pressurized air, as this will damage the element.
7. Replace the element if it is dirty, bent, or damaged.
  8. Check the air cleaner base. Make sure it is secure and not bent or damaged. Also check the element cover for damage and fit. Replace all damaged air cleaner components. Remove any loose dirt or debris from the air cleaner base. Wipe the base carefully so that no dirt drops into the intake throat. Check the condition of the rubber seal on the air cleaner stud and replace the seal if necessary.
  9. Reinstall the paper element, precleaner, element cover, element cover nut, and the air cleaner cover. Secure the cover with the cover retaining knob.

10. Reconnect the power to the battery charger.

11. Reconnect the generator set engine starting battery, negative (-) lead last.

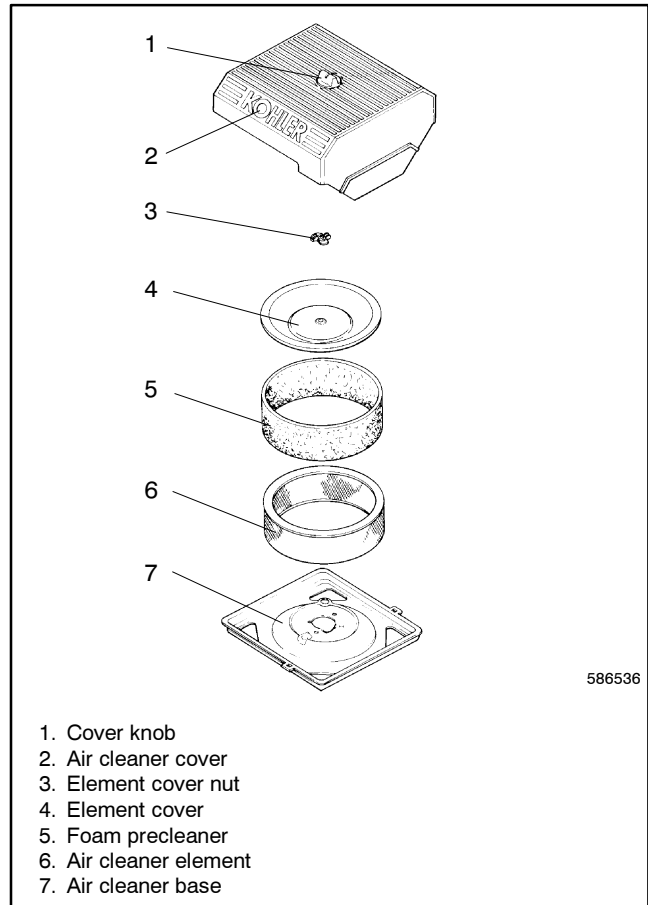
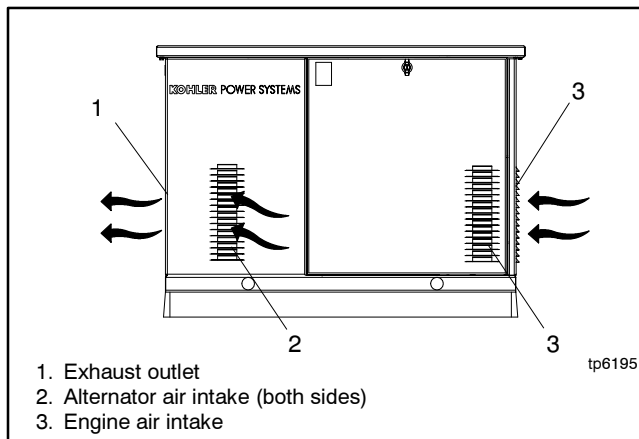

**Figure 3-4** Air Cleaner Components

## 3.6 Cooling System

The engine fan draws cooling air through the openings in the sides and end near the battery. The alternator fan draws cooling air through openings on the side walls of the enclosure. The cooling air mixes with the engine exhaust and is discharged at the exhaust outlet. See Figure 3-5. To prevent generator set damage caused by overheating, keep the housing cooling inlets and outlets clean and unobstructed at all times.

**Note:** Do not block the generator set cooling air inlets or mount other equipment above them. Overheating and severe generator damage may occur.



**Figure 3-5** Cooling Air Intake and Exhaust

## 3.7 Exhaust System

Remove all combustible materials from the exhaust location. Combustible materials include building materials as well as natural surroundings. Keep dry field grass, foliage, and combustible landscaping material a minimum of 1.5 m (5 ft.) from the exhaust outlet.

Periodically inspect the exhaust system components (exhaust manifold, exhaust line, flexible exhaust, clamps, silencer, and outlet pipe) for cracks, leaks, and corrosion.

- Check for corroded or broken metal parts and replace them as needed.
- Check for loose, corroded, or missing clamps and hangers. Tighten or replace clamps and/or hangers as needed.
- Check for and remove loose insulation in the exhaust duct.
- Check that the exhaust outlet is clear.

## 3.8 Battery

### **⚠ WARNING**



**Sulfuric acid in batteries.  
Can cause severe injury or death.**

Wear protective goggles and clothing. Battery acid may cause blindness and burn skin.

**Battery electrolyte is a diluted sulfuric acid. Battery acid can cause severe injury or death.** Battery acid can cause blindness and burn skin. Always wear splashproof safety goggles, rubber gloves, and boots when servicing the battery. Do not open a sealed battery or mutilate the battery case. If battery acid splashes in the eyes or on the skin, immediately flush the affected area for 15 minutes with large quantities of clean water. Seek immediate medical aid in the case of eye contact. Never add acid to a battery after placing the battery in service, as this may result in hazardous spattering of battery acid.

**Battery acid cleanup. Battery acid can cause severe injury or death.** Battery acid is electrically conductive and corrosive. Add 500 g (1 lb.) of bicarbonate of soda (baking soda) to a container with 4 L (1 gal.) of water and mix the neutralizing solution. Pour the neutralizing solution on the spilled battery acid and continue to add the neutralizing solution to the spilled battery acid until all evidence of a chemical reaction (foaming) has ceased. Flush the resulting liquid with water and dry the area.

**Battery gases. Explosion can cause severe injury or death.** Battery gases can cause an explosion. Do not smoke or permit flames or sparks to occur near a battery at any time, particularly when it is charging. Do not dispose of a battery in a fire. To prevent burns and sparks that could cause an explosion, avoid touching the battery terminals with tools or other metal objects. Remove all jewelry before servicing the equipment. Discharge static electricity from your body before touching batteries by first touching a grounded metal surface away from the battery. To avoid sparks, do not disturb the battery charger connections while the battery is charging. Always turn the battery charger off before disconnecting the battery connections. Ventilate the compartments containing batteries to prevent accumulation of explosive gases.

**Battery short circuits. Explosion can cause severe injury or death.** Short circuits can cause bodily injury and/or equipment damage. Disconnect the battery before generator set installation or maintenance. Remove all jewelry before servicing the equipment. Use tools with insulated handles. Remove the negative (-) lead first when disconnecting the battery. Reconnect the negative (-) lead last when reconnecting the battery. Never connect the negative (-) battery cable to the positive (+) connection terminal of the starter solenoid. Do not test the battery condition by shorting the terminals together.

Refer to this section for general battery information and maintenance. Also consult the battery manufacturer's instructions for battery maintenance.

All generator set models use a negative ground with a 12-volt engine electrical system. Consult the generator set nameplate for the engine electrical system voltage. Consult the generator spec sheet for battery capacity recommendations for replacement purposes. Wiring diagrams provide battery connection information. See Figure 3-6 for typical battery connections.

Clean the battery and cables and tighten battery terminals using the service schedule recommendations. To prevent corrosion, maintain tight, dry electrical connections at the battery terminals. To remove corrosion from battery terminals, disconnect the cables from the battery and scrub the terminals with a wire brush. Clean the battery and cables with a solution of baking soda and water. After cleaning, flush the battery and cables with clean water and wipe them with a dry, lint-free cloth.

After reconnecting the battery cables, coat the battery terminals with petroleum jelly, silicone grease, or other nonconductive grease.

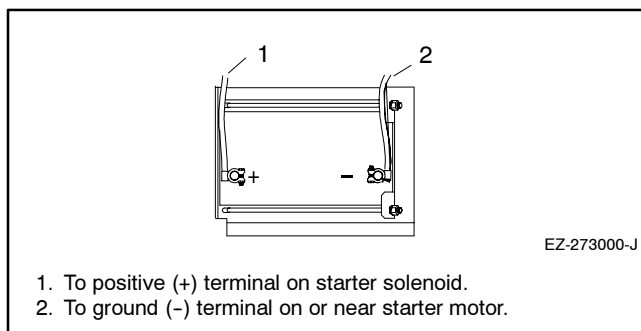
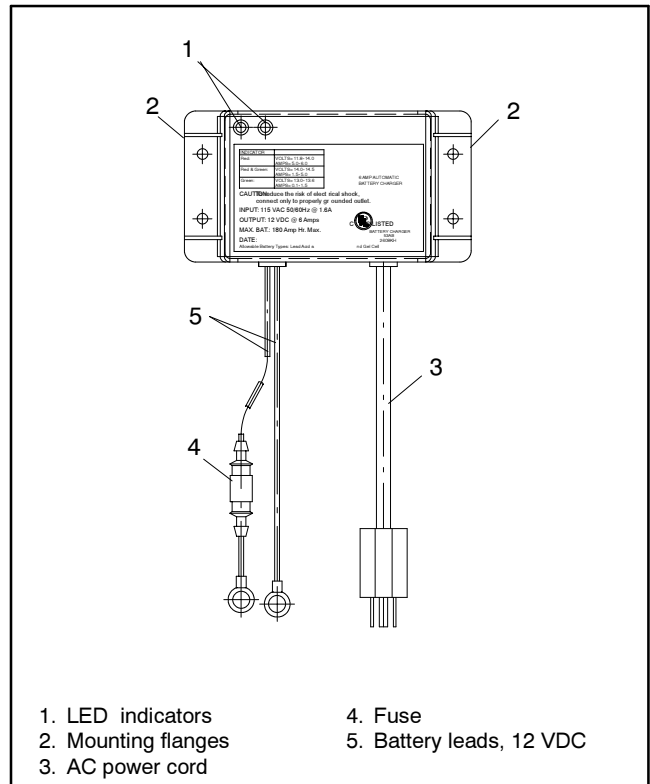

**Figure 3-6** 12-Volt Engine Electrical System Single Starter Motor, Typical Battery Connection

### 3.9 Battery Charger

The generator set is equipped with a 6-amp float/equalize battery charger to maintain the engine starting battery. The charger's DC leads are factory-wired. Figure 3-7 illustrates the battery charger.

Periodically tighten all connections. No other maintenance on the battery charger is required.



**Figure 3-7** 6-Amp Float/Equalize Battery Charger

## 3.10 Circuit Protection

If the generator set circuit breaker trips or the fuses blow repeatedly, see Section 4, Troubleshooting, for possible causes.

### 3.10.1 Line Circuit Breaker

A line circuit breaker interrupts the generator output in the event of a fault in the wiring between the generator and the load. The line circuit breaker location is shown in Figure 1-1. See Figure 3-8 for the circuit breaker ratings. If the circuit breaker trips, reduce the load and switch the breaker back to the ON position. With the breaker in the OFF position the generator set runs but the generator output is disconnected from the load.

Model	Circuit Breaker Rating, Amps
8.5RES	40
12RES	50

**Figure 3-8** Line Circuit Breakers

### 3.10.2 Fuses

The engine harness contains two 10-amp and one 20-amp inline fuses. See Figure 3-9. Another 10-amp fuse protects the battery charger.

Always identify and correct the cause of a blown fuse before restarting the generator set. Refer to Section 4, Troubleshooting, for conditions that may indicate a blown fuse. Replace blown fuses with identical replacement parts.

Fuse	Label	Part Number	Location
Auxiliary winding	F1	292937	Lead 55
Relay interface board	F2	223316	Lead PF2
Controller	F3	223316	Lead PF1
Battery charger	—	AGS 10	Battery charger DC lead. See Section 2.6.

**Figure 3-9** Fuses

## 3.11 Storage Procedure

Perform the following storage procedure before removing the generator set from service for three months or longer. Follow the engine manufacturer's recommendations for storage, if available.

**Note:** Run the generator set monthly whenever possible.

### 3.11.1 Lubricating System

1. Operate the generator set until it reaches operating temperature, or about 15 minutes.
2. Stop the generator set.
3. While the engine is still warm, drain the engine lubrication oil from the engine crankcase.
4. Refill the engine crankcase with oil. See Section 3.3.3 for oil recommendations.
5. Run the generator set for a few minutes to distribute the clean oil.
6. Stop the generator set.

### 3.11.2 Fuel System

1. Start the generator set.
2. With the generator set running, shut off the gas supply.
3. Run the generator set until the engine stops.
4. Place the generator set master switch in the OFF/RESET position.

### 3.11.3 Cylinder Lubrication

1. Remove the spark plugs.
2. Pour one tablespoon of engine oil into each spark plug hole. Install the spark plugs and *ground* the spark plug leads. *Do not connect the leads to the plugs.*
3. Toggle the generator set master switch to crank the engine two or three revolutions to lubricate the cylinders.

### 3.11.4 Exterior Preparation

1. Clean the exterior surface of the generator set.
2. Seal all openings in the engine with nonabsorbent adhesive tape.
3. Mask all areas to be used for electrical contact.

4. Spread a light film of oil over unpainted metallic surfaces to prevent rust and corrosion.

### 3.11.5 Battery

Perform battery storage last.

1. Place the generator set master switch in the OFF/RESET position.
2. Disconnect the battery, negative (-) lead first.
3. Clean the battery. Refer to Section NO TAG for the cleaning procedure.
4. Place the battery in a warm, dry location.
5. Connect the battery to a float/equalize battery charger, or charge the battery monthly using a trickle charger. Follow the battery charger manufacturer's recommendations.

# Notes

## Section 4 Troubleshooting

### 4.1 Introduction

Use the following charts to diagnose and correct common problems. First check for simple causes such as a dead engine starting battery, loose connections, or an open circuit breaker. The charts include a list of common problems, possible causes of the problem, and recommended corrective actions.

If the procedures in this manual do not explain how to correct the problem, contact an authorized distributor/

dealer. Maintain a record of repairs and adjustments performed on the equipment. Use the record to help describe the problem and repairs or adjustments made to the equipment.

### 4.2 Generator Set Troubleshooting

Figure 4-1 contains generator set troubleshooting, diagnostic, and repair information. Check for loose connections before replacing parts.

Problem	Possible Cause	Corrective Action
The generator set does not crank.	Battery weak or dead Battery charger fuse blown Battery connections reversed or poor Controller fuse (F3) blown Relay interface board fuse (F2) blown Generator set master switch in the OFF position	Check power to the battery charger. Recharge or replace the battery. Replace the fuse. Contact an authorized distributor/dealer for service if fuse blows repeatedly. Check the connections. Replace the fuse. Contact an authorized distributor/dealer for service if fuse blows repeatedly. Replace the fuse. Contact an authorized distributor/dealer for service if fuse blows repeatedly. Move the master switch to the RUN position.
The generator set cranks but does not start, starts hard, lacks power, or operates erratically.	Air cleaner clogged Battery weak or dead Battery connection poor Spark plug wire connection loose Low oil pressure shutdown Fuel pressure insufficient Engine malfunction	Clean and/or replace the air cleaner. Check power to the battery charger. Recharge or replace the battery. Clean and tighten the battery connections. Check the spark plug wires. Check the oil level. Check the fuel supply and valves. Contact the distributor/dealer.
No AC output.	AC circuit breaker in the OFF position AC circuit breaker tripping because of overload AC circuit breaker tripping because of short circuit Auxiliary winding fuse (F1) blown	Place the circuit breaker in the ON position. Reduce the load on the generator set. Contact an authorized distributor/dealer for service. Replace the fuse. Contact an authorized distributor/dealer for service if fuse blows repeatedly.
Low output or excessive drop in voltage.	Generator set overloaded	Reduce the load.
Generator set stops suddenly.	Low oil pressure shutdown Out of fuel Overcrank shutdown Controller fuse (F3) blown Overspeed shutdown Generator set master switch in the OFF/RESET position Remote stop command received from a remote switch or ATS Engine malfunction Auxiliary winding fuse (F1) blown	Check the oil level. Check fuel supply. Reset the controller. If the overcrank fault occurs again, contact the distributor/dealer. Replace the fuse. If the fuse blows again, contact the distributor/dealer. Reset the controller. If the overspeed fault occurs again, contact the distributor/dealer. Move the switch to the correct position (RUN or AUTO). Check the remote switch position. Contact the distributor/dealer. Replace the fuse. Contact an authorized distributor/dealer for service if fuse blows repeatedly.

Figure 4-1 General Troubleshooting Chart

### 4.3 Fault Codes

The Advanced Digital Control displays fault codes to aid in troubleshooting. Fault codes, descriptions, and recommended actions are listed in Figure 2-3.

Identify and correct the cause of the fault condition. Then reset the controller after a fault shutdown. See Section 2.4.1.

### 4.4 Troubleshooting

Figure 4-2 contains troubleshooting, diagnostic, and repair information for the Advanced Digital Control.

### 4.5 Battery Charger Troubleshooting

Use the battery charger’s LED indicators and the table in Figure 4-3 to troubleshoot battery charger operation problems.

Problem	Possible Cause	Corrective Action
Controller LED display is off	No power to the controller:  Continuous power mode jumper is disconnected and the generator set has not run for 48 hours or longer.	Controller display will automatically activate when a remote start command is received or the generator set master switch is moved to the RUN position. See Section 2.5. Connect the jumper to maintain continuous power to the controller, if desired.
	Controller fuse (F3) is blown.	Replace the fuse. If the fuse blows again, contact the distributor/dealer.
	Low or no battery voltage.	Check connections. Check generator set battery and battery charger. See Figure 4-1.
	Generator set master switch is in the OFF/RESET position.	Move generator set master switch to the AUTO or RUN position.
	Generator set master switch in AUTO but no start command has been received since last controller reset.	No action required (see Section 2.3.1). Controller display will activate when a remote start command is received or the generator set master switch is moved to the RUN position. Use the remote switch to start generator set and activate the controller display, if desired.

**Figure 4-2** ADC 2100 Troubleshooting Chart

Problem	Cause	Solution
Red LED stays on for more than 24 hours	One or more defective or damaged cells.	Load test the battery and replace, if necessary
	Battery charger has reduced its output voltage below the normal level due to a DC overload or a DC short.	Remove the source of the overload or short. Disconnect the battery charger’s black (NEGATIVE) ring terminal from the battery. Reapply AC power and the green LED only should now light.
	Onboard DC systems are drawing more current than the battery charger can replace.	Turn off all DC equipment while charging.
Red and green LEDs stay on for more than 24 hours	Onboard DC systems are drawing between 1.5 and 5 amps.	Turn off all DC equipment while charging.
	One or more defective or damaged cells.	Load test the battery and replace, if necessary
	Extremely low AC voltage at the battery charger.	Apply a higher AC voltage source or reduce the length of the extension cord.
Green LED stays on when the battery is known to be low	Open DC output fuse.	Replace AGS-10 fuse.
	Faulty or contaminated terminal connections.	Clean and tighten or repair all terminal connections.
	One or more defective or damaged cells.	Load test the battery and replace, if necessary.
Neither of the LEDs turn on when the AC power is applied	No AC power available at the battery charger.	Connect AC power or reset the AC breaker on the main panel.
	Component failure.	Replace battery charger.

**Figure 4-3** Battery Charger Troubleshooting



# Appendix A Abbreviations

The following list contains abbreviations that may appear in this publication.

A, amp	ampere	cfh	cubic feet per hour	est.	estimated
ABDC	after bottom dead center	cfm	cubic feet per minute	E-Stop	emergency stop
AC	alternating current	CG	center of gravity	etc.	et cetera (and so forth)
A/D	analog to digital	CID	cubic inch displacement	exh.	exhaust
ADC	analog to digital converter	CL	centerline	ext.	external
adj.	adjust, adjustment	cm	centimeter	F	Fahrenheit, female
ADV	advertising dimensional drawing	CMOS	complementary metal oxide substrate (semiconductor)	fglass.	fiberglass
AHWT	anticipatory high water temperature	cogen.	cogeneration	FHM	flat head machine (screw)
AISI	American Iron and Steel Institute	com	communications (port)	fl. oz.	fluid ounce
ALOP	anticipatory low oil pressure	coml	commercial	flex.	flexible
alt.	alternator	Coml/Rec	Commercial/Recreational	freq.	frequency
Al	aluminum	conn.	connection	FS	full scale
ANSI	American National Standards Institute (formerly American Standards Association, ASA)	cont.	continued	ft.	foot, feet
AO	anticipatory only	CPVC	chlorinated polyvinyl chloride	ft. lbs.	foot pounds (torque)
API	American Petroleum Institute	crit.	critical	ft./min.	feet per minute
approx.	approximate, approximately	CRT	cathode ray tube	g	gram
AR	as required, as requested	CSA	Canadian Standards Association	ga.	gauge (meters, wire size)
AS	as supplied, as stated, as suggested	CT	current transformer	gal.	gallon
ASE	American Society of Engineers	Cu	copper	gen.	generator
ASME	American Society of Mechanical Engineers	cu. in.	cubic inch	genset	generator set
assy.	assembly	cw.	clockwise	GFI	ground fault interrupter
ASTM	American Society for Testing Materials	CWC	city water-cooled	GND, ⊕	ground
ATDC	after top dead center	cyl.	cylinder	gov.	governor
ATS	automatic transfer switch	D/A	digital to analog	gph	gallons per hour
auto.	automatic	DAC	digital to analog converter	gpm	gallons per minute
aux.	auxiliary	dB	decibel	gr.	grade, gross
A/V	audiovisual	dBA	decibel (A weighted)	GRD	equipment ground
avg.	average	DC	direct current	gr. wt.	gross weight
AVR	automatic voltage regulator	DCR	direct current resistance	H x W x D	height by width by depth
AWG	American Wire Gauge	deg., °	degree	HC	hex cap
AWM	appliance wiring material	dept.	department	HCHT	high cylinder head temperature
bat.	battery	dia.	diameter	HD	heavy duty
BBDC	before bottom dead center	DI/EO	dual inlet/end outlet	HET	high exhaust temperature, high engine temperature
BC	battery charger, battery charging	DIN	Deutsches Institut fur Normung e. V. (also Deutsche Industrie Normenausschuss)	hex	hexagon
BCA	battery charging alternator	DIP	dual inline package	Hg	mercury (element)
BCI	Battery Council International	DPDT	double-pole, double-throw	HH	hex head
BDC	before dead center	DPST	double-pole, single-throw	HHC	hex head cap
BHP	brake horsepower	DS	disconnect switch	HP	horsepower
blk.	black (paint color), block (engine)	DSAM	digital spark-advance module	hr.	hour
blk. htr.	block heater	DVR	digital voltage regulator	HS	heat shrink
BMEP	brake mean effective pressure	E, emer.	emergency (power source)	hsg.	housing
bps	bits per second	EDI	electronic data interchange	HVAC	heating, ventilation, and air conditioning
br.	brass	EFR	emergency frequency relay	HWT	high water temperature
BTDC	before top dead center	e.g.	for example ( <i>exempli gratia</i> )	Hz	hertz (cycles per second)
Btu	British thermal unit	EG	electronic governor	IC	integrated circuit
Btu/min.	British thermal units per minute	EGSA	Electrical Generating Systems Association	ID	inside diameter, identification
C	Celsius, centigrade	EIA	Electronic Industries Association	IEC	International Electrotechnical Commission
cal.	calorie	EI/EO	end inlet/end outlet	IEEE	Institute of Electrical and Electronics Engineers
CARB	California Air Resources Board	EMI	electromagnetic interference	IMS	improved motor starting
CB	circuit breaker	emiss.	emission	in.	inch
cc	cubic centimeter	eng.	engine	in. H <sub>2</sub> O	inches of water
CCA	cold cranking amps	EPA	Environmental Protection Agency	in. Hg	inches of mercury
ccw.	counterclockwise	EPS	emergency power system	in. lbs.	inch pounds
CEC	Canadian Electrical Code	ER	emergency relay	Inc.	incorporated
cert.	certificate, certification, certified	ES	engineering special, engineered special	ind.	industrial
		ESD	electrostatic discharge	int.	internal

ISO	International Organization for Standardization	MS	military standard	RH	round head
J	joule	m/sec.	meters per second	RHM	round head machine (screw)
JIS	Japanese Industry Standard	MTBF	mean time between failure	rly.	relay
k	kilo (1000)	MTBO	mean time between overhauls	rms	root mean square
K	kelvin	mtg.	mounting	rnd.	round
kA	kiloampere	MW	megawatt	ROM	read only memory
KB	kilobyte (2 <sup>10</sup> bytes)	mW	milliwatt	rot.	rotate, rotating
kg	kilogram	μF	microfarad	rpm	revolutions per minute
kg/cm <sup>2</sup>	kilograms per square centimeter	N, norm.	normal (power source)	RS	right side
kgm	kilogram-meter	NA	not available, not applicable	RTV	room temperature vulcanization
kg/m <sup>3</sup>	kilograms per cubic meter	nat. gas	natural gas	SAE	Society of Automotive Engineers
kHz	kilohertz	NBS	National Bureau of Standards	scfm	standard cubic feet per minute
kJ	kilojoule	NC	normally closed	SCR	silicon controlled rectifier
km	kilometer	NEC	National Electrical Code	s, sec.	second
kOhm, kΩ	kilo-ohm	NEMA	National Electrical Manufacturers Association	SI	<i>Système international d'unites</i> , International System of Units
kPa	kilopascal	NFPA	National Fire Protection Association	SI/EO	side in/end out
kph	kilometers per hour	Nm	newton meter	sil.	silencer
kV	kilovolt	NO	normally open	SN	serial number
kVA	kilovolt ampere	no., nos.	number, numbers	SPDT	single-pole, double-throw
kVAR	kilovolt ampere reactive	NPS	National Pipe, Straight	SPST	single-pole, single-throw
kW	kilowatt	NPSC	National Pipe, Straight-coupling	spec, specs	specification(s)
kWh	kilowatt-hour	NPT	National Standard taper pipe thread per general use	sq.	square
kWm	kilowatt mechanical	NPTF	National Pipe, Taper-Fine	sq. cm	square centimeter
L	liter	NR	not required, normal relay	sq. in.	square inch
LAN	local area network	ns	nanosecond	SS	stainless steel
L x W x H	length by width by height	OC	overcrank	std.	standard
lb.	pound, pounds	OD	outside diameter	stl.	steel
lbm/ft <sup>3</sup>	pounds mass per cubic feet	OEM	original equipment manufacturer	tach.	tachometer
LCB	line circuit breaker	OF	overfrequency	TD	time delay
LCD	liquid crystal display	opt.	option, optional	TDC	top dead center
ld. shd.	load shed	OS	oversize, overspeed	TDEC	time delay engine cooldown
LED	light emitting diode	OSHA	Occupational Safety and Health Administration	TDEN	time delay emergency to normal
Lph	liters per hour	OV	overvoltage	TDES	time delay engine start
Lpm	liters per minute	oz.	ounce	TDNE	time delay normal to emergency
LOP	low oil pressure	p., pp.	page, pages	TDOE	time delay off to emergency
LP	liquefied petroleum	PC	personal computer	TDON	time delay off to normal
LPG	liquefied petroleum gas	PCB	printed circuit board	temp.	temperature
LS	left side	pF	picofarad	term.	terminal
L <sub>wa</sub>	sound power level, A weighted	PF	power factor	TIF	telephone influence factor
LWL	low water level	ph., ∅	phase	TIR	total indicator reading
LWT	low water temperature	PHC	Phillips head crimplite (screw)	tol.	tolerance
m	meter, milli (1/1000)	PHH	Phillips hex head (screw)	turbo.	turbocharger
M	mega (10 <sup>6</sup> when used with SI units), male	PHM	pan head machine (screw)	typ.	typical (same in multiple locations)
m <sup>3</sup>	cubic meter	PLC	programmable logic control	UF	underfrequency
m <sup>3</sup> /min.	cubic meters per minute	PMG	permanent-magnet generator	UHF	ultrahigh frequency
mA	milliampere	pot	potentiometer, potential	UL	Underwriter's Laboratories, Inc.
man.	manual	ppm	parts per million	UNC	unified coarse thread (was NC)
max.	maximum	PROM	programmable read-only memory	UNF	unified fine thread (was NF)
MB	megabyte (2 <sup>20</sup> bytes)	psi	pounds per square inch	univ.	universal
MCM	one thousand circular mils	pt.	pint	US	undersize, underspeed
MCCB	molded-case circuit breaker	PTC	positive temperature coefficient	UV	ultraviolet, undervoltage
meggar	megohmmeter	PTO	power takeoff	V	volt
MHz	megahertz	PVC	polyvinyl chloride	VAC	volts alternating current
mi.	mile	qt.	quart, quarts	VAR	voltampere reactive
mil	one one-thousandth of an inch	qty.	quantity	VDC	volts direct current
min.	minimum, minute	R	replacement (emergency) power source	VFD	vacuum fluorescent display
misc.	miscellaneous	rad.	radiator, radius	VGA	video graphics adapter
MJ	megajoule	RAM	random access memory	VHF	very high frequency
mJ	millijoule	RDO	relay driver output	W	watt
mm	millimeter	ref.	reference	WCR	withstand and closing rating
mOhm, mΩ	milliohm	rem.	remote	w/	with
MOhm, MΩ	megohm	Res/Coml	Residential/Commercial	w/o	without
MOV	metal oxide varistor	RFI	radio frequency interference	wt.	weight
MPa	megapascal			xfmr	transformer
mpg	miles per gallon				
mph	miles per hour				



**TP-6331 5/04**

© 2004 by Kohler Co. All rights reserved.

# **KOHLER**<sup>®</sup> POWER SYSTEMS

KOHLER CO. Kohler, Wisconsin 53044  
Phone 920-565-3381, Fax 920-459-1646  
For the nearest sales/service outlet in the  
US and Canada, phone 1-800-544-2444  
[KohlerPowerSystems.com](http://KohlerPowerSystems.com)

Kohler Power Systems  
Asia Pacific Headquarters  
7 Jurong Pier Road  
Singapore 619159  
Phone (65)264-6422, Fax (65)264-6455