

Installation

Residential/Light Commercial Generator Sets



Models:

38RCL

48RCL

48RCLA

60RCL

Controller:

RDC2



KOHLER[®]
Power Systems

TP-6809 7/16d

California Proposition 65

⚠ WARNING

Engine exhaust from this product contains chemicals known to the State of California to cause cancer, birth defects, or other reproductive harm.

California Proposition 65

⚠ WARNING

This product contains and/or emits chemicals known to the State of California to cause cancer, birth defects, or other reproductive harm.

**Kohler strongly recommends
that only factory-authorized
distributors or dealers install
and service the generator.**

Product Identification Information

Product identification numbers determine service parts. Record the product identification numbers in the spaces below immediately after unpacking the products so that the numbers are readily available for future reference. Record field-installed kit numbers after installing the kits.

Generator Set Identification Numbers

Record the product identification numbers from the generator set nameplate(s).

Model Designation _____

Specification Number _____

Serial Number _____

Controller Identification

Record the controller description from the generator set operation manual, spec sheet, or sales invoice.

Controller Description _____

Engine Identification

Record the product identification information from the engine nameplate.

Manufacturer _____

Model Designation _____

Serial Number _____

Accessory Number

Accessory Description

_____	_____
_____	_____
_____	_____
_____	_____
_____	_____
_____	_____
_____	_____
_____	_____
_____	_____
_____	_____
_____	_____
_____	_____
_____	_____
_____	_____
_____	_____

Table of Contents

Safety Precautions and Instructions	5
Introduction	9
Service Assistance	10
Section 1 Installation Instructions	11
1.1 Introduction	11
1.2 Lifting Generator Set	12
1.3 Location and Mounting	14
1.3.1 Location Factors	14
1.3.2 Mounting Surface	14
1.3.3 Vibration Isolation	15
1.3.4 Prepare Site	15
1.3.5 Mount the Generator Set	15
1.4 Electrical System	16
1.4.1 Electrical Connections	17
1.4.2 Terminal Connector Torque	18
1.4.3 Ground and Neutral Connections	19
1.4.4 Battery Chargers	19
1.4.5 Power Supply	19
1.4.6 Connect AC and DC Wiring	20
1.4.7 Automatic Transfer Switch Connection	22
1.4.8 Communication Cable Specifications	25
1.4.9 Accessory Module RBUS Communication Connections	26
1.4.10 Other Accessories	29
1.5 Engine Starting Battery	29
1.6 Fuel System	30
1.6.1 Fuel Lines	31
1.6.2 Gas Regulators	32
1.6.3 Install and Connect Fuel Supply	32
1.6.4 Fuel Conversion Procedures	33
1.7 Cooling System	34
1.8 Prestart Installation Check	35
1.9 Set Exerciser	35
1.10 Operation Tests	36
1.11 OnCue Plus Generator Management System	36
Section 2 Accessories	37
2.1 Introduction	37
2.2 Block Heaters	37
2.3 Programmable Interface Module (PIM)	38
2.3.1 PIM to Generator Set Connections	38
2.3.2 PIM Inputs and Outputs	38
2.4 Load Management	39
2.4.1 Power Relay Module	39
Section 3 Generator Reconnection	41
3.1 Voltage Reconnection	41
3.2 Four-Lead (Single-Phase) Generator Sets	42
3.3 12-Lead (Three-Phase) Generator Sets	42
3.4 Changing System Settings	45
3.5 Voltage Calibration	48
3.5.1 Calibration using the RDC2 Controller Keypad and Menus	48
3.5.2 Calibration Using SiteTech	50
Section 4 Diagrams and Drawings	53
Appendix A Abbreviations	61

Notes

Safety Precautions and Instructions

IMPORTANT SAFETY INSTRUCTIONS. Electromechanical equipment, including generator sets, transfer switches, switchgear, and accessories, can cause bodily harm and pose life-threatening danger when improperly installed, operated, or maintained. To prevent accidents be aware of potential dangers and act safely. Read and follow all safety precautions and instructions. **SAVE THESE INSTRUCTIONS.**

This manual has several types of safety precautions and instructions: Danger, Warning, Caution, and Notice.

DANGER

Danger indicates the presence of a hazard that **will cause severe personal injury, death, or substantial property damage.**

WARNING

Warning indicates the presence of a hazard that **can cause severe personal injury, death, or substantial property damage.**

CAUTION

Caution indicates the presence of a hazard that **will or can cause minor personal injury or property damage.**

NOTICE

Notice communicates installation, operation, or maintenance information that is safety related but not hazard related.

Safety decals affixed to the equipment in prominent places alert the operator or service technician to potential hazards and explain how to act safely. The decals are shown throughout this publication to improve operator recognition. Replace missing or damaged decals.

Accidental Starting

WARNING

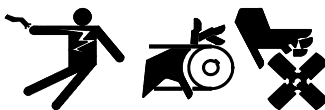

**Accidental starting.
Can cause severe injury or death.**

Disconnect the battery cables before working on the generator set. Remove the negative (-) lead first when disconnecting the battery. Reconnect the negative (-) lead last when reconnecting the battery.

Disabling the generator set. Accidental starting can cause severe injury or death. Before working on the generator set or equipment connected to the set, disable the generator set as follows: (1) Press the generator set off/reset button to shut down the generator set. (2) Disconnect the power to the battery charger, if equipped. (3) Remove the battery cables, negative (-) lead first. Reconnect the negative (-) lead last when reconnecting the battery. Follow these precautions to prevent the starting of the generator set by the remote start/stop switch.

Battery

WARNING



**Sulfuric acid in batteries.
Can cause severe injury or death.**

Wear protective goggles and clothing. Battery acid may cause blindness and burn skin.

WARNING



**Explosion.
Can cause severe injury or death.
Relays in the battery charger
cause arcs or sparks.**

Locate the battery in a well-ventilated area. Isolate the battery charger from explosive fumes.

Battery gases. Explosion can cause severe injury or death. Battery gases can cause an explosion. Do not smoke or permit flames or sparks to occur near a battery at any time, particularly when it is charging. Do not dispose of a battery in a fire. To prevent burns and sparks that could cause an explosion, avoid touching the battery terminals with tools or other metal objects. Remove all jewelry before servicing the equipment. Discharge static electricity from your body before touching batteries by first touching a grounded metal surface away from the battery. To avoid sparks, do not disturb the battery charger connections while the battery is charging. Always turn the battery charger off before disconnecting the battery connections. Ventilate the compartments containing batteries to prevent accumulation of explosive gases.

Battery electrolyte is a diluted sulfuric acid. Battery acid can cause severe injury or death. Battery acid can cause blindness and burn skin. Always wear splashproof safety goggles, rubber gloves, and boots when servicing the battery. Do not open a sealed battery or mutilate the battery case. If battery acid splashes in the eyes or on the skin, immediately flush the affected area for 15 minutes with large quantities of clean water. Seek immediate medical aid in the case of eye contact. Never add acid to a battery after placing the battery in service, as this may result in hazardous spattering of battery acid.

Battery short circuits. Explosion can cause severe injury or death. Short circuits can cause bodily injury and/or equipment damage. Disconnect the battery before generator set installation or maintenance. Remove all jewelry before servicing the equipment. Use tools with insulated handles. Remove the negative (-) lead first when disconnecting the battery. Reconnect the negative (-) lead last when reconnecting the battery. Never connect the negative (-) battery cable to the positive (+) connection terminal of the starter solenoid. Do not test the battery condition by shorting the terminals together.

Battery acid cleanup. Battery acid can cause severe injury or death. Battery acid is electrically conductive and corrosive. Add 500 g (1 lb.) of bicarbonate of soda (baking soda) to a container with 4 L (1 gal.) of water and mix the neutralizing solution. Pour the neutralizing solution on the spilled battery acid and continue to add the neutralizing solution to the spilled battery acid until all evidence of a chemical reaction (foaming) has ceased. Flush the resulting liquid with water and dry the area.

Engine Backfire/Flash Fire

⚠ WARNING

<p>Risk of fire. Can cause severe injury or death.</p> <p>Do not smoke or permit flames or sparks near fuels or the fuel system.</p>

Servicing the fuel system. A flash fire can cause severe injury or death. Do not smoke or permit flames or sparks near the carburetor, fuel line, fuel filter, fuel pump, or other potential sources of spilled fuels or fuel vapors. Catch fuels in an approved container when removing the fuel line or carburetor.

Servicing the air cleaner. A sudden backfire can cause severe injury or death. Do not operate the generator set with the air cleaner removed.

Combustible materials. A fire can cause severe injury or death. Generator set engine fuels and fuel vapors are flammable and explosive. Handle these materials carefully to minimize the risk of fire or explosion. Equip the compartment or nearby area with a fully charged fire extinguisher. Select a fire extinguisher rated ABC or BC for electrical fires or as recommended by the local fire code or an authorized agency. Train all personnel on fire extinguisher operation and fire prevention procedures.

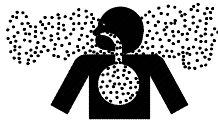
Exhaust System

⚠ WARNING

<p>Carbon monoxide. Can cause severe nausea, fainting, or death.</p> <p>The exhaust system must be leakproof and routinely inspected.</p>

Generator set operation. Carbon monoxide can cause severe nausea, fainting, or death. Carbon monoxide is an odorless, colorless, tasteless, nonirritating gas that can cause death if inhaled for even a short time. Avoid breathing exhaust fumes when working on or near the generator set. Never operate the generator set inside a building. Never operate the generator set where exhaust gas could seep inside or be drawn into a potentially occupied building through windows, air intake vents, or other openings.

Carbon monoxide detectors. Carbon monoxide can cause severe nausea, fainting, or death. Install carbon monoxide detectors on each level of any building adjacent to the generator set. Locate the detectors to adequately warn the building's occupants of the presence of carbon monoxide. Keep the detectors operational at all times. Periodically test and replace the carbon monoxide detectors according to the manufacturer's instructions.

Carbon monoxide symptoms. Carbon monoxide can cause severe nausea, fainting, or death. Carbon monoxide is a poisonous gas present in exhaust gases. Carbon monoxide is an odorless, colorless, tasteless, nonirritating gas that can cause death if inhaled for even a short time. Carbon monoxide poisoning symptoms include but are not limited to the following:

- Light-headedness, dizziness
- Physical fatigue, weakness in joints and muscles
- Sleepiness, mental fatigue, inability to concentrate or speak clearly, blurred vision
- Stomachache, vomiting, nausea

If experiencing any of these symptoms and carbon monoxide poisoning is possible, seek fresh air immediately and remain active. Do not sit, lie down, or fall asleep. Alert others to the possibility of carbon monoxide poisoning. Seek medical attention if the condition of affected persons does not improve within minutes of breathing fresh air.

Fuel System

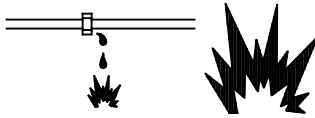
⚠ WARNING

<p>Explosive fuel vapors. Can cause severe injury or death.</p> <p>Use extreme care when handling, storing, and using fuels.</p>

The fuel system. Explosive fuel vapors can cause severe injury or death. Vaporized fuels are highly explosive. Use extreme care when handling and storing fuels. Store fuels in a well-ventilated area away from spark-producing equipment and out of the reach of children. Never add fuel to the tank while the engine is running because spilled fuel may ignite on contact with hot parts or from sparks. Do not smoke or permit flames or sparks to occur near sources of spilled fuel or fuel vapors. Keep the fuel lines and connections tight and in good condition. Do not replace flexible fuel

lines with rigid lines. Use flexible sections to avoid fuel line breakage caused by vibration. Do not operate the generator set in the presence of fuel leaks, fuel accumulation, or sparks. Repair fuel systems before resuming generator set operation.

Explosive fuel vapors can cause severe injury or death. Take additional precautions when using the following fuels:

Propane (LPG)—Adequate ventilation is mandatory. Because propane is heavier than air, install propane gas detectors low in a room. Inspect the detectors per the manufacturer's instructions.

Natural Gas—Adequate ventilation is mandatory. Because natural gas rises, install natural gas detectors high in a room. Inspect the detectors per the manufacturer's instructions.

Gas fuel leaks. Explosive fuel vapors can cause severe injury or death. Fuel leakage can cause an explosion. Check the LPG vapor or natural gas fuel system for leakage by using a soap and water solution with the fuel system test pressurized to 6–8 ounces per square inch (10–14 inches water column). Do not use a soap solution containing either ammonia or chlorine because both prevent bubble formation. A successful test depends on the ability of the solution to bubble.

Hazardous Noise

CAUTION







Hazardous noise.
Can cause hearing loss.



Never operate the generator set without a muffler or with a faulty exhaust system.

Engine noise. Hazardous noise can cause hearing loss. Generator sets not equipped with sound enclosures can produce noise levels greater than 105 dBA. Prolonged exposure to noise levels greater than 85 dBA can cause permanent hearing loss. Wear hearing protection when near an operating generator set.

Hazardous Voltage/ Moving Parts

 WARNING	
	
Hazardous voltage. Moving parts. Can cause severe injury or death.	
Operate the generator set only when all guards and electrical enclosures are in place.	

 WARNING	
	
Hazardous voltage. Backfeed to the utility system can cause property damage, severe injury, or death.	
If the generator set is used for standby power, install an automatic transfer switch to prevent inadvertent interconnection of standby and normal sources of supply.	

 CAUTION	
	
Welding the generator set. Can cause severe electrical equipment damage.	
Never weld components of the generator set without first disconnecting the battery, controller wiring harness, and engine electronic control module (ECM).	

Grounding electrical equipment. Hazardous voltage can cause severe injury or death. Electrocutation is possible whenever electricity is present. Ensure you comply with all applicable codes and standards. Electrically ground the generator set, transfer switch, and related equipment and electrical circuits. Turn off the main circuit breakers of all power sources before servicing the equipment. Never contact electrical leads or appliances when standing in water or on wet ground because these conditions increase the risk of electrocution.

Disconnecting the electrical load. Hazardous voltage can cause severe injury or death. Disconnect the generator set from the load by turning off the line circuit breaker or by disconnecting the generator set output leads from the transfer switch and heavily taping the ends of the leads. High voltage transferred to the load during testing may cause personal injury and equipment damage. Do not use the safeguard circuit breaker in place of the line circuit breaker. The safeguard circuit breaker does not disconnect the generator set from the load.

Welding on the generator set. Can cause severe electrical equipment damage. Before welding on the generator set perform the following steps: (1) Remove the battery cables, negative (-) lead first. (2) Disconnect all engine electronic control module (ECM) connectors. (3) Disconnect all generator set controller and voltage regulator circuit board connectors. (4) Disconnect the engine battery-charging alternator connections. (5) Attach the weld ground connection close to the weld location.

Installing the battery charger. Hazardous voltage can cause severe injury or death. An ungrounded battery charger may cause electrical shock. Connect the battery charger enclosure to the ground of a permanent wiring system. As an alternative, install an equipment grounding conductor with circuit conductors and connect it to the equipment grounding terminal or the lead on the battery charger. Install the battery charger as prescribed in the equipment manual. Install the battery charger in compliance with local codes and ordinances.

Connecting the battery and the battery charger. Hazardous voltage can cause severe injury or death. Reconnect the battery correctly, positive to positive and negative to negative, to avoid electrical shock and damage to the battery charger and battery(ies). Have a qualified electrician install the battery(ies).

Short circuits. Hazardous voltage/current can cause severe injury or death. Short circuits can cause bodily injury and/or equipment damage. Do not contact electrical connections with tools or jewelry while making adjustments or repairs. Remove all jewelry before servicing the equipment.

Engine block heater. Hazardous voltage can cause severe injury or death. The engine block heater can cause electrical shock. Remove the engine block heater plug from the electrical outlet before working on the block heater electrical connections.

Electrical backfeed to the utility. Hazardous backfeed voltage can cause severe injury or death. Install a transfer switch in standby power installations to prevent the connection of standby and other sources of power. Electrical backfeed into a utility electrical system can cause severe injury or death to utility personnel working on power lines.

Heavy Equipment

⚠ WARNING

<p>Unbalanced weight. Improper lifting can cause severe injury or death and equipment damage.</p> <p>Do not use lifting eyes. Lift the generator set using lifting bars inserted through the lifting holes on the skid.</p>

Hot Parts

⚠ WARNING

<p>Hot coolant and steam. Can cause severe injury or death.</p> <p>Before removing the pressure cap, stop the generator set and allow it to cool. Then loosen the pressure cap to relieve pressure.</p>

⚠ WARNING

<p>Hot engine and exhaust system. Can cause severe injury or death.</p> <p>Do not work on the generator set until it cools.</p>

⚠ WARNING

<p>Hot engine oil. Can cause severe injury or death.</p> <p>Avoid skin contact with hot oil. Do not start or operate the generator set with the engine oil filler cap removed, as hot oil can spray out. Ensure that the lubrication system is not under pressure when servicing. Do not work on the generator set until it cools.</p>

Servicing the exhaust system. Hot parts can cause severe injury or death. Do not touch hot engine parts. The engine and exhaust system components become extremely hot during operation.

Notice

NOTICE

Canadian installations only. For standby service connect the output of the generator set to a suitably rated transfer switch in accordance with Canadian Electrical Code, Part 1.

This manual provides installation instructions for the Model 38RCL, 48RCL, 48RCLA, and 60RCL generator sets. Operation manuals are available separately. See Figure 1 for an illustration of the 48RCL generator set.

Information in this publication represents data available at the time of print. Kohler Co. reserves the right to change this publication and the products represented without notice and without any obligation or liability whatsoever.

Read this manual and carefully follow all procedures and safety precautions to ensure proper equipment operation and to avoid bodily injury. Read and follow the Safety Precautions and Instructions section at the beginning of this manual. Keep this manual with the equipment for future reference.



Figure 1 Model 48RCL Generator Set

Warranty Registration

Complete the startup and installation checklists supplied with the startup notification form. Complete and sign the startup notification form and register the unit using the Kohler online Warranty Processing System.

List of Related Materials

Figure 2 identifies related literature available for the generator sets covered in this manual. Only trained and qualified personnel should install or service the generator set.

Literature Type	Part Number
Specification Sheet, 38RCL	G4-214
Specification Sheet, 48RCL	G4-211
Specification Sheet, 48RCLA	G4-263
Specification Sheet, 60RCL	G4-233
Operation Manual, Generator Set	TP-6810
Operation Manual, Engine	TP-6101
Service Manual, Generator Set	TP-6811
Service Manual, 38RCL Engine Mechanical	TP-6103
Service Manual, 48RCL, 48RCLA, 60RCL Engine Mechanical	TP-6104
Service Manual, Engine ECM Diagnostics	TP-6724
Service Manual, 38RCL Alternator	TP-6353
Service Manual, 48RCL, 48RCLA, 60RCL Alternator	TP-6783
Parts Catalog, 38RCL Engine	TP-6730
Parts Catalog, 48RCL, 48RCLA, 60RCL Engine	TP-6731
Parts Catalog, Generator Set	TP-6812
Accessory Literature	Part Number
Installation Instructions, Block Heaters	TT-1587
Installation Instructions, Load Shed Kit	TT-1609
Installation Instructions, Programmable Interface Module (PIM)	TT-1584
Installation Instructions, Power Relay Modules	TT-1646
User Guide, OnCue® Plus Program	TP-7006
Technical Manual, OnCue® Plus Program	TP-7007
Operation/Installation Manual, RXT ATS	TP-6807
Operation/Installation Manual, RDT ATS	TP-6345

Figure 2 Related Literature

Service Assistance

For professional advice on generator power requirements and conscientious service, please contact your nearest authorized Kohler distributor/dealer.

- Consult the Yellow Pages under the heading Generators—Electric.
- Visit the Kohler Power Systems website at KOHLERPower.com.
- Look at the labels and decals on your Kohler product or review the appropriate literature or documents included with the product.
- Call toll free in the US and Canada 1-800-544-2444.
- Outside the US and Canada, call the nearest regional office.

Headquarters Europe, Middle East, Africa (EMEA)

Kohler Power Systems Netherlands B.V.
Kristallaan 1
4761 ZC Zevenbergen
The Netherlands
Phone: (31) 168 331630
Fax: (31) 168 331631

Asia Pacific

Power Systems Asia Pacific Regional Office
Singapore, Republic of Singapore
Phone: (65) 6264-6422
Fax: (65) 6264-6455

China

North China Regional Office, Beijing
Phone: (86) 10 6518 7950
(86) 10 6518 7951
(86) 10 6518 7952
Fax: (86) 10 6518 7955

East China Regional Office, Shanghai
Phone: (86) 21 6288 0500
Fax: (86) 21 6288 0550

India, Bangladesh, Sri Lanka

India Regional Office
Bangalore, India
Phone: (91) 80 3366208
(91) 80 3366231
Fax: (91) 80 3315972

Japan, Korea

North Asia Regional Office
Tokyo, Japan
Phone: (813) 3440-4515
Fax: (813) 3440-2727

Section 1 Installation Instructions

1.1 Introduction

Review this entire section and the Safety Precautions before starting the installation procedure. The generator set specification sheet also contains data that may be required during the installation process.

The generator set and accessories must be installed by an authorized Kohler distributor/dealer or authorized representative. The installation must comply with the National Electrical Code (NEC) and local codes. For Canadian installations, refer to the Canadian Electrical Code (CEC).

Note: These instructions outline one procedure for installing the generator set. Local codes may require different procedures.



The generator set must be installed outdoors. The exhaust systems on enclosed units are designed for outdoor installation only.

Note: DO NOT install these generator sets inside a building.

Note: Install carbon monoxide (CO) detector(s) on each level of any building adjacent to a generator set. Locate the detectors to adequately warn the building's occupants of the presence of carbon monoxide.

Read and follow the safety precautions in this manual and observe the decals on the equipment. Refer to the diagrams and drawings in Section 4 for dimensions and electrical connections during the installation procedure. Read the entire installation procedure and obtain the accessories and tools needed before beginning installation. Perform the steps in the order shown.

To install optional accessories, follow the instructions provided with each kit.

 WARNING

<p>Hazardous voltage. Backfeed to the utility system can cause property damage, severe injury, or death.</p> <p>If the generator set is used for standby power, install an automatic transfer switch to prevent inadvertent interconnection of standby and normal sources of supply.</p>

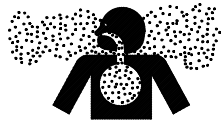
Grounding electrical equipment. Hazardous voltage can cause severe injury or death. Electrocutation is possible whenever electricity is present. Ensure you comply with all applicable codes and standards. Electrically ground the generator set, transfer switch, and related equipment and electrical circuits. Turn off the main circuit breakers of all power sources before servicing the equipment. Never contact electrical leads or appliances when standing in water or on wet ground because these conditions increase the risk of electrocution.

 WARNING

<p>Carbon monoxide. Can cause severe nausea, fainting, or death.</p> <p>The exhaust system must be leakproof and routinely inspected.</p>

Generator set operation. Carbon monoxide can cause severe nausea, fainting, or death. Carbon monoxide is an odorless, colorless, tasteless, nonirritating gas that can cause death if inhaled for even a short time. Avoid breathing exhaust fumes when working on or near the generator set. Never operate the generator set inside a building. Never operate the generator set where exhaust gas could seep inside or be drawn into a potentially occupied building through windows, air intake vents, or other openings.

Carbon monoxide detectors. Carbon monoxide can cause severe nausea, fainting, or death. Install carbon monoxide detectors on each level of any building adjacent to the generator set. Locate the detectors to adequately warn the building's occupants of the presence of carbon monoxide. Keep the detectors operational at all times. Periodically test and replace the carbon monoxide detectors according to the manufacturer's instructions.

Tools Required:

- Multimeter (for measuring voltage and current)
- Frequency meter (may be part of multimeter)
- Manometer (for measuring fuel pressure)
- Torque wrench
- Wrenches
- Screwdrivers
- Socket wrenches or nut drivers
- Pliers
- Safety glasses or goggles
- Drill with bits and hole saw

Installer/Customer-Supplied Items:

- One BCI group 24 size 12-volt battery with a minimum rating of 630 cold cranking amps (CCA) at 0°F
- Gravel or crushed stone
- Concrete mounting pad
- Cables and conduit
- Fuel supply line with shutoff valve and pipe sealant (provided by fuel supplier)
- Carbon monoxide (CO) detector(s)

Available Accessories:

- Battery
- Battery heater
- Block heater
- Flexible fuel lines
- Programmable Interface Module (PIM)
See TT-1584 for installation instructions.
- Load management system

1.2 Lifting Generator Set

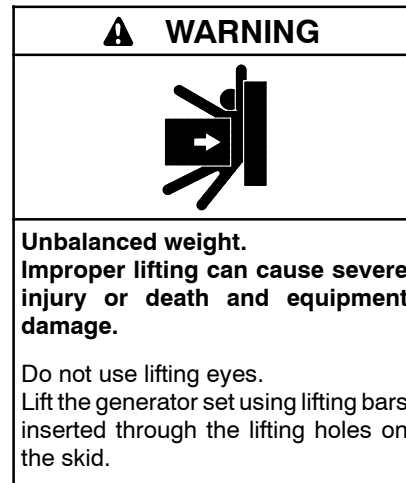

The approximate weight of the generator set with enclosure is shown in Figure 1-1. Use equipment that is rated for the generator set's weight to lift the unit into place. Lift the enclosure and generator set together as one unit.

Model	Weight, kg (lb.)
38RCL	726 (1600)
48RCL	862 (1900)
48RCLA	830 (1830)
60RCL	890 (1960)

Figure 1-1 Approximate Weights

Insert lifting bars through the four holes in the mounting skid. The placement of the holes maintains balance during lifting.

Follow these general precautions when lifting all generator sets and related equipment.

- Install proper size rigging at the skid lifting eyes providing a direct pull on the skid lifting eye. Make sure the rigging does not work as a pry bar lever against the lifting eye.
- **DO NOT** lift the generator set using the lifting eyes attached to the engine and/or alternator as these lifting eyes can not support the total weight of the generator set.
- **DO NOT** attach hoisting equipment to the enclosure. Insert lifting bars through the four holes in the mounting skid.
- Always protect cables, chains, and straps from sharp edges.
- Use a spreader bar to prevent lifting cables from contacting the enclosure.

- Lifting should only be conducted by those trained and experienced in lifting and rigging to achieve a safe and effective lift. Consideration needs to be given to, but not necessarily limited to the following items:
 - Weight and center of gravity of the equipment being lifted
 - Weight and center of gravity of the lifting device
 - Boom angles
 - Selection of rated rigging
 - Stability of lifting foundation
 - Wind and weather conditions
 - Local or regional codes that may require or restrict types of rigging.

The distributor/lifting contractor should choose one of the following methods to lift the generator set depending upon the location circumstances and the generator set's weight and size.

Single Spreader Bar and Skid Lifting Bar Method

Refer to Figure 1-3.

Double Spreader Bar and Skid Lifting Bar Method

Refer to Figure 1-4.

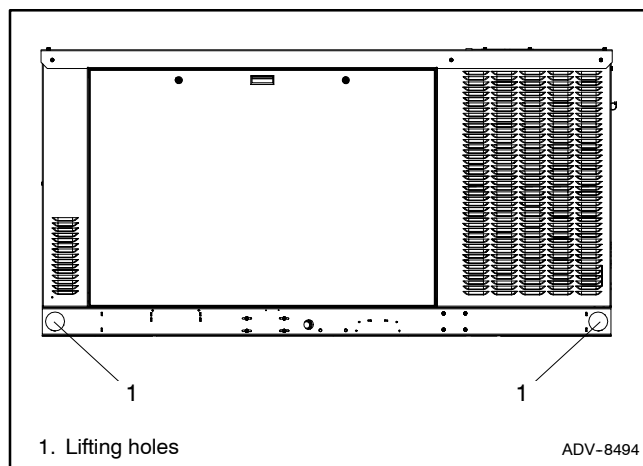

Figure 1-2 Typical Enclosure with Lifting Holes

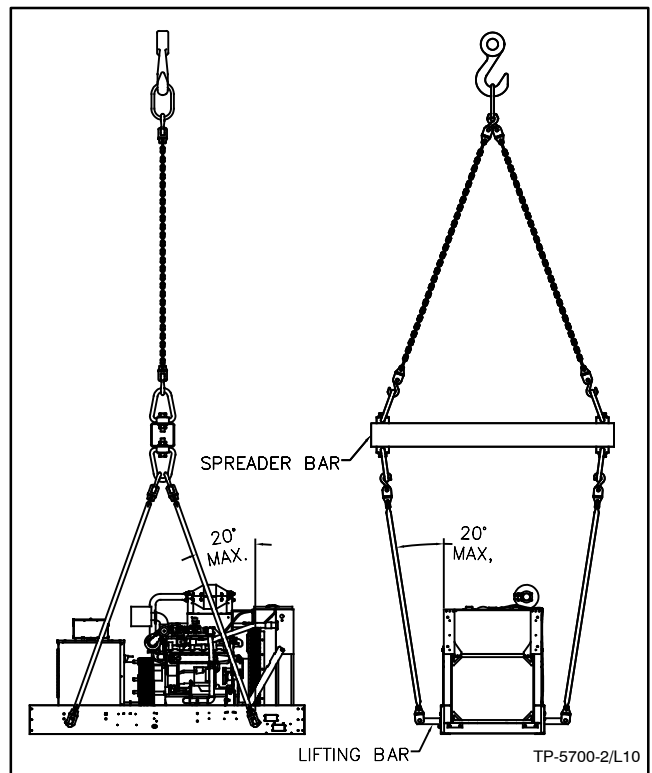

Figure 1-3 Single Spreader Bar and Skid Lifting Bar Method (enclosure not shown)

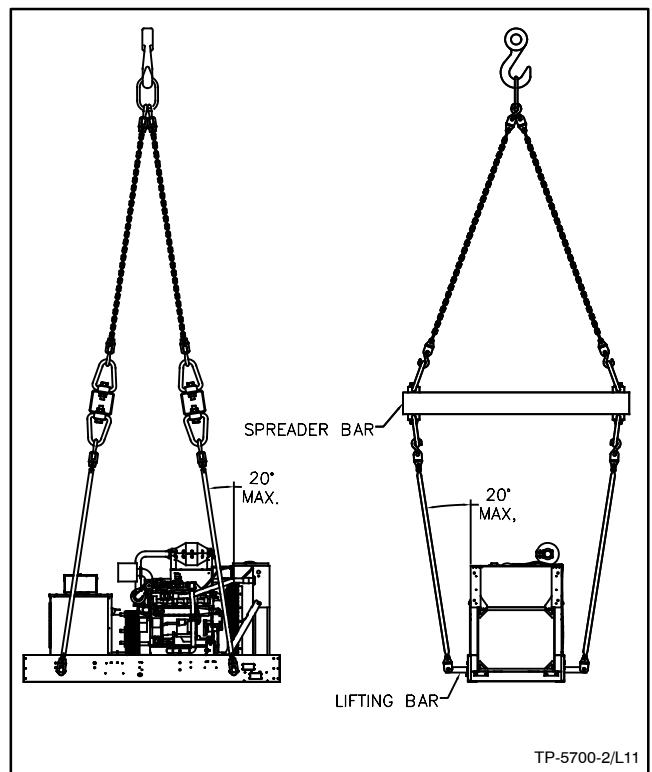

Figure 1-4 Double Spreader Bar and Skid Lifting Bar Method (enclosure not shown)

1.3 Location and Mounting

1.3.1 Location Factors

The manufacturer recommends mounting the generator set on concrete at ground level. For above-ground installations, including roof installations, weight considerations are especially important. The building engineer must determine whether the structure can support the weight of the generator set.

The location of the generator set must:

- Support the weight of the generator set and related equipment such as batteries, radiators, and mounting pad(s). Keep in mind that the mounting pad weight may exceed the weight of the generator set.
- Meet applicable fire rating codes and standards.
- Minimize the risk that people will come into contact with hot generator set surfaces.
- Position the generator set over a noncombustible surface. **DO NOT** allow accumulation of combustible materials under or around the generator set.
- Permit vibration isolation to reduce noise and prevent damage.
- Not be subject to flooding.
- Allow safe expulsion of exhaust.
- Provide clearance for cooling air flow and access for service. See Figure 1-5 and the dimension drawings in Section 4 for required minimum clearances from obstructions and combustible materials.
- Minimize the risk of public or unauthorized access.

Notice

DO NOT locate the generator set near patios, decks, play areas, or animal shelters. Keep items such as lawn furniture, toys, sports equipment, and all combustible materials away from the generator set exhaust outlet.

Remind family members, children, and visitors to use caution near the generator set. Generator sets connected to automatic transfer switches start automatically during exercise periods and power outages. Some generator set components become hot when the generator set is running and remain hot for a time after the generator set shuts down.

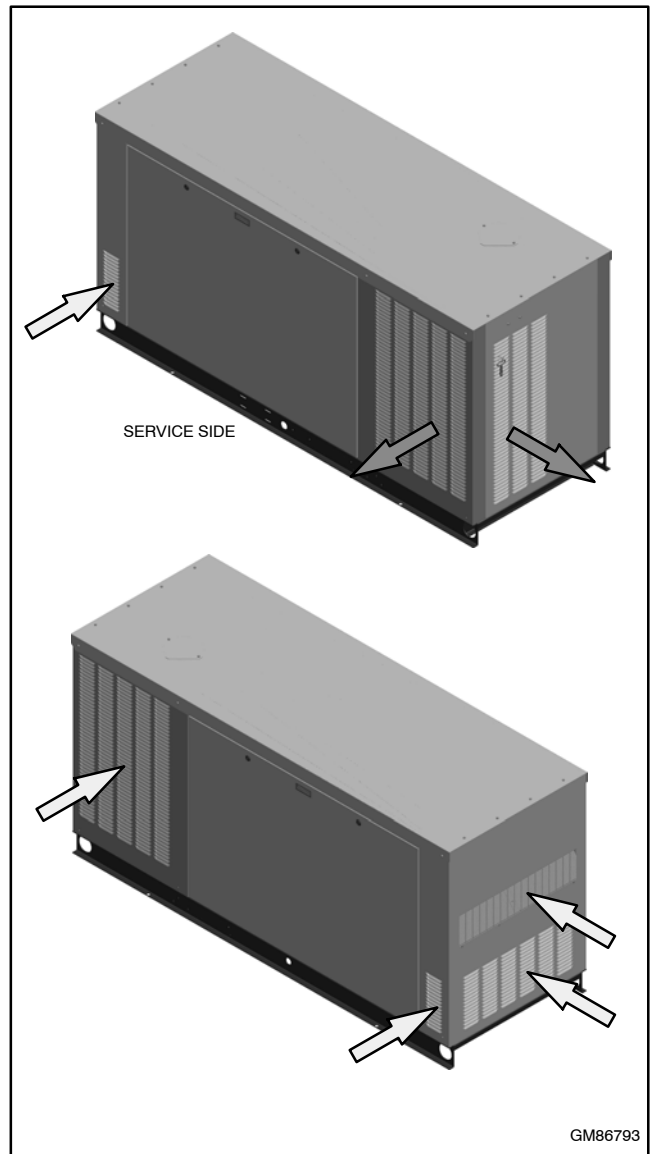

Figure 1-5 Air Intake and Exhaust

1.3.2 Mounting Surface

Install the generator set on a single, level concrete mounting pad. This method provides maximum stability and ensures correct cooling air flow through the generator set. The recommended mounting pad dimensions are shown in the dimension drawings in Section 4.

Refer to the generator set dimension drawings for conduit and fuel-line placement. The drawings give dimensions for electrical and fuel connection rough-ins and stub-ups.

1.3.3 Vibration Isolation

The generator set is equipped with neoprene vibration isolators. Connections between the generator set or its mounting base and any conduits or fuel lines must include flexible sections to prevent breakage and to isolate vibration.

1.3.4 Prepare Site

Choose a location that is at least 0.9 m (3 ft.) from any building or structure and near the incoming gas service. Allow a minimum of 2.4 m (8 ft.) clearance beyond the exhaust end of the generator set. Plan the installation so that the exhaust outlets of the generator set are not directed toward the building or any openings where exhaust gas could be drawn into the building.

Install carbon monoxide detectors on each level of any building adjacent to the generator set. Locate the detectors to adequately warn the building's occupants of the presence of carbon monoxide.

1. Obtain a building permit and contact your local utility companies to mark the locations of underground pipes and cables.
2. Prepare an area for mounting the generator set.
 - a. Clear all combustible materials, including plants and shrubs, building materials, and lawn furniture, from an area at least 2.4 m (8 ft.)

beyond the exhaust outlets of the generator set.

- b. Spread a 76 mm (3 in.) thick layer of gravel to support the concrete mounting pad. For the mounting pad dimensions, see the generator set dimension drawing in Section 4.
- c. Lay a 100 mm (4 in.) thick concrete pad on the gravel layer. Include mounting bolts and stub-ups for the fuel supply and electrical conduit. See the dimension drawing in Section 4 for the mounting bolt and stub-up locations.

1.3.5 Mount the Generator Set

Note: Read all safety precautions at the beginning of this publication before performing any work on the generator set.

1. Place the generator set on the concrete mounting pad. Secure the generator set with mounting bolts anchored in the concrete pad.
2. Remove the shipping bracket, which is attached to the skid under the engine and labeled with a hang tag.
3. Remove the enclosure doors and alternator-end panel to gain access to the junction box and other generator set components during installation. Remove the covers to access the AC and DC connection terminal blocks.

1.4 Electrical System

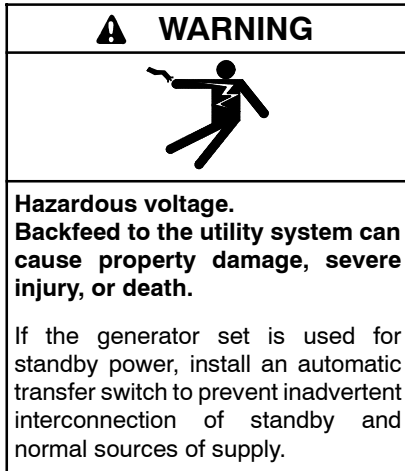
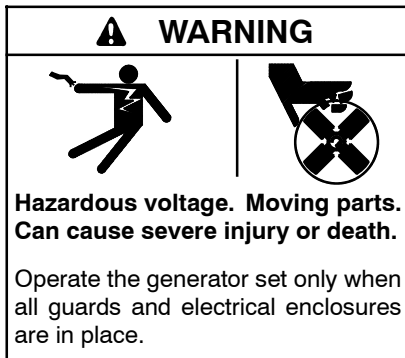

Grounding electrical equipment. Hazardous voltage can cause severe injury or death. Electrocutation is possible whenever electricity is present. Ensure you comply with all applicable codes and standards. Electrically ground the generator set, transfer switch, and related equipment and electrical circuits. Turn off the main circuit breakers of all power sources before servicing the equipment. Never contact electrical leads or appliances when standing in water or on wet ground because these conditions increase the risk of electrocution.

Disconnecting the electrical load. Hazardous voltage can cause severe injury or death. Disconnect the generator set from the load by turning off the line circuit breaker or by disconnecting the generator set output leads from the transfer switch and heavily taping the ends of the leads. High voltage transferred to the load during testing may cause personal injury and equipment damage. Do not use the safeguard circuit breaker in place of the line circuit breaker. The safeguard circuit breaker does not disconnect the generator set from the load.

Before installing the generator set, provide for electrical connections through conduit to the transfer switch and other accessories for the generator set. Route DC leads in separate conduit from AC conductors. Carefully install the selected generator set accessories. Route wiring to the generator set through flexible connections. Comply with all applicable codes when installing a wiring system.

See the dimension drawings in Section 4 for the recommended stub-up location.

AC circuit protection. All AC circuits must include circuit breaker or fuse protection. The circuit breaker must be rated for a maximum of 125% of the rated generator set output current. The circuit breaker must open all ungrounded connectors.

The generator set is equipped with a factory-installed circuit breaker.

1.4.1 Electrical Connections

Several electrical connections must be made between the generator set and other components of the system for proper operation. Most field-installed accessory kits include installation instructions. Comply with applicable national and local codes when installing a wiring system.

For Canadian installations, refer to the Canadian Electrical Code (CEC).

For customer-supplied wiring, select the wire temperature rating in Figure 1-6 based upon the following criteria:

- Select row 1, 2, 3, or 4 if the circuit rating is 110 amperes or less or requires #1 AWG (42.4 mm²) or smaller conductors.
- Select row 3 or 4 if the circuit rating is greater than 110 amperes or requires #1 AWG (42.4 mm²) or larger conductors.

Row	Temp. Rating	Copper (Cu) Only	Cu/Aluminum (Al) Combinations	Al Only
1	60°C (140°F) or 75°C (167°F)	Use No. * AWG, 60°C wire or use No. * AWG, 75°C wire	Use 60°C wire, either No. * AWG Cu, or No. * AWG Al or use 75°C wire, either No. * AWG Cu or No. * AWG Al	Use 60°C wire, No. * AWG or use 75°C wire, No. * AWG
2	60°C (140°F)	Use No. * AWG, 60°C wire	Use 60°C wire, either No. * AWG Cu or No. * AWG Al	Use 60°C wire, No. * AWG
3	75°C (167°F)	Use No. *† AWG, 75°C wire	Use 75°C wire, either No. *† AWG Cu or No. *† AWG Al	Use 75°C wire, No.*† AWG
4	90°C (194°F)	Use No. *† AWG, 90°C wire	Use 90°C wire, either No. *† AWG Cu or No. *† AWG Al	Use 90°C wire, No.*† AWG

* The wire size for 60°C (140°F) wire is not required to be included in the marking. If included, the wire size is based on ampacities for the wire given in Table 310-16 of the National Electrical Code®, in ANSI/NFPA 70, and on 115% of the maximum current that the circuit carries under rated conditions. The National Electrical Code® is a registered trademark of the National Fire Protection Association, Inc.

† Use the larger of the following conductors: the same size conductor as that used for the temperature test or one selected using the guidelines in the preceding footnote.

Figure 1-6 Terminal Markings for Various Temperature Ratings and Conductors

1.4.2 Terminal Connector Torque

Use the torque values shown in Figure 1-7 or Figure 1-8 for terminal connectors. Refer to UL-486A, UL-486B, and UL-486E for information on terminal connectors for aluminum and/or copper conductors. Comply with applicable national and local codes when installing a wiring system.

Note: If a connector has a clamp screw such as a slotted, hexagonal head screw with more than one means of tightening, test the connector using both applicable torque values provided in Figure 1-8.

Socket Size Across Flats, mm (in.)	Tightening Torque, Nm (in. lb.)
3.2 (1/8)	5.1 (45)
4.0 (5/32)	11.4 (100)
4.8 (3/16)	13.8 (120)
5.6 (7/32)	17.0 (150)
6.4 (1/4)	22.6 (200)
7.9 (5/16)	31.1 (275)
9.5 (3/8)	42.4 (375)
12.7 (1/2)	56.5 (500)
14.3 (9/16)	67.8 (600)
Note: For values of slot width or length not corresponding to those specified, select the largest torque value associated with the conductor size. Slot width is the nominal design value. Slot length is to be measured at the bottom of the slot.	

Figure 1-7 Tightening Torque for Pressure Wire Connectors with Internal-Drive Socket-Head Screws

Wire Size for Unit Connection	Tightening Torque, Nm (in. lb.)			
	Slot Head 4.7 mm (No. 10) or Larger*		Hexagonal Head—External Drive Socket Wrench	
	Slot Width <1.2 mm (0.047 in.) Slot Length <6.4 mm (0.25 in.)	Slot Width >1.2 mm (0.047 in.) Slot Length >6.4 mm (0.25 in.)	Split-Bolt Connectors	Other Connections
18-10 (0.82-5.3)	2.3 (20)	4.0 (35)	9.0 (80)	8.5 (75)
8 (8.4)	2.8 (25)	4.5 (40)	9.0 (80)	8.5 (75)
6-4 (13.3-21.2)	4.0 (35)	5.1 (45)	18.6 (165)	12.4 (110)
3 (26.7)	4.0 (35)	5.6 (50)	31.1 (275)	16.9 (150)
2 (33.6)	4.5 (40)	5.6 (50)	31.1 (275)	16.9 (150)
1 (42.4)	—	5.6 (50)	31.1 (275)	16.9 (150)
1/0-2/0 (53.5-67.4)	—	5.6 (50)	43.5 (385)	20.3 (180)
3/0-4/0 (85.0-107.2)	—	5.6 (50)	56.5 (500)	28.2 (250)
250-350 (127-177)	—	5.6 (50)	73.4 (650)	36.7 (325)
400 (203)	—	5.6 (50)	93.2 (825)	36.7 (325)
500 (253)	—	5.6 (50)	93.2 (825)	42.4 (375)
600-750 (304-380)	—	5.6 (50)	113.0 (1000)	42.4 (375)
800-1000 (406-508)	—	5.6 (50)	124.3 (1100)	56.5 (500)
1250-2000 (635-1016)	—	—	124.3 (1100)	67.8 (600)
* For values of slot width or length not corresponding to those specified, select the largest torque value associated with the conductor size. Slot width is the nominal design value. Slot length is to be measured at the bottom of the slot.				
Note: If a connector has a clamp screw such as a slotted, hexagonal head screw with more than one means of tightening, test the connector using both applicable torque values.				

Figure 1-8 Tightening Torque for Screw-Type Pressure Wire Connectors

1.4.3 Ground and Neutral Connections

Ground the generator set. The grounding method must comply with NEC and local codes. Connect the ground to the generator set ground lug, terminal GRD inside the junction box (see Figure 1-10). Connect the grounds for utility and low voltage connections to the ground lugs provided in the customer connection box for those specific connections (see Figure 1-10).

Various regulations and site configurations including the National Electrical Code (NEC), local codes, and the type of transfer switch used in the application determine the grounding of the neutral at the alternator. NEC 2002 Section 250.20 is one example that has a very good explanation of the neutral grounding requirements for generator sets.

Generator sets are shipped with the generator set neutral attached to the alternator in the junction box. At installation, the neutral can be grounded at the generator set or lifted from the ground stud and isolated if the installation requires an ungrounded neutral connection at the alternator. The generator set will operate properly with the neutral either bonded to ground or isolated from ground at the alternator.

1.4.4 Battery Chargers

An engine-driven, battery-charging alternator charges the battery whenever the generator set operates. Engine-driven systems can quickly restore the charge used in a normal cranking cycle.

When the engine is not operating, a very low charge rate from an AC-powered battery charger is usually sufficient to maintain a full charge on the batteries. The RDC2 controller contains a built-in battery charger to maintain the generator set's engine starting battery. Be sure to provide AC power for the integral battery charger as instructed in Section 1.4.5.

1.4.5 Power Supply

Power must be supplied to the generator set location for the battery charger and optional accessories. The power source must comply with both state and local codes. The power to the accessories must be available at all times, i.e. the circuit must be powered by the utility source and backed up by the generator set.

Connect power to the leads in the utility power connection area shown in Figure 1-10. See the wiring diagrams in Section 4 for connection details. See Figure 1-9 for the power requirements for the battery charger and accessories.

Equipment	Power Requirement		
	Watts	Amps	Volts
Battery charger (standard, integral to RDC2 controller)	50	0.42	120
Block heater (optional)	1500	12.5	120
		6.3	240
Battery heater (optional)	80	0.7	120

Figure 1-9 Power Requirements

1.4.6 Connect AC and DC Wiring

Note: Have a licensed electrician make the following electrical connections. All connections must comply with state and local codes.

Size the wire according to the length of run and 115% of the circuit current (amperage) based on 75°C wire rating or less as directed by the National Electrical Code® (NEC) in ANSI/NFPA 70. See Section 1.4.1 for additional information about wire selection.

The generator set is equipped with a field-connection terminal block located in the access area below the junction box. Leads have been factory-installed from the junction box to the terminal block for easy field wiring.

See Figure 1-10. Make all AC and DC customer connections inside the customer connection box. Do not remove the end panel or make connections inside the junction box. Refer to the wiring diagrams in Section 4.

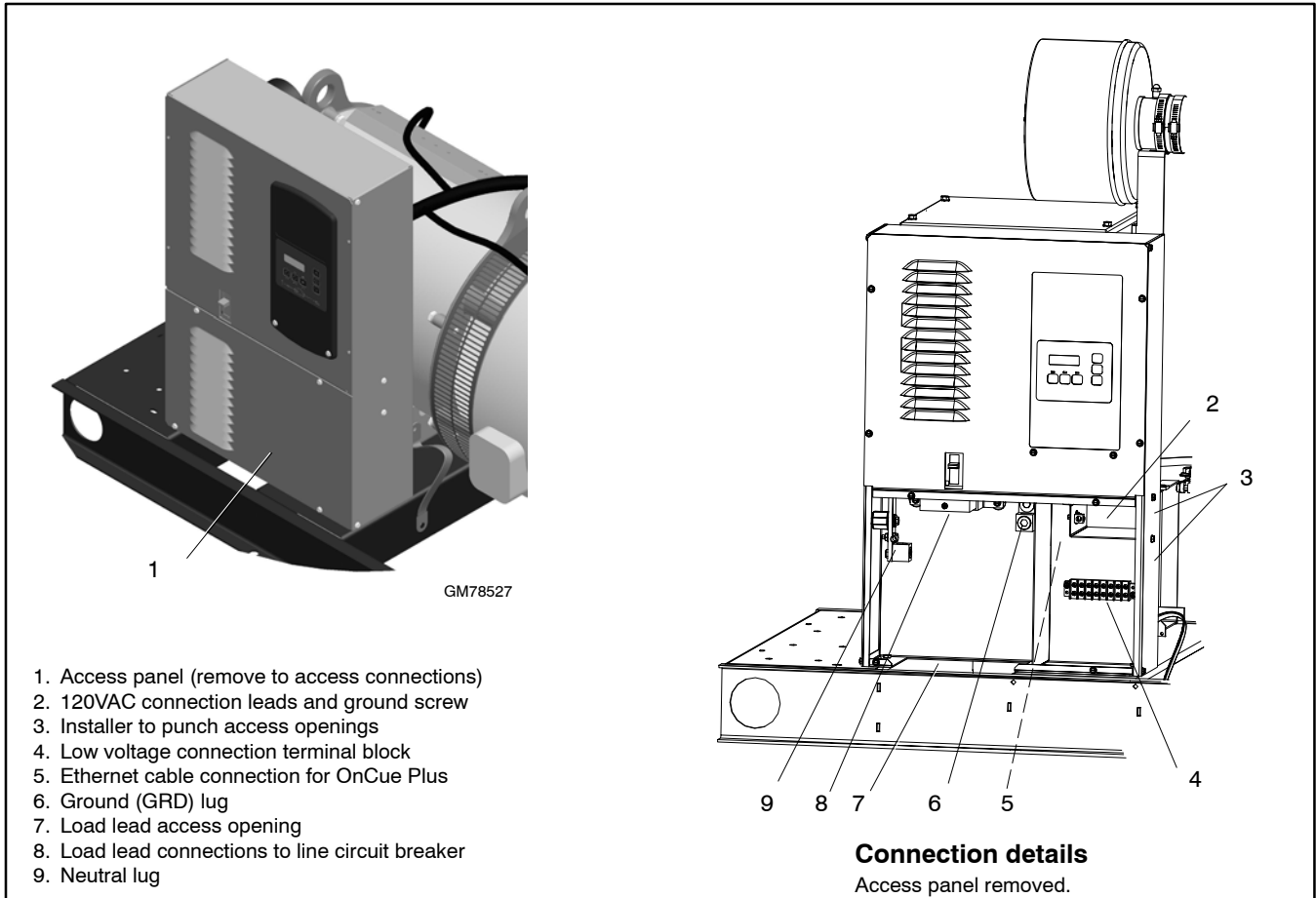

Figure 1-10 Generator Set Connections

Generator Set Connections

Note: Read all safety precautions at the beginning of this publication before performing any work on the generator set.

Use separate conduit for the power cables and the low voltage communication or engine start leads. Local codes and the length of run as well as the transfer switch wire size requirements will determine the wire size needed for the AC leads.

Note: Some codes require the use of a disconnect switch. Check the code requirements for your location and install a disconnect switch, if required.

1. Route the load leads into the junction box through the access opening in the bottom of the box. Connect the load leads from the line circuit breaker in the generator set junction box to the transfer switch emergency power connection points. See Figure 1-10 and refer to transfer switch installation manual for ATS connection instructions.
2. Connect the neutral (L0) and ground (GRD) leads from the ATS and the main panel to the corresponding lugs in the connection box. See Section 1.4.3 for grounding information.
3. Cut or punch openings in the side of the connection box for the 120 VAC power supply leads and the low voltage connections. See Figure 1-10. Use separate conduit for the power leads and the low voltage leads.
4. Connect utility power for the controller's battery charger. Connect to a circuit that is supplied by the utility source and backed up by the generator. See Section 1.4.5 for more information about the utility power requirement.
5. For transfer switch communication and/or engine start connection, see Section 1.4.7.
6. For connection of the optional programmable interface module (PIM), and/or a load shed kit, see Section 1.4.9.

7. Install an AC receptacle for the optional AC accessories, if equipped. Power to this receptacle must be available when the generator set is not running.

Note: The OnCue® Plus Generator Management System kit for remote generator monitoring and control is included with Model RCL generator sets. The OnCue Plus system requires installation of a network cable from the generator to the owner's computer router.

8. To connect the OnCue® Plus Generator Management System to your generator, run network cable from the generator set to the customer's router or modem.
 - a. Route the network cable with other low-voltage signal wiring (for example, the RBUS communication leads or engine start leads to the transfer switch), in separate conduit from the AC load leads. If the network cable is longer than 100 meters (328 ft.), use a repeater or switch.
 - b. Test the Internet connection for the generator by connecting a laptop to the network cable.
 - (1) Turn OFF any wireless connections to the laptop.
 - (2) Connect the network cable to the laptop. Connect the other end of the network cable to the customer's router or modem.
 - (3) Verify the Internet connection by opening your web browser and going to www.kohlerpower.com or any known website.
 - (4) Disconnect the network cable from the laptop.
 - c. Use an RJ45 inline coupler to connect the Ethernet cable to the cable in the customer connection box. The inline coupler is included with the OnCue Plus kit.

1.4.7 Automatic Transfer Switch Connection

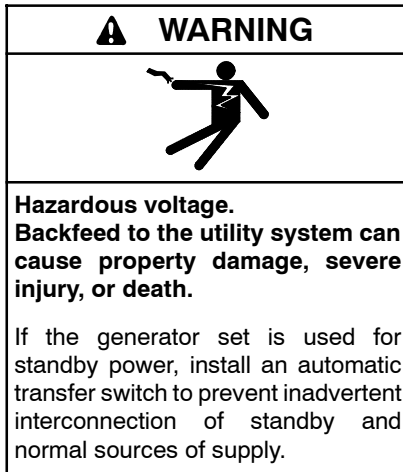

A typical standby system has an automatic transfer switch connected to the generator set output to automatically transfer the electrical load to the generator set if the normal source fails. The normal power source is typically utility power. When normal power returns, the switch transfers the load back to the normal power source and then signals the generator set to stop.

Connect the ATS or remote start/stop switch. Connect the load leads from the generator set to the Emergency source lugs on the ATS. Connect the RBUS or engine start connections as described below. Route low-voltage communication leads through separate conduit from the AC power and load leads. All connections must comply with applicable state and local codes.

Kohler Model RXT Automatic Transfer Switch

The RDC2 controller is designed to control the Kohler Model RXT transfer switch as well as the generator set. Follow the installation instructions to connect the transfer switch interface board to the appropriate terminals on the generator set. The RDC2 controller uses a Kohler-proprietary communication protocol to communicate with the transfer switch.

When connected to a Kohler Model RXT transfer switch, the RDC2 controller provides the following features:

- Monitors and displays utility voltage and frequency.
- Schedule loaded exercises from the RDC2 generator set controller.
- Set the ATS system voltage and frequency.
- Allows calibration of the utility voltage and frequency at the generator set controller.
- Allows adjustment of transfer switch transfer time delays from the generator set controller.

RBUS communication connections for a Kohler® Model RXT transfer switch

One Model RXT transfer switch can be connected to the generator set. See Figure 1-11. Use shielded, twisted-pair cable to connect P10-1 through P10-4 on the transfer switch interface module to the generator set terminal block connections A, B, PWR, and COM. See Section 1.4.8 for communication cable recommendations and maximum cable length.

The Model RXT transfer switch with the combined interface/load management board requires one set of RBUS connections to the generator set. However, the combined board acts as two RBUS modules: one RXT transfer switch and one load management device.

Note: Connections 3 and 4 on the generator set are not used with the Model RXT transfer switch.

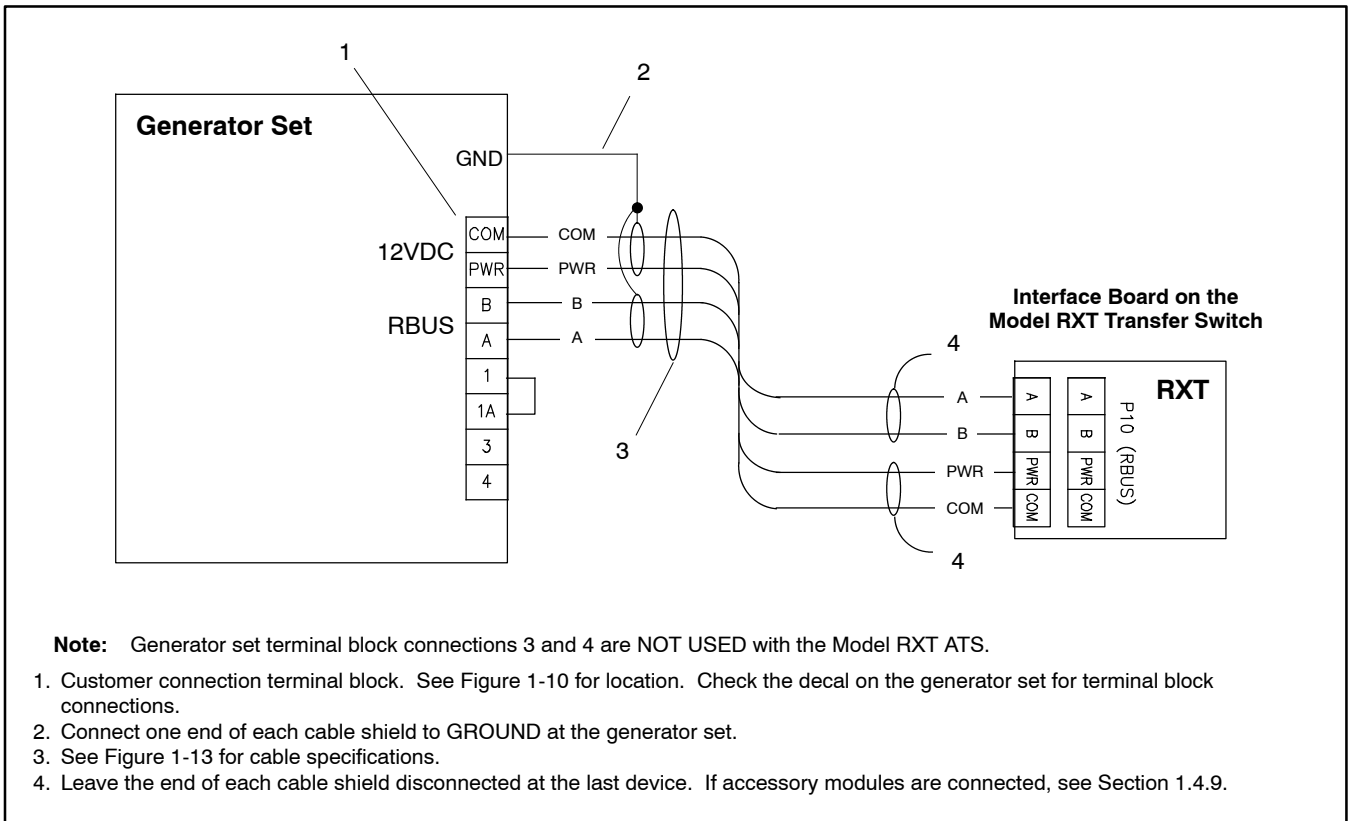

Figure 1-11 Model RXT Transfer Switch Communication Connection to Generator Set Terminal Block

Engine start connection for other transfer switches or a remote start/stop switch

Note: Do not use the Kohler® Model RRT transfer switch with Model RCL generator sets.

Other Kohler transfer switches, including Model RDT and Model K (MPAC™) transfer switches, can be used with the Kohler generator sets covered in this document. These transfer switches contain separate ATS controls that do not communicate with the RDC2 controller.

These transfer switches use a set of contacts to signal the engine/generator to start. When the normal source fails and the generator set is in AUTO mode, the transfer switch contacts close to signal the generator set to start and run. After the normal source returns, the contacts open to signal the generator set to stop.

The engine start terminals are usually located near the transfer switch contactor with an engine start decal identifying the terminals. Use the transfer switch wiring diagrams to identify the engine start terminals prior to making connections.

Connect the transfer switch engine-start contacts or a remote manual engine-start switch to the engine start terminals (3 and 4) on the generator set. Size the wire according to the transfer switch connection and the length of run. Use separate conduit for the DC engine-start leads and the AC generator set load cables and battery charger leads.

See Figure 1-12. Connect the engine start leads from the transfer switch or remote start switch to terminals 3 and 4 on the terminal block. Route the engine start leads through separate conduit from the AC power and load leads.

Close the remote start contacts to start and run the generator set. Open the contacts to signal the generator set to stop. The generator set controller must be in AUTO mode for remote start/stop.

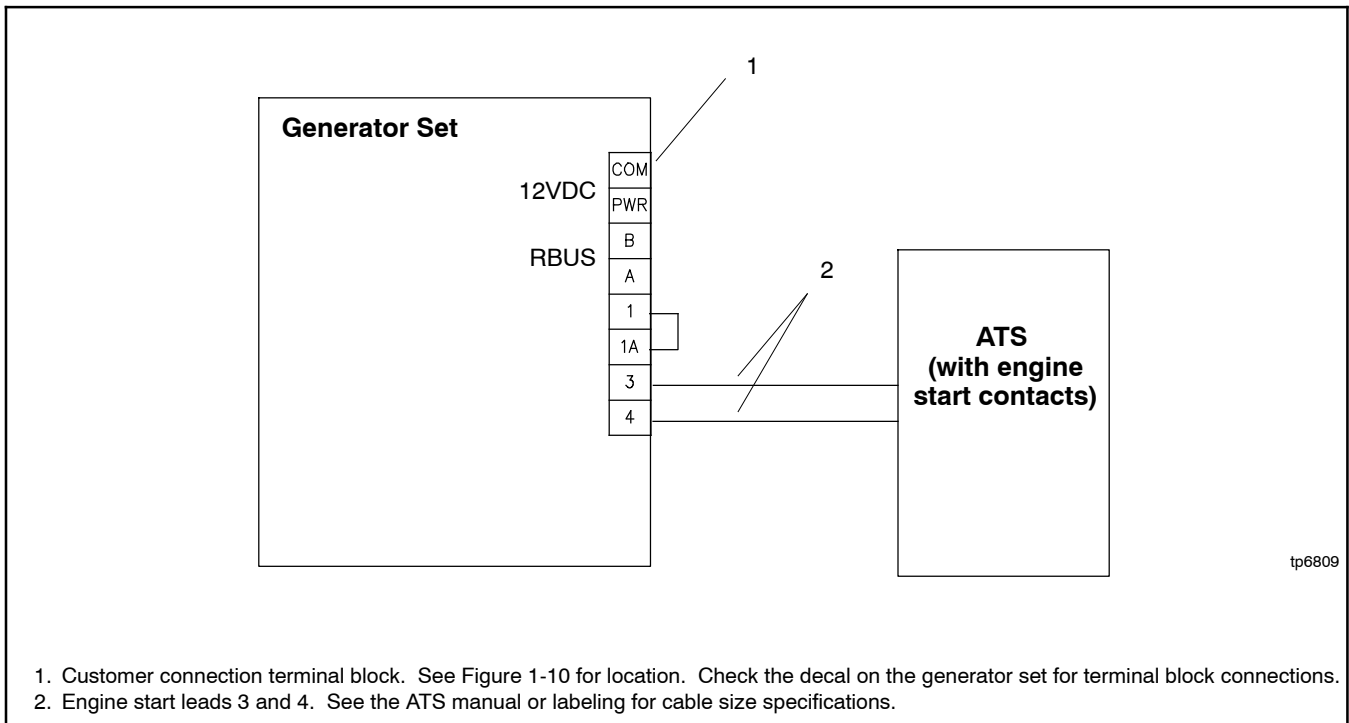

Figure 1-12 Engine Start Connections with Transfer Switch Models other than Model RXT

1.4.8 Communication Cable Specifications

The communication connections for the RXT transfer switch and RBUS accessories include power connections (PWR and COM) and RBUS communication connections (A and B). The cable specifications required for these connections depends on the length of the cable and the number of RBUS devices connected. An RBUS device can be a Model RXT transfer switch, a load management device, or a programmable interface module (PIM).

RBUS Connections A and B

For the RBUS communication connections A and B to the Model RXT transfer switch, optional PIM, and/or optional load shed kit, use 20 AWG shielded, twisted-pair communication cable. Belden #9402 (two-pair) or Belden #8762 (single-pair) or equivalent cable is recommended.

For outdoor installations, including those with buried cables and/or conduit, use outdoor-rated Belden #1075A or equivalent 20 AWG shielded, twisted-pair communication cable.

PWR and COM Connections

The cable used for the PWR and COM connections may need to be larger than the 20AWG communication cable used for A and B. For short runs, use the second pair of leads in the two-pair communication cable. For longer runs, use 12-14 AWG cable as shown in Figure 1-13.

The maximum cable length also depends on the number of optional RBUS modules connected. See Figure 1-13 for the maximum cable lengths for 1, 2, or 3 modules per cable run. Note the shield connections shown in Figure 1-14.

Note: A model RXT transfer switch with combined interface/load management board acts as two RBUS modules: one RXT transfer switch and one load management device.

Note: Power relay modules, if used, are not RBUS modules and do not have RBUS communication connections.

Cable Size for PWR and COM Connections	Indoor or Outdoor Installation	Maximum length per run, meters (ft.)		
		Number of RBUS Modules per Run (RXT ATS, PIM, and/or load management device)		
		1 Module	2 Modules	3 Modules
20 AWG Belden #9402 or equivalent, two-pair	Indoor	61 (200)	31 (100)	21 (67)
20 AWG Belden #1075A or equivalent, two-pair	Outdoor	61 (200)	31 (100)	21 (67)
14 AWG *	—	152 (500)	152 (500)	122 (400)
12 AWG *	—	152 (500)	152 (500)	152 (500)
* Use 12 or 14 AWG cable for PWR and COM connections only. For RBUS connections A and B, always use shielded, twisted pair communication cable.				

Figure 1-13 Total Cable Lengths with Accessory Modules

1.4.9 Accessory Module RBUS Communication Connections

See Figure 1-14 through Figure 1-17 for RBUS communication connection options with up to three accessory modules. Accessory modules can include

one Model RXT transfer switch, one programmable interface module (PIM), and/or one load shed kit.

See Section 1.4.8 for cable size and length specifications.

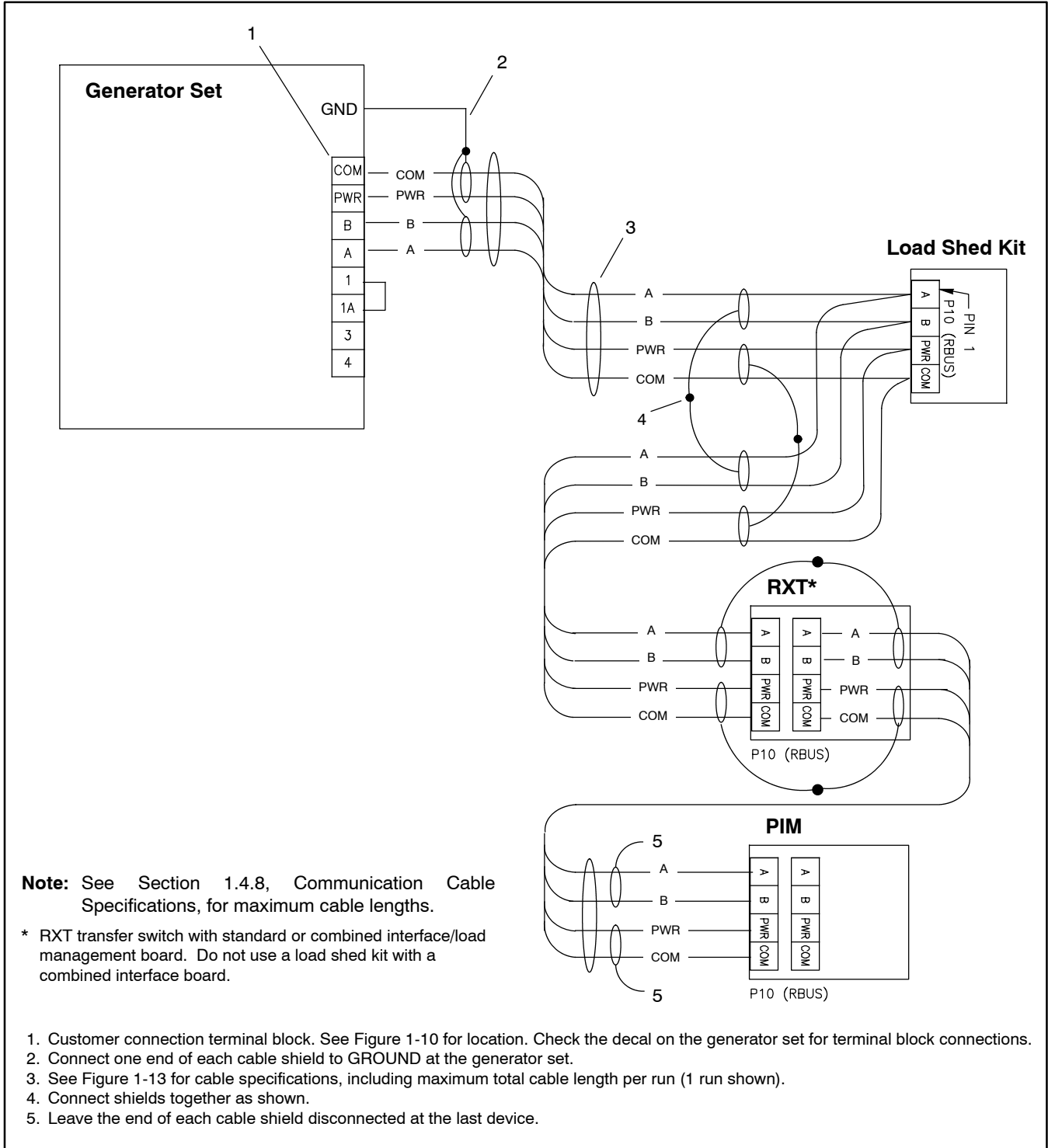

Figure 1-14 Accessory Module Communication Connection Details

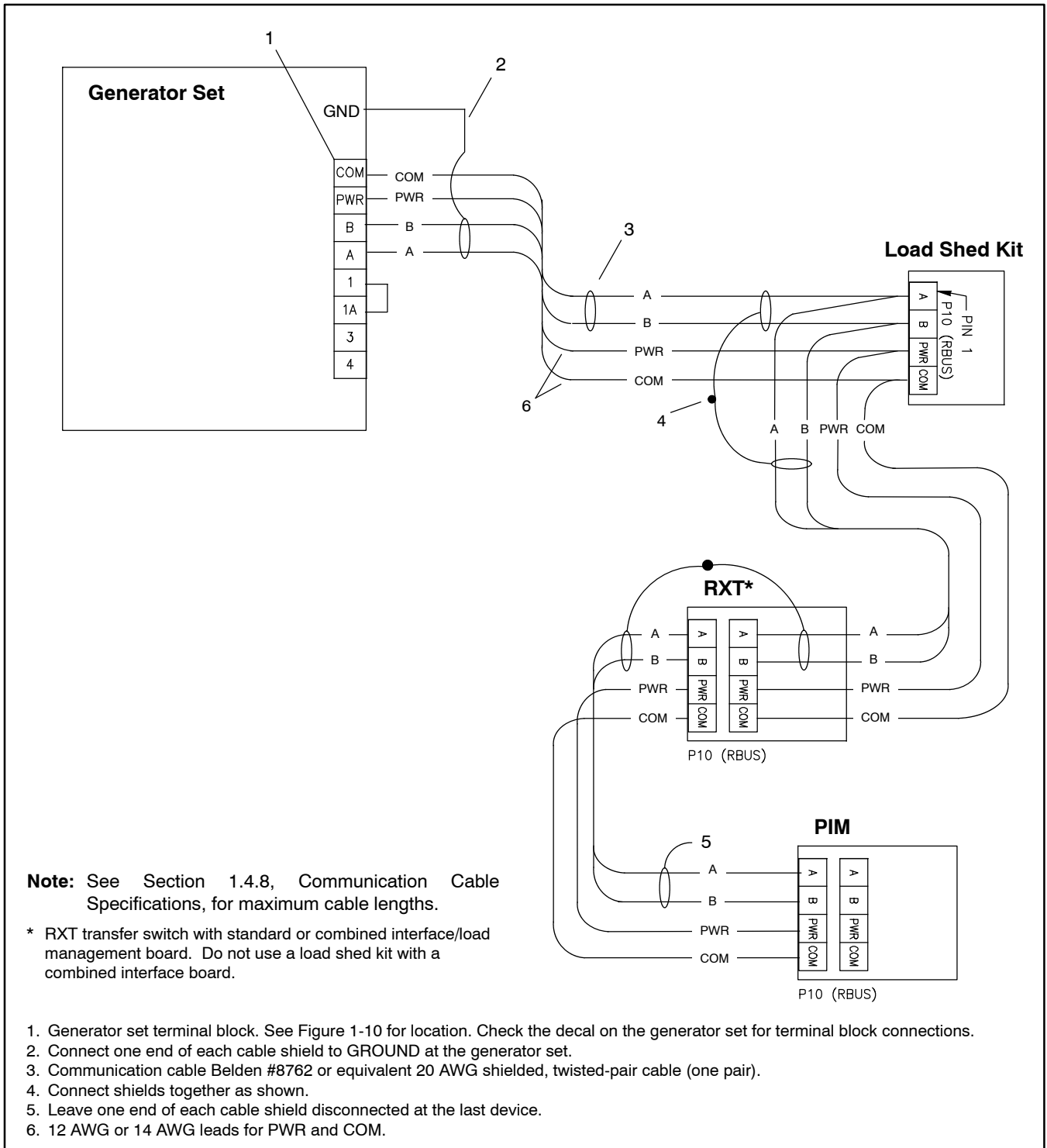

Figure 1-15 Accessory Module Connections with 12-14 AWG Power Leads (one cable run with three modules shown)

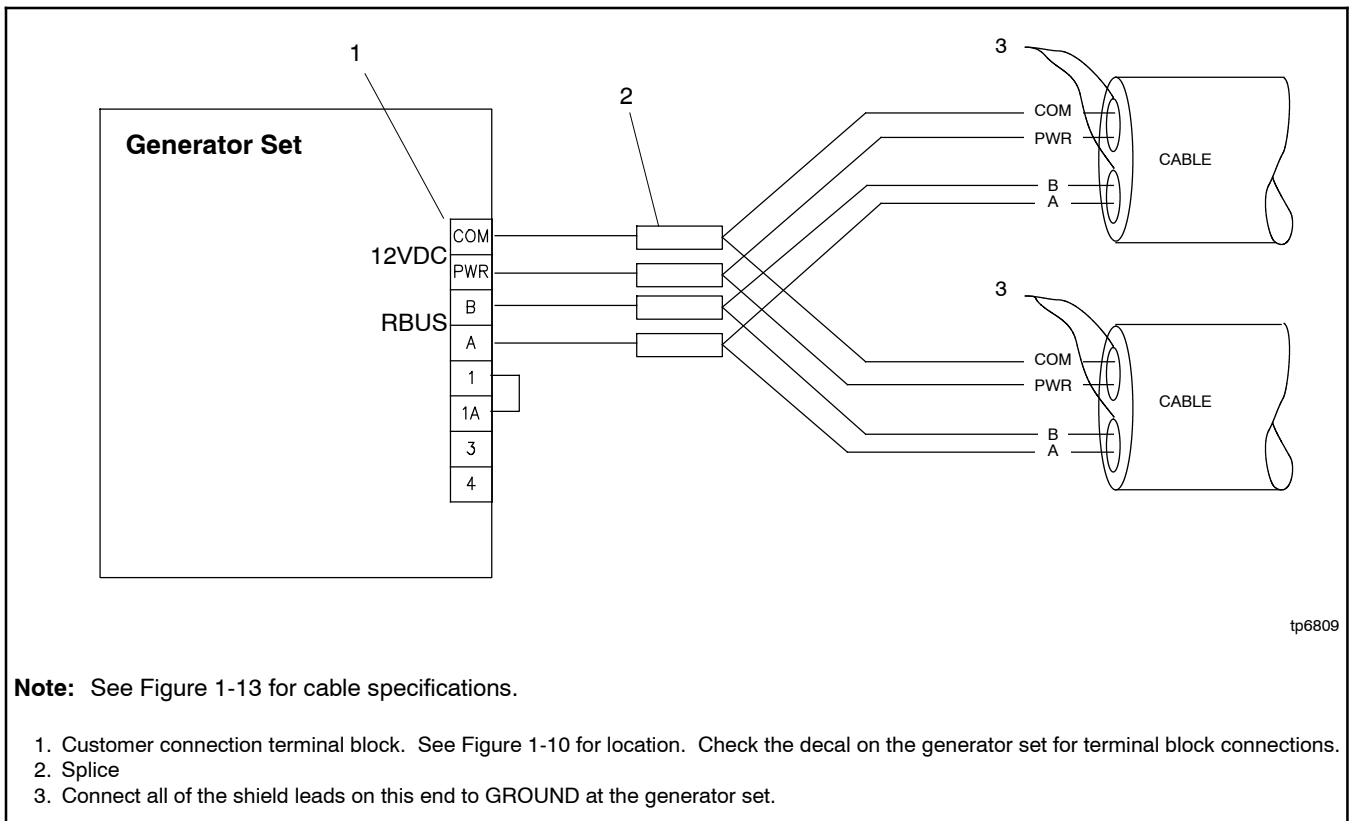

Figure 1-16 Multiple Connections to the Generator Set

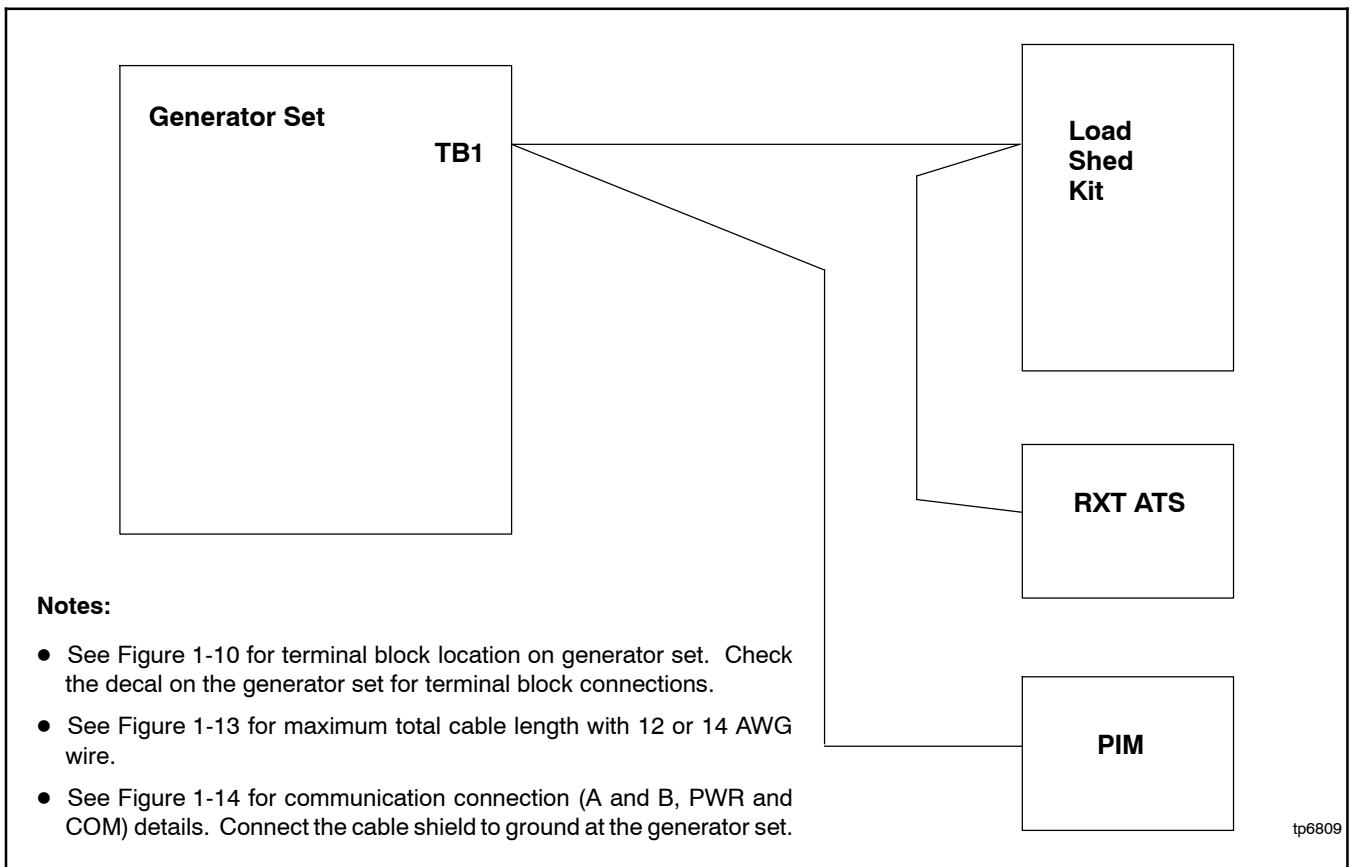

Figure 1-17 Accessory Module Connections (two cable runs with one and two modules shown)

1.4.10 Other Accessories

Install and connect optional accessories. Follow the installation instructions provided with the accessory kits. See Section 2 for information about available accessories.

1.5 Engine Starting Battery

⚠ WARNING



**Sulfuric acid in batteries.
Can cause severe injury or death.**

Wear protective goggles and clothing. Battery acid may cause blindness and burn skin.

⚠ WARNING



**Explosion.
Can cause severe injury or death.
Relays in the battery charger
cause arcs or sparks.**

Locate the battery in a well-ventilated area. Isolate the battery charger from explosive fumes.

Battery gases. Explosion can cause severe injury or death. Battery gases can cause an explosion. Do not smoke or permit flames or sparks to occur near a battery at any time, particularly when it is charging. Do not dispose of a battery in a fire. To prevent burns and sparks that could cause an explosion, avoid touching the battery terminals with tools or other metal objects. Remove all jewelry before servicing the equipment. Discharge static electricity from your body before touching batteries by first touching a grounded metal surface away from the battery. To avoid sparks, do not disturb the battery charger connections while the battery is charging. Always turn the battery charger off before disconnecting the battery connections. Ventilate the compartments containing batteries to prevent accumulation of explosive gases.

Battery short circuits. Explosion can cause severe injury or death. Short circuits can cause bodily injury and/or equipment damage. Disconnect the battery before generator set installation or maintenance. Remove all jewelry before servicing the equipment. Use tools with insulated handles. Remove the negative (-) lead first when disconnecting the battery. Reconnect the negative (-) lead last when reconnecting the battery. Never connect the negative (-) battery cable to the positive (+) connection terminal of the starter solenoid. Do not test the battery condition by shorting the terminals together.

Battery electrolyte is a diluted sulfuric acid. Battery acid can cause severe injury or death. Battery acid can cause blindness and burn skin. Always wear splashproof safety goggles, rubber gloves, and boots when servicing the battery. Do not open a sealed battery or mutilate the battery case. If battery acid splashes in the eyes or on the skin, immediately flush the affected area for 15 minutes with large quantities of clean water. Seek immediate medical aid in the case of eye contact. Never add acid to a battery after placing the battery in service, as this may result in hazardous spattering of battery acid.

Battery acid cleanup. Battery acid can cause severe injury or death. Battery acid is electrically conductive and corrosive. Add 500 g (1 lb.) of bicarbonate of soda (baking soda) to a container with 4 L (1 gal.) of water and mix the neutralizing solution. Pour the neutralizing solution on the spilled battery acid and continue to add the neutralizing solution to the spilled battery acid until all evidence of a chemical reaction (foaming) has ceased. Flush the resulting liquid with water and dry the area.

Use a BCI group 24 size 12-volt battery with a minimum rating of 630 cold cranking amps (CCA) at 0°F.

1. Ensure that the starting battery is fully charged before placing the battery in service.
2. Clean the battery posts and/or adapters if necessary.
3. Install battery post adapters, if needed.
4. See the dimension drawing in Section 4 for the battery rack location. Place the battery on the battery rack on the skid.
5. Connect the red battery cable to the positive (+) battery terminal.
6. Connect the black battery cable to the negative (-) battery terminal.
7. Place the boots over the battery terminals.

When power is applied to the RDC2 controller (that is, when the battery is connected), you will be prompted to set the date and time, and then to set the exerciser. See Section 1.9 and the generator set operation manual for instructions.

If the battery is disconnected for service or replacement, the exercise settings on the RDC2/DC2 controller are lost. Set the exerciser after installing and connecting the battery. See Section 1.9, Set Exerciser.

1.6 Fuel System

WARNING

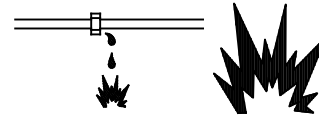

**Explosive fuel vapors.
Can cause severe injury or death.**

Use extreme care when handling, storing, and using fuels.

The fuel system. Explosive fuel vapors can cause severe injury or death. Vaporized fuels are highly explosive. Use extreme care when handling and storing fuels. Store fuels in a well-ventilated area away from spark-producing equipment and out of the reach of children. Never add fuel to the tank while the engine is running because spilled fuel may ignite on contact with hot parts or from sparks. Do not smoke or permit flames or sparks to occur near sources of spilled fuel or fuel vapors. Keep the fuel lines and connections tight and in good condition. Do not replace flexible fuel lines with rigid lines. Use flexible sections to avoid fuel line breakage caused by vibration. Do not operate the generator set in the presence of fuel leaks, fuel accumulation, or sparks. Repair fuel systems before resuming generator set operation.

Gas fuel leaks. Explosive fuel vapors can cause severe injury or death. Fuel leakage can cause an explosion. Check the LPG vapor or natural gas fuel system for leakage by using a soap and water solution with the fuel system test pressurized to 6–8 ounces per square inch (10–14 inches water column). Do not use a soap solution containing either ammonia or chlorine because both prevent bubble formation. A successful test depends on the ability of the solution to bubble.

Explosive fuel vapors can cause severe injury or death. Take additional precautions when using the following fuels:

Propane (LPG)—Adequate ventilation is mandatory. Because propane is heavier than air, install propane gas detectors low in a room. Inspect the detectors per the manufacturer's instructions.

Natural Gas—Adequate ventilation is mandatory. Because natural gas rises, install natural gas detectors high in a room. Inspect the detectors per the manufacturer's instructions.

Gas fuel systems operate on either LP vapor or natural gas. Refer to the generator set specification sheet and Section 1.6.3 for more detailed information on fuel requirements.

Note: The fuel system installation must comply with applicable national, state, and local codes.

1.6.1 Fuel Lines

Gas lines. Never use fuel piping to ground electrical equipment. The gas supplier is responsible for installation, repair, and alteration to gas piping.

Use Schedule 40 black-iron pipe for gas piping. Copper tubing may be used if the fuel does not contain hydrogen sulfide or other ingredients that react chemically with copper.

Line size. Size piping according to the requirements of the equipment. The type of fuel, the distance it must travel from gas meter/tank to fuel shutoff solenoid, and the amount consumed by the engine must be considered when determining fuel line pipe size.

In addition to actual fuel consumption, consider the following pressure loss factors:

- Pipe length
- Other appliances on the same fuel supply
- Number of fittings

Measure the pipe length from the primary gas pressure regulator to the pipe connection on the generator set fuel inlet. Add 2.4 m (8 ft.) to the measured length for each 90 degree elbow. Use the pipe size indicated in Figure 1-18 for the total length of pipe.

Figure 1-18 is based on gas pressures of 3.4 kPa (0.5 psi, 13.8 in. water column) or less and a pressure drop of 0.12 kPa (0.018 psi, 0.5 in. water column) with a 0.60 specific gravity and with a normal amount of restriction from fittings. The LPG flow has been corrected for specific gravity to determine the pipe sizes shown in the table.

Flexible connections. Rigid mount the piping but protect it from vibration. Use flexible connections spanning a minimum of 152 mm (6 in.) between the stationary piping and the engine fuel inlet connection.

Model	Fuel	Maximum Fuel Flow Rate@ Full Load		Nominal Iron Pipe Size, in.							
				Pipe Length, m (ft)							
		cfh	LPG cfh corrected	3.0 (10)	6.1 (20)	12.2 (40)	18.3 (60)	24.4 (80)	30.5 (100)	45.7 (150)	61.0 (200)
38RCL	LPG	224	354	3/4	1	1 1/4	1 1/4	1 1/4	1 1/4	1 1/2	1 1/2
	NG	545	NA	1	1 1/4	1 1/4	1 1/2	1 1/2	1 1/2	2	2
48RCL 48RCLA	LPG	283	447	1	1	1 1/4	1 1/4	1 1/4	1 1/2	1 1/2	2
	NG	699	NA	1 1/4	1 1/4	1 1/2	1 1/2	2	2	2	2 1/2
60RCL	LPG	330	521	1	1 1/4	1 1/4	1 1/4	1 1/2	1 1/2	2	2
	NG	790	NA	1 1/4	1 1/4	1 1/2	1 1/2	2	2	2	2

Figure 1-18 Fuel Pipe Sizes

1.6.2 Gas Regulators

Gas regulators reduce high incoming fuel pressures to lower levels acceptable for engines. See the generator set specification sheet for fuel supply pressure requirements.

Primary gas regulator. The primary regulator reduces the high pressure from a tank or transmission line to the lower pressure required by the secondary regulator on the engine. The fuel supplier provides the primary regulator. The fuel supplier is also responsible for providing sufficient gas pressure to operate the primary regulator.

Secondary gas regulator. The secondary regulator is factory-installed on the generator set engine and controls the inlet pressure to the engine. The models covered by this manual use an electronic pressure regulator. See Section 1.6.4.

Note: The Integrated Electronic Pressure Regulator (IEPR) and air/fuel mixer are specially calibrated emission-control devices. Do not adjust the IEPR or the air/fuel mixer.

1.6.3 Install and Connect Fuel Supply

Note: Read all safety precautions at the beginning of this publication before performing any work on the generator set.

Note: Have the fuel piping and regulator installed by the fuel supplier. The fuel supply installation must comply with NEC and local codes.

1. See the generator set spec sheet for the fuel supply requirements. Add up the fuel requirements for the generator set plus all other gas-fired equipment fueled by the same supply.
2. Check that the primary regulator and gas meter have sufficient capacity for the fuel requirements for the generator set plus all other gas-fired equipment. Have the fuel supplier install a larger gas meter, if necessary.
3. Determine the fuel pipe size as described in Section 1.6.1.
4. Have your fuel supplier install a manual fuel shutoff valve and rigid gas piping. Bring the pipe to within 254 mm (10 in.) of the generator set fuel inlet location.

5. Remove the enclosure door on the service side of the unit.
6. Connect the fuel supply:
 - a. Apply pipe sealant that is approved for fuel connections to the threaded fuel connections.
 - b. Use a section of flexible fuel line to connect the fuel supply to the 1 in. NPT fuel inlet connection on the generator set. See Figure 1-19 or the dimension drawing in Section 4 for the fuel inlet connection location.
 - c. Open the manual fuel valves and leak test all fuel connections using soapy water. If a leak is detected, close the fuel valves, disconnect the lines at the location of the leak, clean the fittings, and apply fresh pipe sealant. Reconnect the lines and recheck for leaks.
7. Verify that the fuel system is set up for the fuel being used (natural gas or LP). See Section 1.6.4.

Note: After the system installation is complete, check for fuel leaks with the generator set running.

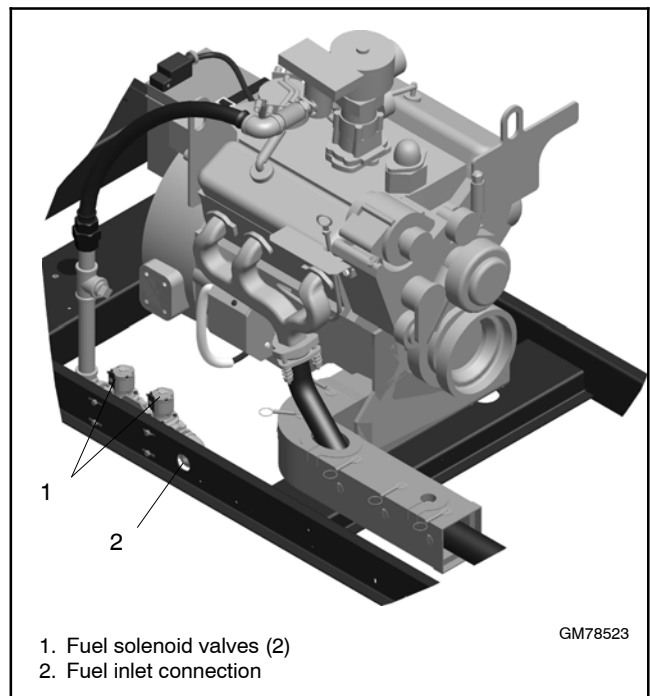

Figure 1-19 Fuel Supply Connection Location (generator set enclosure not shown)

1.6.4 Fuel Conversion Procedures

Note: The Integrated Electronic Pressure Regulator (IEPR) and air/fuel mixer are specially calibrated emission-control devices. Do not adjust the IEPR or the air/fuel mixer.

Check the connections to the fuel solenoid valve to verify that the fuel system is set up for the type of fuel that will be used. See Figure 1-19 for the location of the fuel solenoid valve.

To change the fuel type, change the connection to the fuel solenoid valve as described below and shown in Figure 1-20.

LP Connections:

- Disconnect lead 73A from the fuel valve.
- Connect lead 73B to the fuel valve.
- Connect lead 65 to lead N3 (ground).

Natural Gas Connections:

- Disconnect lead 65 from N3.
- Disconnect lead 73B from the fuel valve.
- Connect lead 73A to the fuel valve.

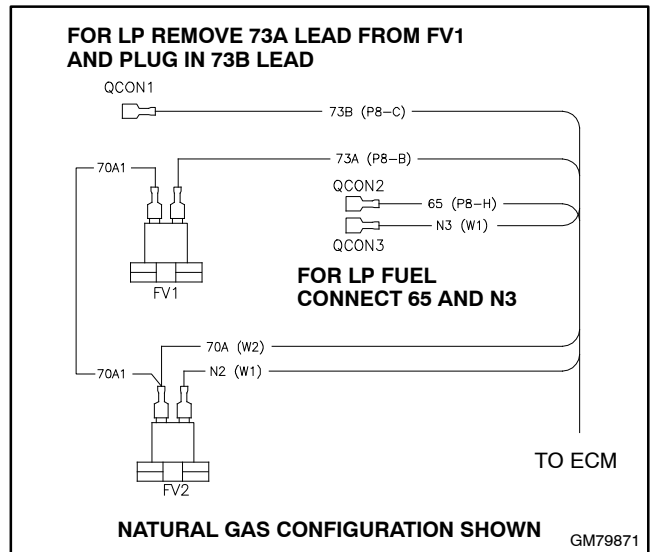
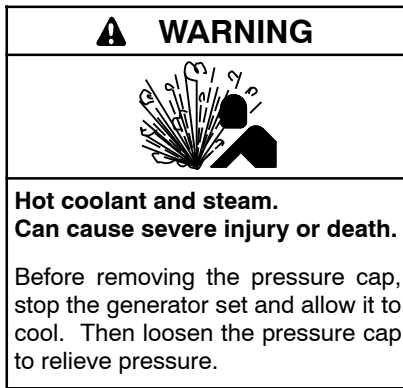

Figure 1-20 Fuel Type Connections

Converting the fuel will change the generator set rating. See the generator set specification sheet for ratings with natural gas and LP. Order a new nameplate with the updated rating and fuel information from an authorized distributor/dealer, if necessary. Provide the following information from the original nameplate:

- Model Number
- Spec Number
- Serial Number
- Fuel (original and new)
- kW
- kVA
- Amps
- Volts
- Hz

1.7 Cooling System



The generator set is equipped with a unit-mounted radiator common cooling system. Add coolant before starting the generator set or energizing the block heater.

The system's major components include two electric fans, a circulating water pump, a radiator, and a thermostat. The pump circulates water through the engine until it reaches operating temperature. Then the engine thermostat opens, allowing water circulation through the radiator. The thermostat restricts water flow as necessary to prevent overcooling. The fans blow air through the radiator across the cooling surface.

Follow the instructions below to fill the cooling system.

1. Close the radiator's coolant drain valve and tighten the hose clamps.

Note: Do not add coolant to a hot engine. Adding coolant to a hot engine can cause the cylinder block or cylinder head to crack. Wait until the engine has cooled.

2. Fill the radiator with the recommended coolant mixture of 50% ethylene glycol-based long-life coolant and 50% clean, softened water to inhibit rust/corrosion and prevent freezing. See Figure 1-21 for coolant capacity and Figure 1-22 for coolant fill location. Do not replace the pressure cap at this time.

Note: A coolant solution of 50% ethylene glycol provides freezing protection to -37°C (-34°F) and overheating protection to 129°C (265°F). A coolant solution with less than 50% ethylene glycol may not provide adequate freezing and overheating protection. A coolant solution with more than 50% ethylene glycol can cause engine or component damage. Do not mix long-life coolant and conventional coolants. Do not use alcohol or methanol antifreeze or mix them with the specified coolant.

3. Check the oil level before operating the engine.

4. Operate the engine with the radiator's pressure cap removed until the thermostat opens and the radiator upper hose becomes hot.
5. Stop the engine and allow it to cool.
6. Add coolant to the radiator to just below the overflow tube on the filler neck. See Figure 1-22.
7. Replace the radiator's pressure cap.
8. Maintain the coolant level in the coolant overflow bottle between the High and Low markings. See Figure 1-22 for the coolant overflow bottle location.

Note: Block Heater Damage. The block heater will fail if the energized heater element is not immersed in coolant. Fill the cooling system before turning on the block heater. Run the engine until it is warm, and refill the radiator to purge the air from the system before energizing the block heater.

Model	Coolant Capacity, L (gal.)	
	Generator Set	With Block Heater
38RCL	15 (4.0)	15.6 (4.2)
48RCL	17 (4.5)	17.6 (4.7)
48RCLA	20.8 (5.5)	21.4 (5.7)
60RCL	20.8 (5.5)	21.4 (5.7)

Figure 1-21 Coolant Capacity

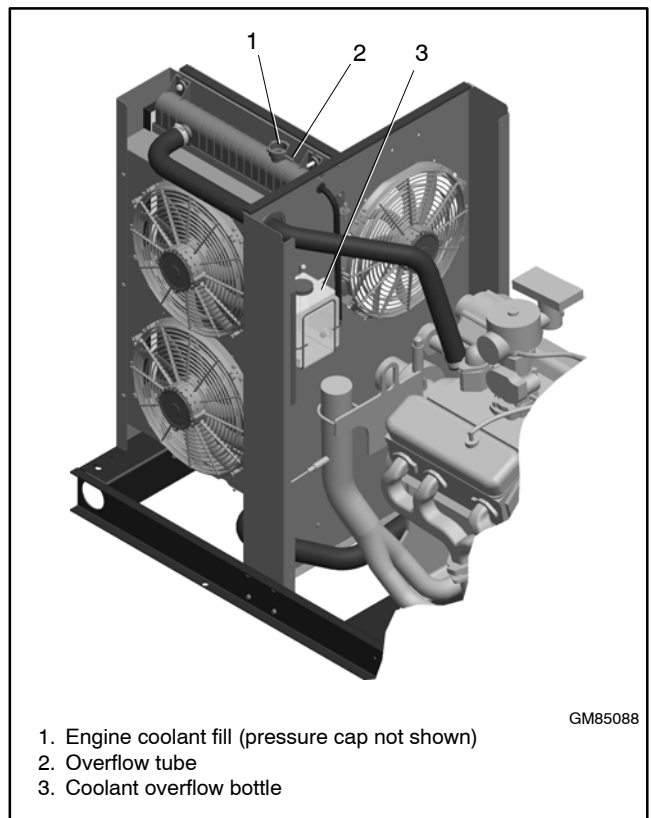

Figure 1-22 Coolant Fill

1.8 Prestart Installation Check

Review the entire installation section. Inspect all wiring and connections to verify that the generator set is ready for operation. Check all items in the following Prestart Checklist.

Prestart Checklist

Air Cleaner. Check that a clean air cleaner element is installed to prevent unfiltered air from entering the engine. See the generator set operation manual for instructions.

Air Inlets. Check for clean and unobstructed air inlets.

Battery. Check for tight battery connections. Consult the battery manufacturer's instructions regarding battery care and maintenance.

Coolant Level. Check the coolant level as described in Section 1.7.

Note: Block Heater Damage. The block heater will fail if the energized heater element is not immersed in coolant. Fill the cooling system before turning on the block heater. Run the engine until it is warm, and refill the radiator to purge the air from the system before energizing the block heater.

Enclosure. Check that all enclosure panels and internal baffling are in place.

Exhaust System. Check for exhaust leaks and blockages. Check the muffler condition.

- Inspect the exhaust system components for cracks, leaks, and corrosion. Check for tight exhaust system connections.
- Check for corroded or broken metal parts and replace them as needed.
- Check that the exhaust outlet is unobstructed.

Oil Level. Maintain the oil level at or near, not over, the full mark on the dipstick.

Operating Area. Check for obstructions that could block the flow of cooling air. Keep the air intake area clean. Do not leave rags, tools, or debris on or near the generator set.

1.9 Set Exerciser

When power is applied to the RDC2 controller (that is, when the battery is connected), you will be prompted to set the date and time, and then to set the exerciser. Set the exerciser to automatically run the generator set on the desired day and time every week or every two weeks.

Figure 1-23 shows the controller screens. The first setting will flash. Press the Up and Down arrow buttons to change the setting. Press Select to save the setting and move on to the next. Repeat until the date, time, and exercise are set and the controller display shows the main menu. See the generator set operation manual for more detailed instructions to set the date and time and set the exerciser.

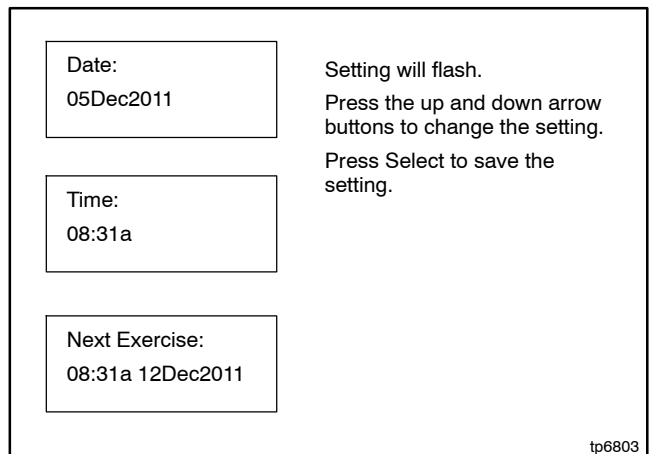
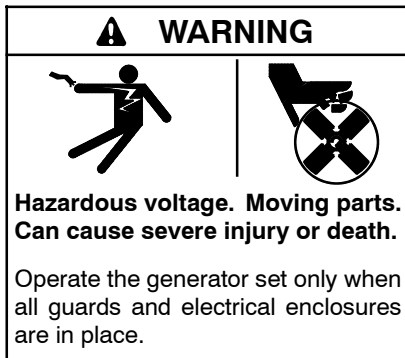

Figure 1-23 Set Date, Time, and Exercise, RDC2 Controller

In order to set a loaded exercise using the RDC2 controller, a Kohler® Model RXT transfer switch must be connected. To set a loaded exercise on a generator set connected to a transfer switch other than a Model RXT, use the transfer switch controller to set the exercise. Refer to the transfer switch operation manual for instructions.

The controller must be in automatic mode for the exerciser to operate as scheduled. Press AUTO to place the generator set controller into automatic mode.

1.10 Operation Tests



1. Verify that all guards are in place. Install the enclosure's end panels and nonservice side door.
2. Check the items in the Prestart Checklist in the generator set operation manual.
3. Set the time and date, and then set the exerciser to run the generator set once a week or every other week to keep the generator set in good operating condition. See the generator set operation manual for instructions to set the date and time and set the exerciser.
4. Press the RUN button on the generator set controller to start the generator set.
5. Use a digital voltmeter (DVM) to check the output voltage from the generator set. If voltage calibration is required, refer to Section 3.5 for instructions.
6. Press OFF to stop the engine. Then press AUTO on the RDC2 controller.
7. Install the enclosure's service-side door. Verify that all enclosure doors and panels are installed. Lock the enclosure doors to prevent unauthorized access.

1.11 OnCue Plus Generator Management System

The OnCue® Plus Generator Management System is included with the RCL generator sets and allows monitoring and control of your generator set from a personal computer, smart phone, or tablet. OnCue Plus can also be configured to send email or text message notifications in the event of a generator set fault. See the documents and manuals provided with the OnCue Plus kit for instructions.

Listed below are the minimum requirements for connecting your generator to the Internet. To use OnCue Plus, you must have:

- “Always-on” Internet service for generator set connection (for example, cable, DSL, or phone line modem connected 24 hours)
- An unused Ethernet port on a switch, router, or modem
- An uninterruptible power supply (UPS) for the modem and router (recommended)
- 5E customer-supplied network cable for connection of the generator set to the customer's Ethernet router (see installation instructions in Section 1.4.6)
- USB cable, male USB A to male mini-B, for updating the controller firmware

For instructions to connect the network cables to the generator set, see Section 1.4.6.

2.1 Introduction

Accessories are available factory-installed and/or shipped loose. Obtain the most current list of accessories from the generator set specification sheet or by contacting an authorized Kohler distributor/ dealer.

Have accessories installed by your local authorized Kohler distributor/dealer or authorized representative. Follow the installation instructions provided with each kit.

Use separate conduit for AC and DC leads to reduce the possibility of electrical interference. Use shielded cable for all analog inputs. Verify that the leads and conduit do not interfere with the operation of the generator set or obstruct the service areas.

Refer to the wiring diagrams in Section 4 for more information regarding generator set electrical connections.

Verify that the accessory installation complies with the National Electrical Code (NEC) and all applicable local and state codes.

The following sections detail a few common accessories and their functions. The instructions provided with the accessory kit supersede these instructions, if different.

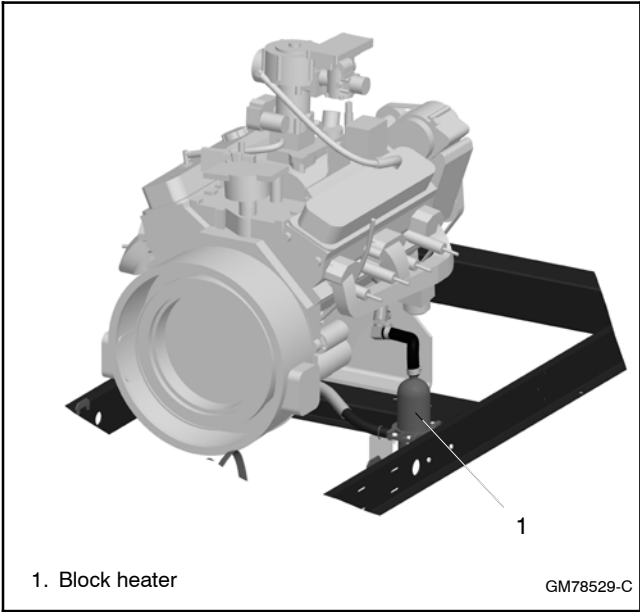

Figure 2-1 Block Heater

2.2 Block Heaters

⚠ DANGER
Hazardous voltage. Will cause severe injury or death.
Disconnect all power sources before opening the enclosure.

⚠ WARNING
Hot engine and exhaust system. Can cause severe injury or death.
Do not work on the generator set until it cools.

Block heaters are available as loose accessories. Use block heaters on standby applications where the generator set is frequently subjected to temperatures below 0°C (32°F).

The generator set engine is equipped with valves that eliminate the need to drain the cooling system before installing the block heater. Refer to the installation instructions provided with the block heater kit.

Connect the block heater to a power source that is energized when the generator set is not running.

Note: Block heater damage. The block heater will fail if the energized heater element is not immersed in coolant. Fill the cooling system before turning on the block heater. Run the engine until it is warm and refill the radiator to purge the air from the system before energizing the block heater.

2.3 Programmable Interface Module (PIM)

The optional Programmable Interface Module (PIM) provides two programmable inputs and six dry contact outputs, four of which are programmable. The PIM with enclosure is shown in Figure 2-2. See TT-1584 for PIM installation and connection instructions.

The PIM is mounted in a NEMA 3R aluminum enclosure, which can be mounted indoors or outdoors. See Section 1.4.9 and the installation instructions provided with the PIM for the maximum recommended cable lengths and detailed installation instructions.

2.3.1 PIM to Generator Set Connections

The PIM communicates with the RDC2 generator set controller. Connect the PIM module to the generator set as shown in Section 1.4.9.

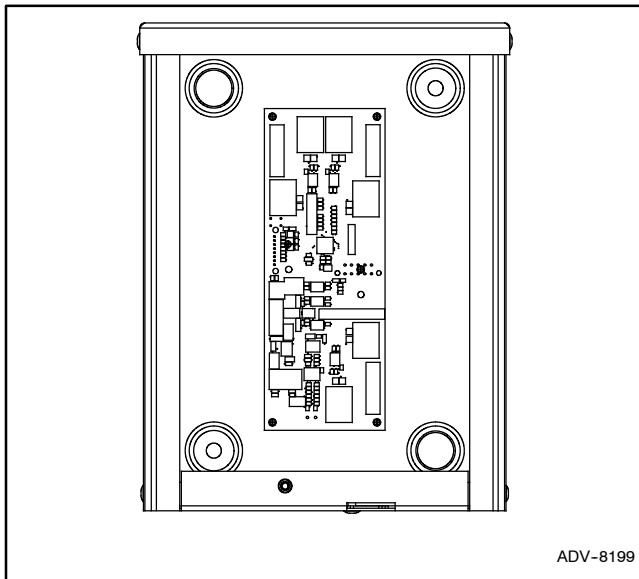

Figure 2-2 Programmable Interface Module (PIM) (covered removed for illustration)

2.3.2 PIM Inputs and Outputs

Connect customer-supplied equipment to the PIM as instructed in TT-1584.

Factory-default settings for the outputs are shown in Figure 2-3. The outputs are controlled by the RDC2 controller. The run output is activated when the generator set is running. The common fault output is activated on a fault.

Use a personal computer running Kohler® OnCue® Plus or SiteTech™ software to assign functions to the other inputs and outputs, and/or change the settings for factory-set inputs and outputs. Verify that the input and output assignments match the connections to the PIM terminal strip.

Outputs 3 through 6 can also be controlled remotely using the OnCue® Plus program. If an output is activated or deactivated through OnCue Plus, it is no longer controlled by the RDC2 controller. See the OnCue Plus manuals for instructions.

PIM Connection	Factory Default Setting
Input 1	None
Input 2	None
Output 1 (Relay 1)	Run
Output 2 (Relay 2)	Common Fault
Output 3 (Relay 3)	Low Battery Voltage (programmable)
Output 4 (Relay 4)	Not in Auto (programmable)
Output 5 (Relay 5)	Cooldown (programmable)
Output 6 (Relay 6)	Normal Source Failure (programmable)

Figure 2-3 PIM Factory Settings

2.4 Load Management

Two optional load management devices are available for use with single-phase generator sets and a model RXT or RDT transfer switch:

- The optional Load Shed Kit mounts inside a model RDT or RXT transfer switch. Figure 2-4 shows the load shed assembly.
- The combined interface/load management board is available for the Model RXT transfer switch.

The devices provide an automatic load management system to comply with Section 702.5 of NEC 2008.

Note: The load management devices are only compatible with single-phase generator sets.

With a load management system, less critical appliances can be powered by the generator set when the more important appliances are not running, allowing the use of a smaller generator set than would be needed to run all of the building's electrical equipment at the same time.

The load management device automatically manages up to six residential loads.

- Two relays are included to control two independent heating, ventilation, and air conditioning (HVAC) loads.
- Up to four power relay modules can be connected through normally open relay contacts on the circuit board. Power relay modules are available separately. See Figure 2-5.

The load management device receives commands from the RDC2 or DC2 generator controller and energizes or de-energizes the appropriate load relays to add or shed non-critical loads according to their priority.

Note: Connect only non-essential loads to the load shed kit.

An adequate electrical supply is required for operation of the customer-supplied power relays connected to the load shed kit. Check the electrical requirements of the customer-provided equipment prior to installation to determine the wire size and circuit protection required. The installer is responsible for ensuring that the power system installation complies with all applicable state and local codes.

For detailed installation and connection instructions, see TT-1609, provided with the load shed kit, or TP-6807, Operation/Installation Manual for the Model RXT transfer switch with combined interface/load management board.

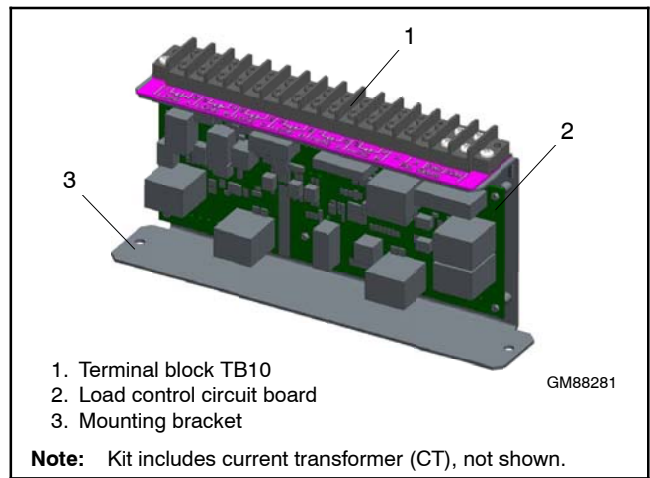

Figure 2-4 Load Shed Assembly GM88281-1 (mounts inside the transfer switch enclosure)

2.4.1 Power Relay Module

The power relay module kit contains one 50 amp relay with connecting lugs in a NEMA type 3R enclosure. Connect up to four (4) power relay modules to the load management devices listed above.

The power relay modules can be mounted indoors or outdoors. Two (2) 120 VAC loads (shed simultaneously) or a single 240 VAC load can be wired to each relay.

For detailed installation and connection instructions, see TT-1646, provided with the power relay module kit.



Figure 2-5 Power Relay Module

Notes

Section 3 Generator Reconnection

3.1 Voltage Reconnection

The reconnection procedure explains voltage reconnections only. Do not attempt to change the frequency (e.g. from 60 Hz to 50 Hz) in the field.

The following instructions explain the reconnection of 12-lead generator sets. In all cases, follow the National Electrical Code (NEC) guidelines.

Reconnect the stator leads of the generator set if a different output phase or voltage is desired. Refer to the following procedure and the connection schematics. Follow all safety precautions at the front of this manual and in the text while performing this procedure.

Note: Order voltage reconnection decal 246242 from an authorized service distributor/dealer and affix decal to generator set after reconnecting to a voltage different than the nameplate.

⚠ WARNING

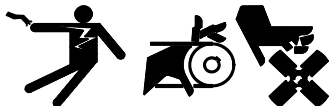

Accidental starting. Can cause severe injury or death.

Disconnect the battery cables before working on the generator set. Remove the negative (-) lead first when disconnecting the battery. Reconnect the negative (-) lead last when reconnecting the battery.

Disabling the generator set. Accidental starting can cause severe injury or death. Before working on the generator set or equipment connected to the set, disable the generator set as follows: (1) Move the generator set master switch to the OFF position. (2) Disconnect the power to the battery charger. (3) Remove the battery cables, negative (-) lead first. Reconnect the negative (-) lead last when reconnecting the battery. Follow these precautions to prevent starting of the generator set by an automatic transfer switch, remote start/stop switch, or engine start command from a remote computer.

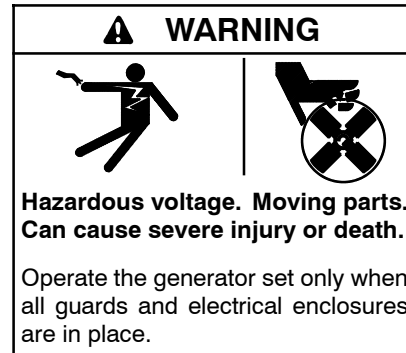

Grounding electrical equipment. Hazardous voltage can cause severe injury or death. Electrocutation is possible whenever electricity is present. Ensure you comply with all applicable codes and standards. Electrically ground the generator set, transfer switch, and related equipment and electrical circuits. Turn off the main circuit breakers of all power sources before servicing the equipment. Never contact electrical leads or appliances when standing in water or on wet ground because these conditions increase the risk of electrocution.

Short circuits. Hazardous voltage/current can cause severe injury or death. Short circuits can cause bodily injury and/or equipment damage. Do not contact electrical connections with tools or jewelry while making adjustments or repairs. Remove all jewelry before servicing the equipment.

3.2 Four-Lead (Single-Phase) Generator Sets

Figure 3-1 shows the factory connection for the single-phase 120/240 V 60 Hz generator set. Four-lead, single-phase models are not reconnectable.

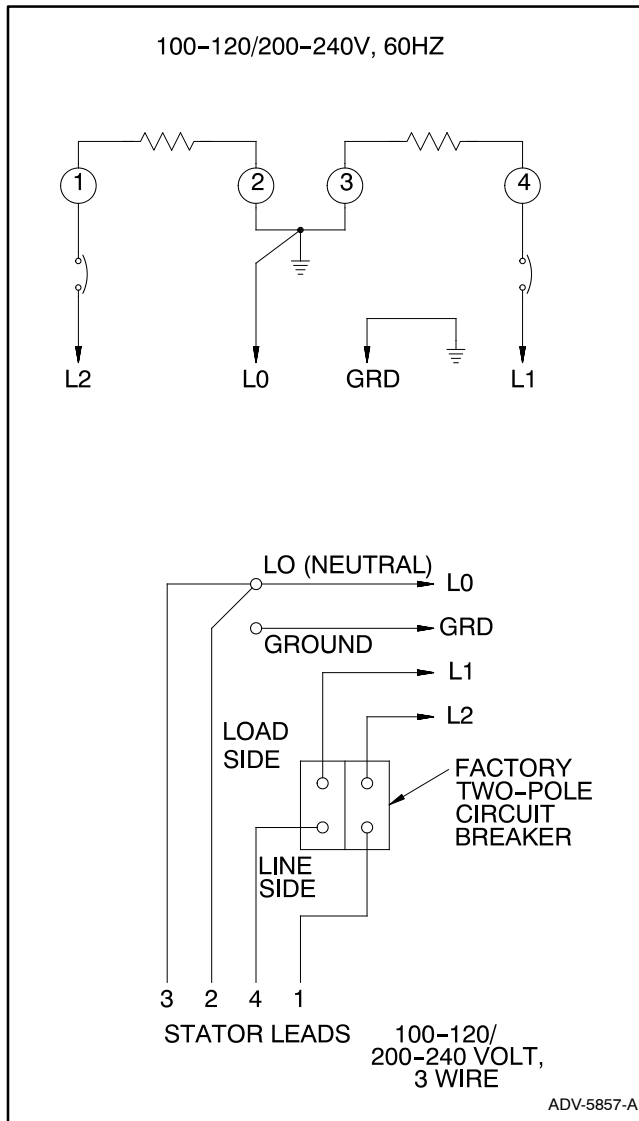

Figure 3-1 Single-Phase Factory Connection, 120/240 V 60 Hz

3.3 12-Lead (Three-Phase) Generator Sets

Three-phase, 12-lead generator sets are reconnectable to the voltages and phases shown on the generator set specification sheet. See Figure 3-2 or Figure 3-3 and use the following procedure to reconnect the generator to the desired voltage configuration, change the system voltage setting, and adjust the output voltage.

Note: The current transformers (CTs) shown in Figure 3-3 are not used on Model 48RCL, 48RCLA, or 60RCL generator sets.

Note: Equipment damage. Verify that the voltage ratings of the transfer switch, line circuit breakers, and other accessories match the selected line voltage.

Reconnection Procedure

1. Press the OFF button on the RDC2 controller.
2. Disconnect engine starting battery, negative (-) lead first.
3. Disconnect utility power to the generator set.
4. Select desired voltage connection. See Figure 3-2 for the 38RCL or Figure 3-3 for the 48RCL, 48RCLA, and 60RCL. Connect the leads according to the diagram for desired phase and voltage.
5. Reconnect generator set engine starting battery, negative (-) lead last.
6. Follow the instructions in Section 3.4 to enter the RDC2 Genset System menu. Check the system voltage, frequency, and phase settings, and change them if necessary.
7. Connect a digital multimeter (DVM) to the generator set output.
8. Press RUN to start the generator set.
9. Use a voltmeter to check for the correct voltage output from the generator set. Follow the instructions in Section 3.5 to calibrate the voltage on the RDC2 controller, if necessary.
10. Press OFF to stop the generator set.
11. Reconnect utility power to the generator set.
12. Press AUTO to place the generator set in automatic mode.

12 LEAD ALTERNATOR, 4 WIRE, LOW WYE

60 HZ: 120/208V
60 HZ: 127/220V

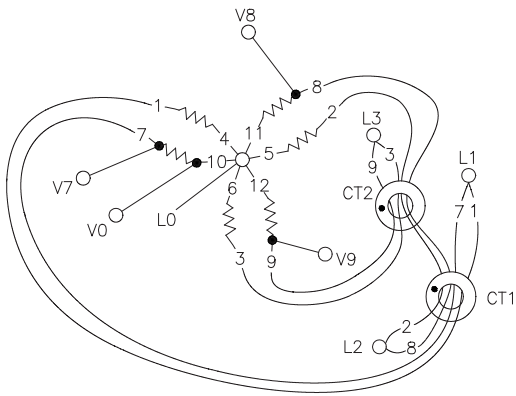

12 LEAD ALTERNATOR, 4 WIRE, HI WYE

60 HZ: 277/480V 50 HZ: 220/380V
50 HZ: 230/400V 50 HZ: 240/416V

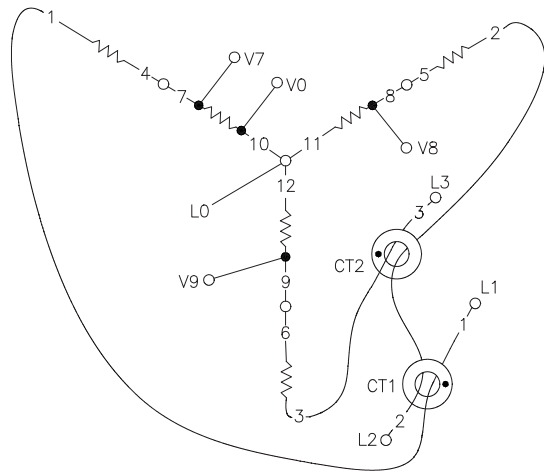

12 LEAD ALTERNATOR, 4 WIRE, DELTA

60 HZ: 120/240V

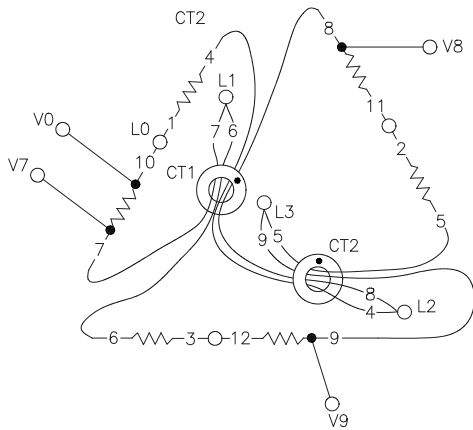

NOTES:
CURRENT TRANSFORMER DOT OR "H1" TOWARD GENERATOR.

PHASE ROTATION

A	B	C
L1	L2	L3

ADV-5875E-P

Figure 3-2 12-Lead Generator Reconnection, 38RCL

12 LEAD ALTERNATOR, 3 WIRE, SINGLE PHASE

60 HZ: 100/200V
 60 HZ: 120/240V
 50 HZ: 100/200V
 50 HZ: 110/220V

SOME SETS NOT RATED FOR SINGLE PHASE - SEE MANUALS

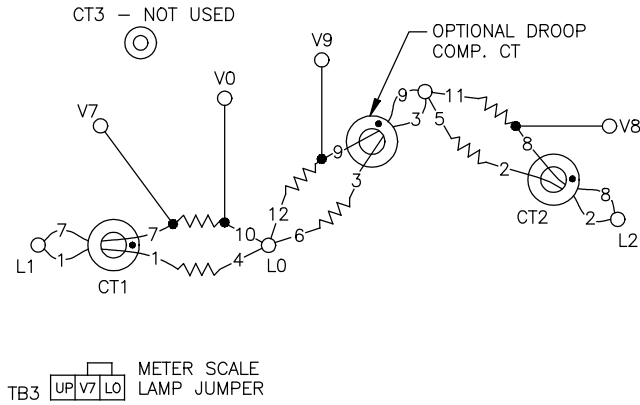

12 LEAD ALTERNATOR, 4 WIRE, DELTA

60 HZ: 120/240V
 50 HZ: 110/220V

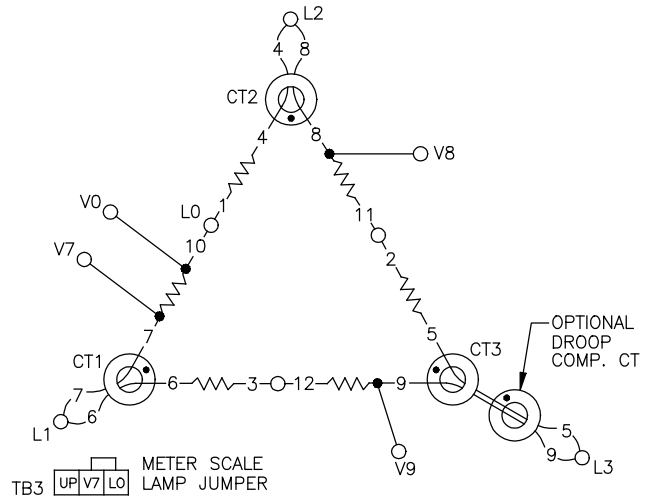

12 LEAD ALTERNATOR, 4 WIRE, LOW WYE

60 HZ: 120/208V 50 HZ: 110/190V
 60 HZ: 127/220V 50 HZ: 115/200V
 60 HZ: 139/240V 50 HZ: 120/208V

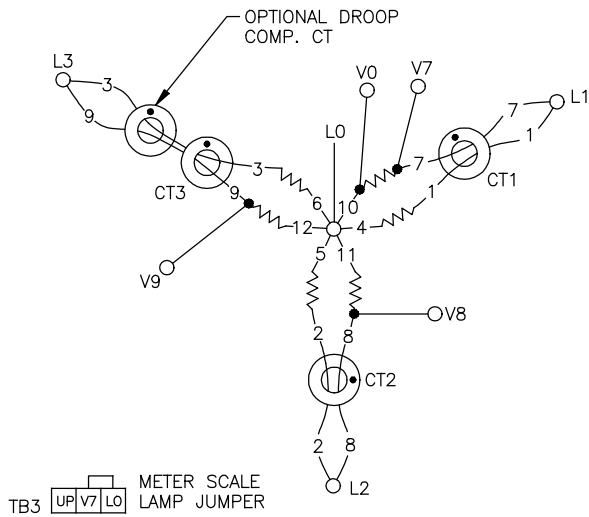

12 LEAD ALTERNATOR, 4 WIRE, HI WYE

60 HZ: 220/380V 50 HZ: 220/380V
 60 HZ: 240/416V 50 HZ: 230/400V
 60 HZ: 277/480V 50 HZ: 240/416V

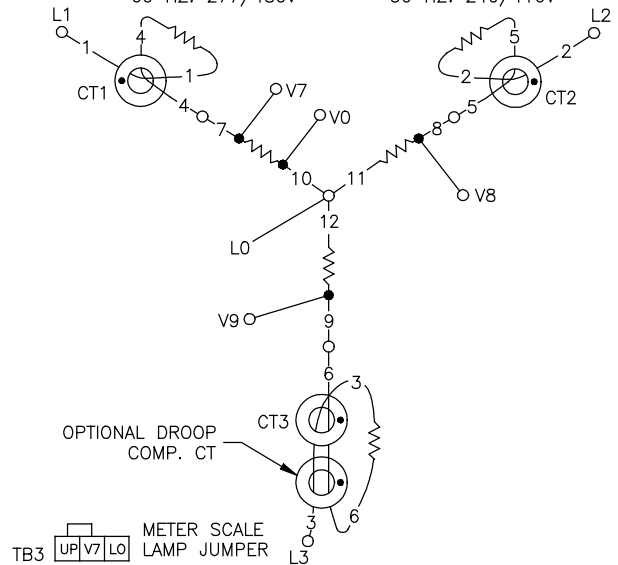

Note: The current transformers (CTs) shown above are not used on Model 48RCL, 48RCLA, or 60RCL generator sets equipped with the RDC2 controller.

PHASE ROTATION

A	B	C
L1	L2	L3

ADV-5875B-J

Figure 3-3 12-Lead Generator Reconnection, 48RCL, 48RCLA, and 60RCL

3.4 Changing System Settings

The RDC2 controller's keypad and display allow the installer to check and change the generator system settings, if necessary. The system settings for each generator model are set at the factory and should not normally require changes. Check the genset system settings and change them, if necessary, after generator reconnection or controller replacement.

The following procedure explains how to change the system settings. The procedure is also illustrated in Figure 3-6.

Procedure to Change System Settings

1. Press the Select button to enter the main menu. See Figure 3-4 and Figure 3-5. The Overview screen will be displayed.
2. Press the down arrow button to navigate to the Genset System menu. See Figure 3-5.
3. Press the Select button to enter the Genset System menu. See Figure 3-6.
4. Press the down arrow button to step through the generator set system settings to the setting that you wish to change.
5. When the setting is displayed (for example, System Voltage), press the select button. The value will flash.
6. Press the up or down arrow buttons to increase or decrease the setting.
7. When the desired setting is shown, press Select. The value stops flashing and the new setting is saved.

8. Press the down arrow to step to the next setting.
9. To exit, press the down arrow button until Return is displayed. Press the Select button to exit the menu.
10. Press the AUTO or OFF button to exit the main menu.

Note: If no buttons are pushed, the controller exits the menus and returns to the generator set status display after 5 minutes.

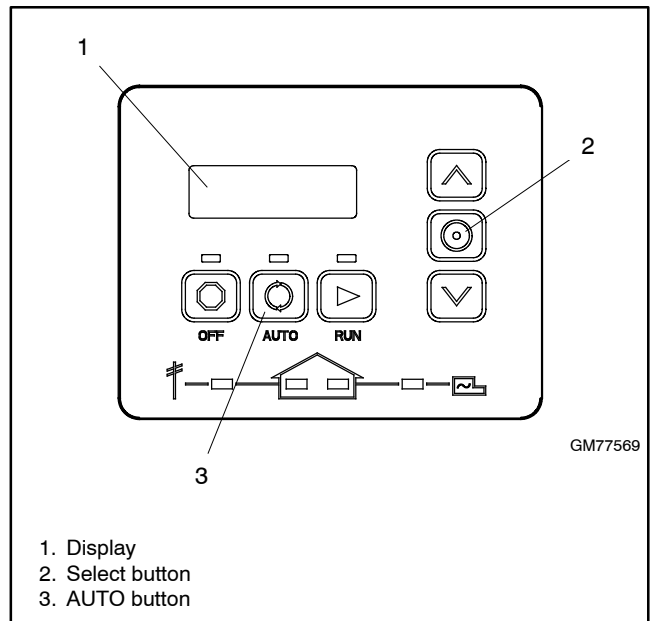

Figure 3-4 RDC2 Controller User Interface

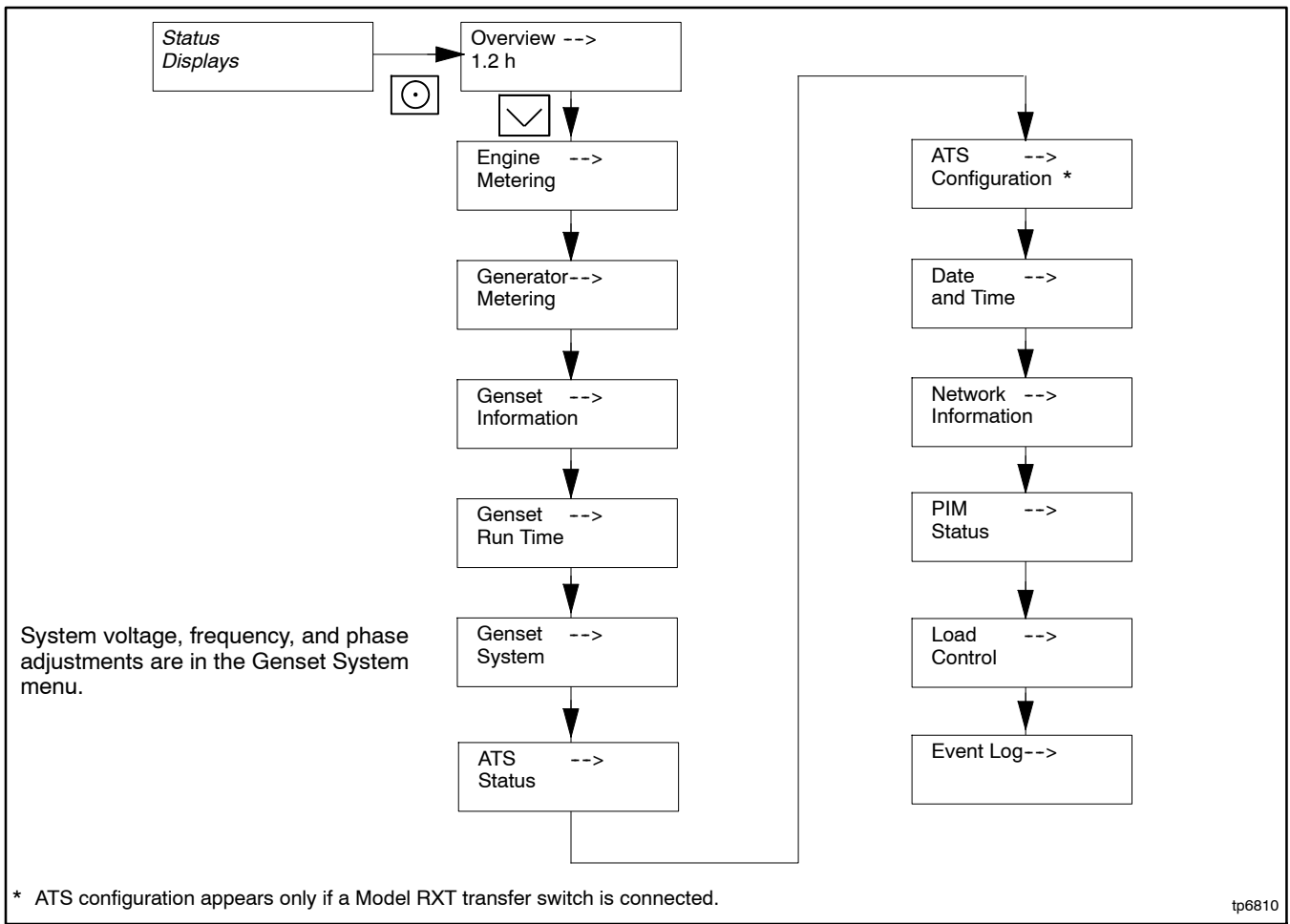



Figure 3-5 RDC2 Main Menu

Changing System Settings on the RDC2 Controller

1. Press the Select button to enter the main menu.

Press:  **Display:** Overview -->
1.2 h

2. Press the down arrow button to navigate to the Genset System menu. See Figure 3-5.

Press:  **Display:** Genset -->
System

3. Press the Select button to enter the genset system menu.

Press:  **Display:** System Voltage:
240 V

4. Press the down arrow button, if necessary, to step to the setting that you want to change.

5. When the setting is displayed (for example, System Voltage), press the select button. The value will flash.

Press:  **Display:** System Voltage
240 V

6. Press the up or down arrow buttons to increase or decrease the setting.

Press:  **Display:** System Voltage
220 V

7. When the desired setting is shown, press Select. The value stops flashing.

Press:  **Display:** System Voltage
220 V

8. Press the down arrow to step to the next setting.

Press:  **Display:** System Freq:
60 Hz

9. To exit, press the down arrow button until Return is displayed.

Press:  **Display:** Return -->

10. Press the Select button to exit the menu.

Press:  **Display:** Overview -->
1.2 h

11. Press Auto to signal the controller to exit the menus and return to the generator set status display.

Press:  **Display:** Genset State
Standby

AUTO

Note: If no buttons are pushed, the controller returns to the status display after 5 minutes.

Figure 3-6 Changing Genset System Settings

3.5 Voltage Calibration

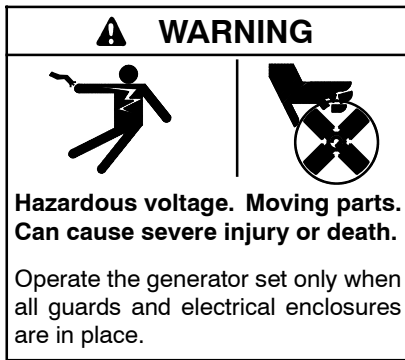

Testing live electrical circuits. Hazardous voltage or current can cause severe injury or death. Have trained and qualified personnel take diagnostic measurements of live circuits. Use adequately rated test equipment with electrically insulated probes and follow the instructions of the test equipment manufacturer when performing voltage tests. Observe the following precautions when performing voltage tests: (1) Remove all jewelry. (2) Stand on a dry, approved electrically insulated mat. (3) Do not touch the enclosure or components inside the enclosure. (4) Be prepared for the system to operate automatically.
(600 volts and under)

Short circuits. Hazardous voltage/current can cause severe injury or death. Short circuits can cause bodily injury and/or equipment damage. Do not contact electrical connections with tools or jewelry while making adjustments or repairs. Remove all jewelry before servicing the equipment.

Correct voltage calibration is necessary for proper generator set operation. Check the voltage calibration after controller replacement or generator set reconnection, and adjust if necessary.

The RDC2 controller can be calibrated using the controller keypad and menus, or using a personal computer with Kohler® SiteTech™ software.

3.5.1 Calibration using the RDC2 Controller Keypad and Menu

The controller's voltage calibration can be adjusted using the controller keypad. See Figure 3-7 and follow the procedure below.

Note: A digital voltmeter is required for these adjustments.

1. With the generator set off, connect a digital multimeter to measure output voltage across L1 and L2. Set the meter to measure AC volts.
2. Start the generator set by pressing the RUN button on the RDC2 controller.
3. On the RDC2 controller, press the Select button and then use the arrow buttons to navigate to the Generator Metering menu on the RDC2 controller.
4. Press the Select button to display Volts L1-L2. Compare the number displayed with the voltmeter reading.
5. If the correct voltage is not displayed, follow these steps to adjust it:
 - a. Press the Select button. The voltage will flash.
 - b. Press the up or down arrow button to adjust the voltage to match the voltmeter reading.
 - c. Press Select to save the voltage setting. The voltage stops flashing.
 - d. Wait for the voltmeter reading to stabilize. This may take 30 to 60 seconds.
6. For three-phase models, press the Down arrow button and repeat the calibration procedure for voltage across L2-L3 and L3-L1.
7. Use the arrow buttons to step down to the Return screen. Press Select to exit the Generator Metering menu.
8. Press OFF to stop the generator set.

Reset Calibration

Pressing the select button when "Reset Calibration? Yes" is displayed will discard the changes and reset the calibration to the original settings. See Figure 3-7.

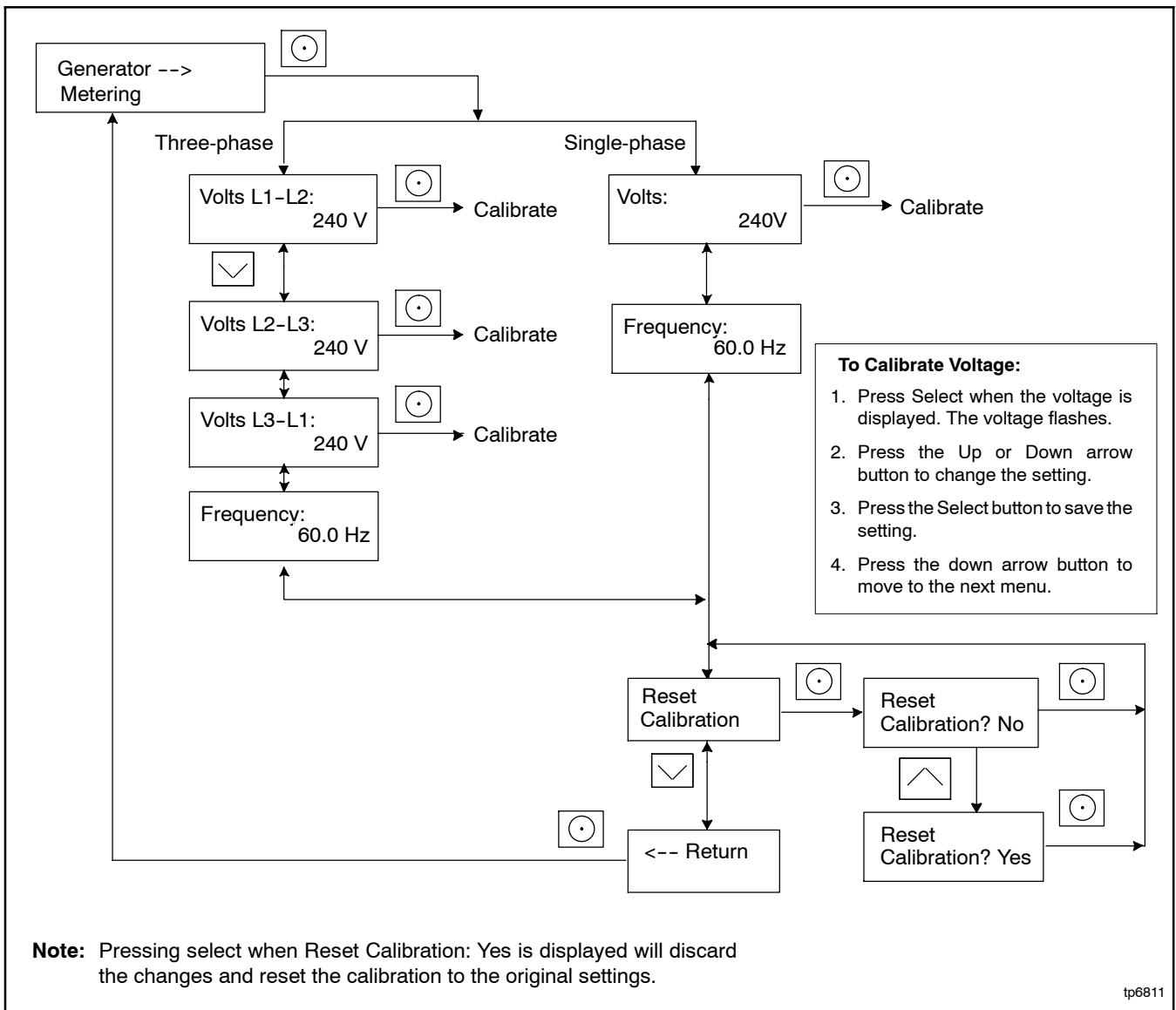

Figure 3-7 Voltage Calibration

3.5.2 Calibration Using SiteTech

Note: Read all safety precautions at the beginning of Section 3.5 before performing the calibration procedure.

Voltage calibration factors can be adjusted using SiteTech software to calibrate the RDC2 controller. Connect a personal computer (laptop) to the controller using a USB cable and follow this procedure to use Kohler® SiteTech™ software to calibrate the controller.

The voltage calibration factors are located in the Genset Calibration group in SiteTech™. Find the parameter labelled Genset Calibration Factor Voltage, L1-L2. See Figure 3-9.

Note: A digital voltmeter is required for these adjustments.

1. With the generator set off, connect a digital multimeter to measure output voltage across L1 and L2. Set the meter to measure AC volts.
2. Start the generator set by pressing the RUN button on the RDC2 controller.
3. Compare the voltage reading on the digital voltmeter to the voltage displayed by the controller.
4. If the voltage displayed on the controller does not match the measured voltage, use the equation in Figure 3-8 to calculate a new value for Genset Calibration Factor Voltage, L1-L2.
5. Type the new value for Genset Calibration Factor Voltage, L1-L2 into SiteTech and click on Apply Changes. See Figure 3-9.
6. Allow a few seconds for the controller to adjust to the new factor and then compare the voltmeter reading with the voltage displayed on the controller.

7. If the voltage readings do not match, check your calculations. Check the calibration factor and both voltage readings again. Repeat the procedure using the new values, if necessary.

Note: If you would like to simplify the calculation, set the calibration factor to 1.0000 and then repeat the calibration procedure from step 3.

8. Repeat the procedure for voltage across L2-L3 and L3-L1, if necessary. (Three-phase only.)
9. Press OFF to stop the generator set.

$$(V_{\text{meter}} \div V_{\text{control}}) \times F_{\text{old}} = F_{\text{new}}$$

V_{meter} = Voltmeter reading

V_{control} = Voltage displayed on controller

F_{old} = Genset Calibration Factor Voltage, L1-L2, from SiteTech before calibration

F_{new} = New value to enter for Genset Calibration Factor Voltage, L1-L2, in SiteTech

Example:

Voltmeter reading: 241.2

Controller display: 240

Old calibration factor (from SiteTech): 1.0063

New calibration factor:

$$(241.2 \div 240) \times 1.0063 = \mathbf{1.0113}$$

Figure 3-8 Voltage Calibration Factor

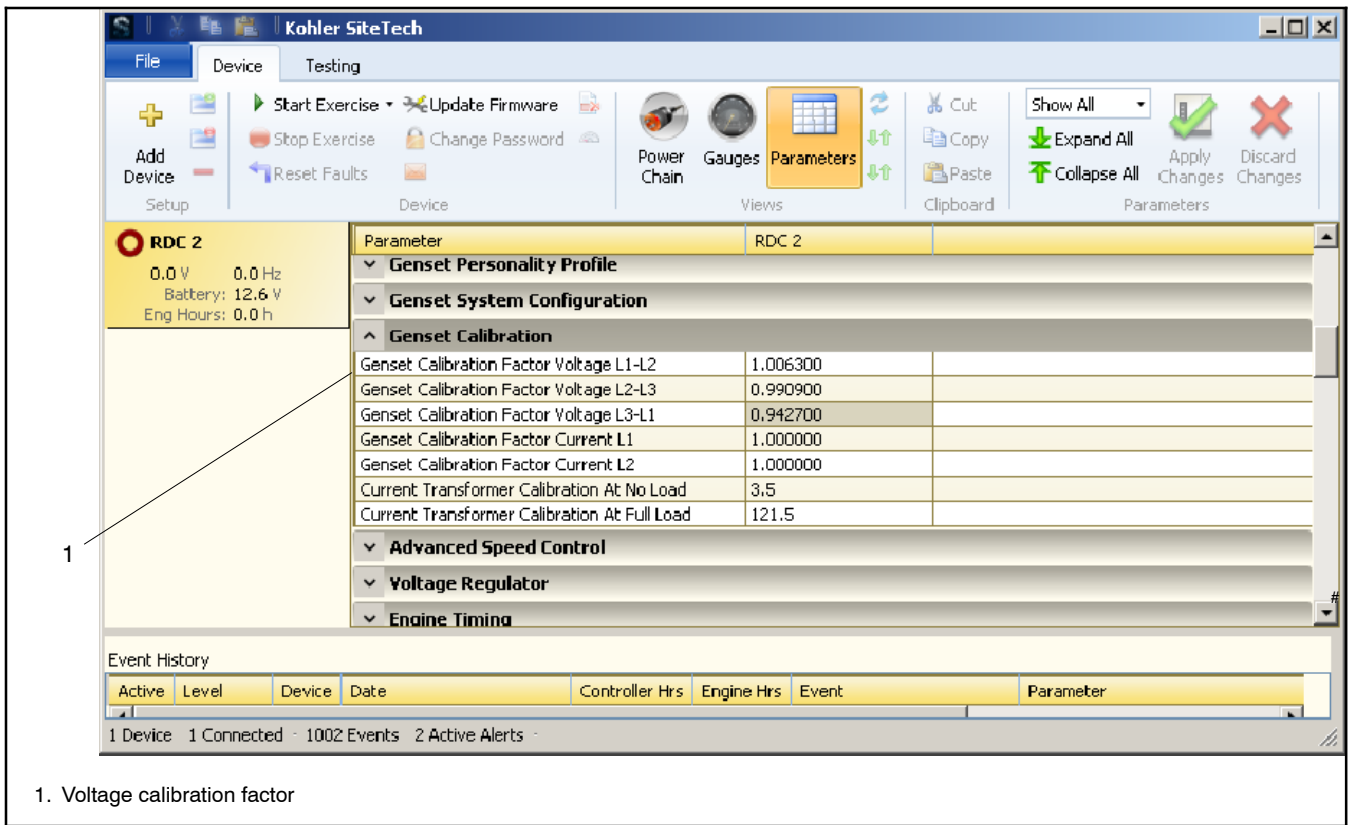

1. Voltage calibration factor

Figure 3-9 Voltage Calibration Factor in SiteTech™

Notes

Section 4 Diagrams and Drawings

This section contains dimension drawings, wiring diagrams, and schematics for the enclosed generator set. Figure 4-1 lists the drawing numbers and page numbers.

See the generator set Operation Manual for service views, if necessary.

Drawing Description	Drawing Number	Page
Dimension Drawing:		
Dimensions	ADV-8545, 1 of 2	54
Installation clearances	ADV-8545, 2 of 2	55
Wiring Diagrams:		
Schematic:		
Sheet 1	ADV-8484, 1 of 3	56
Sheet 2	ADV-8484, 2 of 3	57
Sheet 3	ADV-8484, 3 of 3	58
Wiring Diagram:		
Sheet 1	GM85226, 1 of 2	59
Sheet 2	GM85226, 2 of 2	60

Figure 4-1 Drawing Numbers and Locations

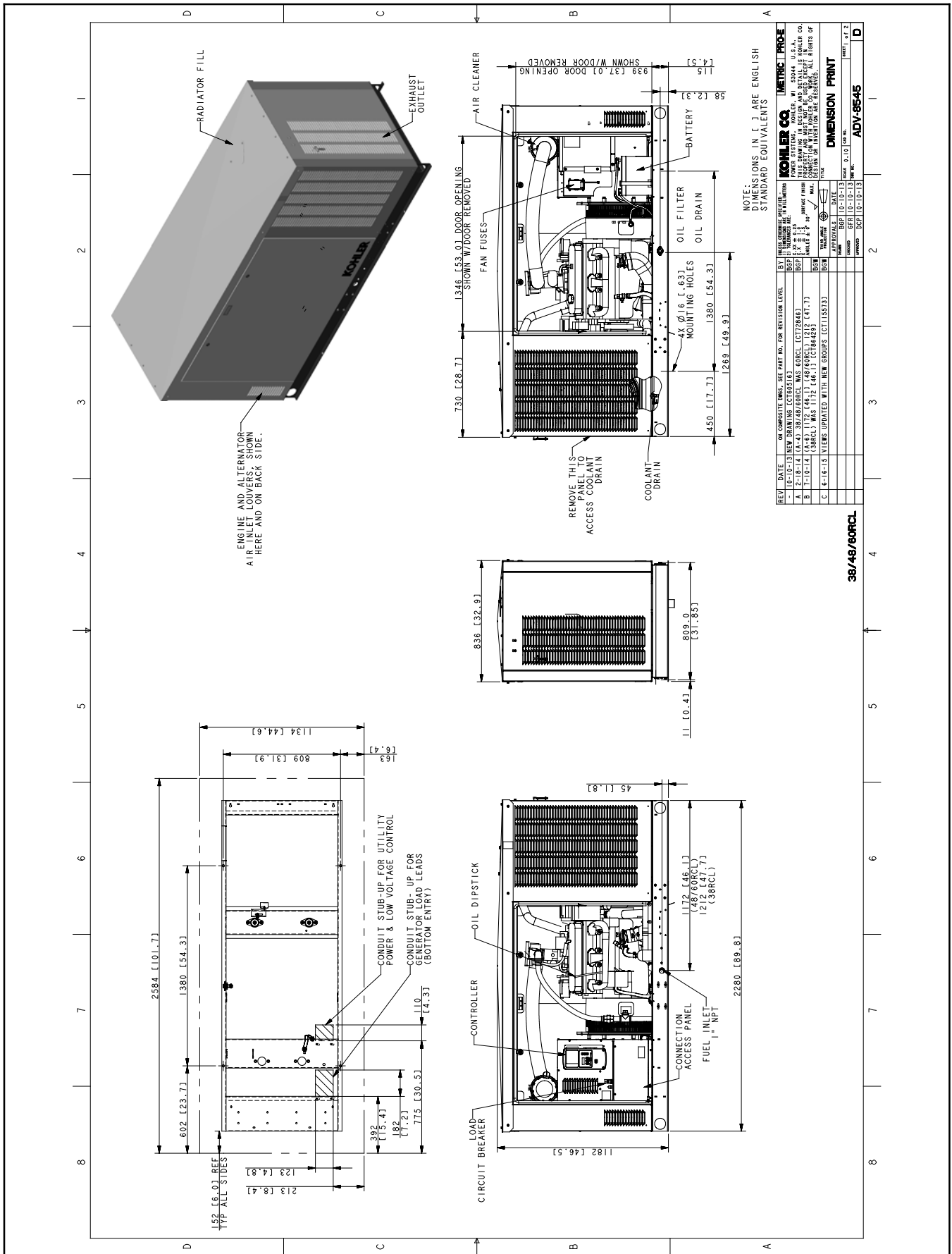

Figure 4-2 Dimension Drawing, ADV-8545, Sheet 1 of 2

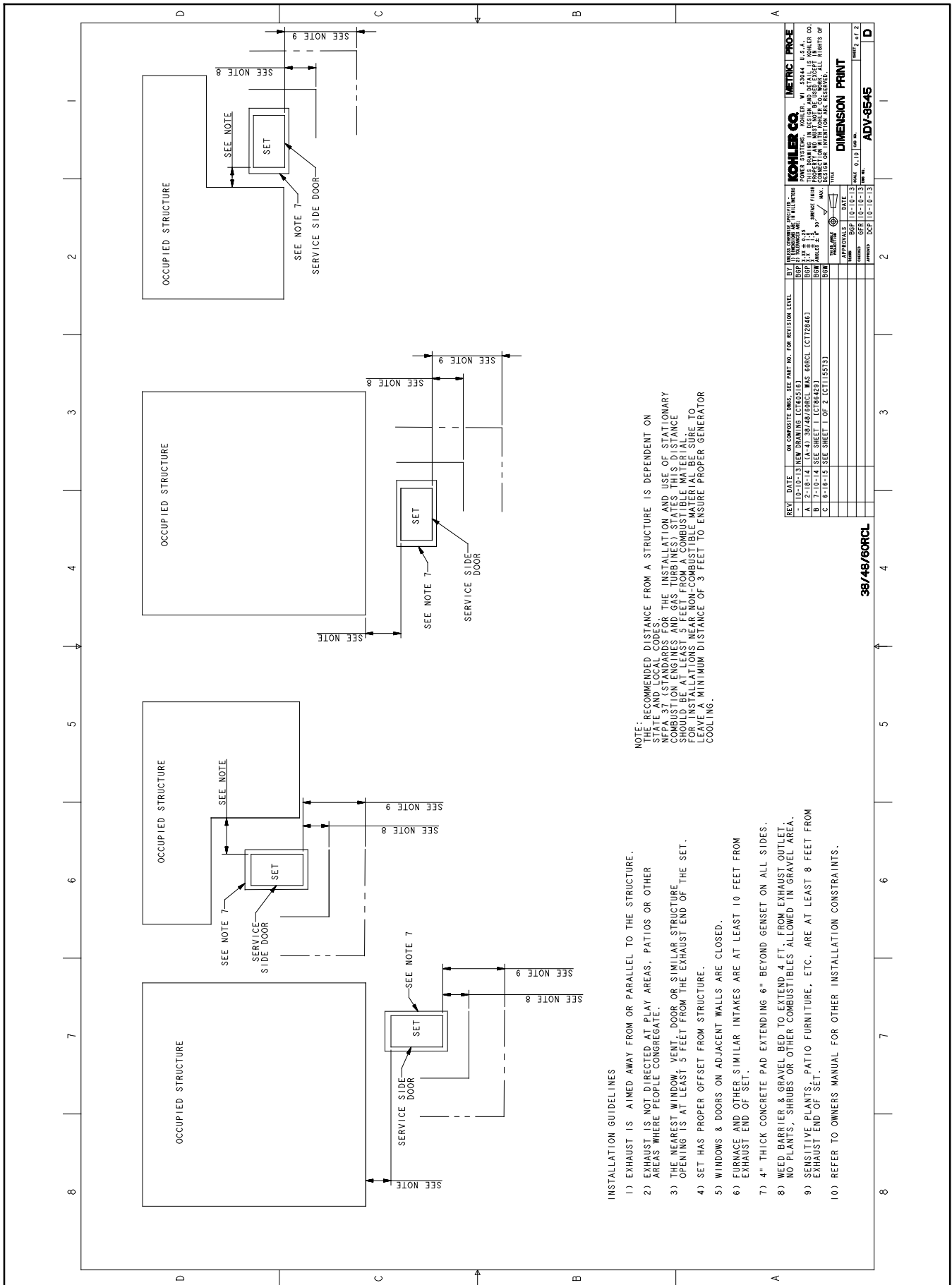

Figure 4-3 Dimension Drawing, ADV-8545, Sheet 2 of 2

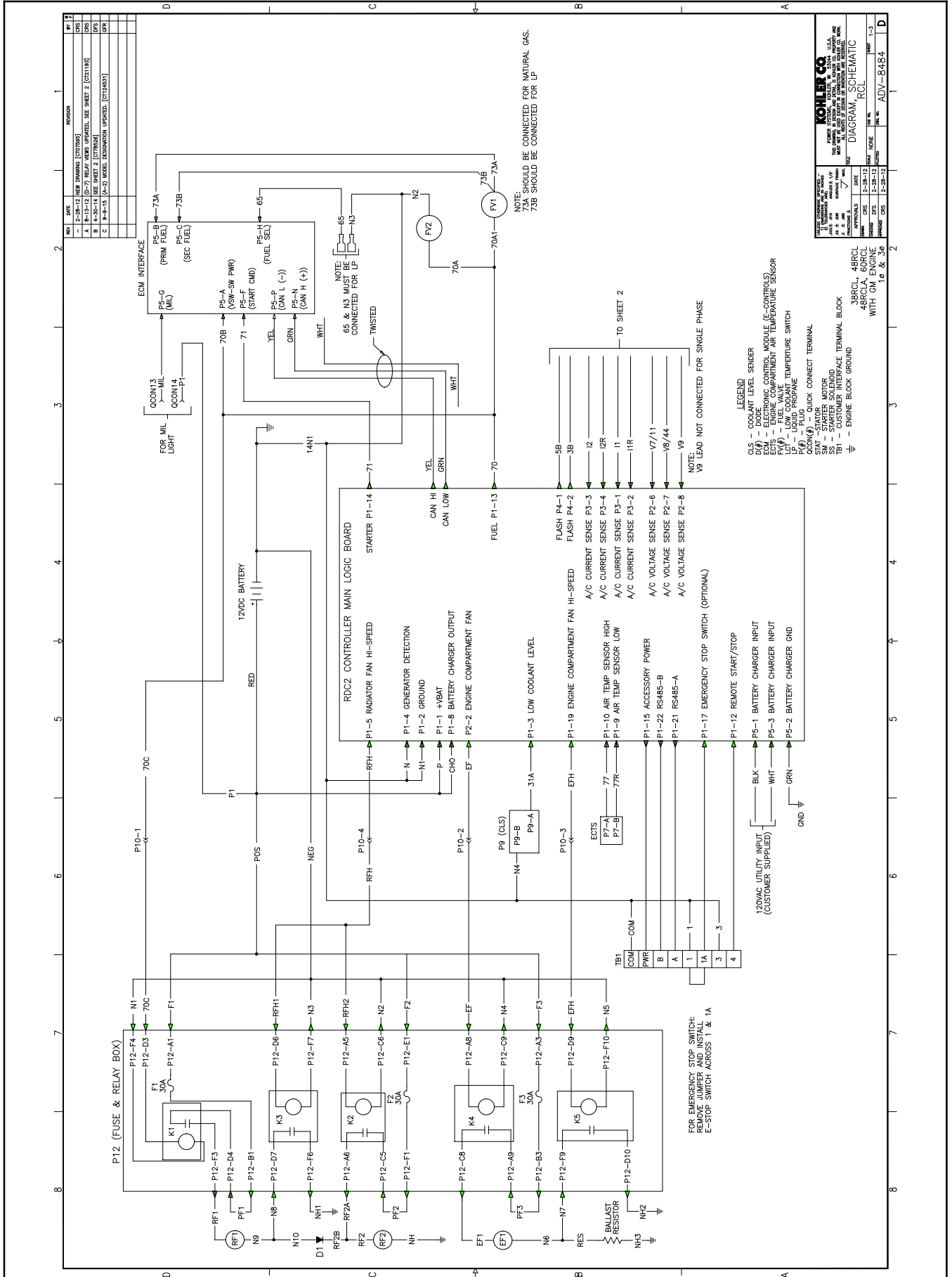

Figure 4-4 Schematic Diagram, ADV-8484, Sheet 1 of 3

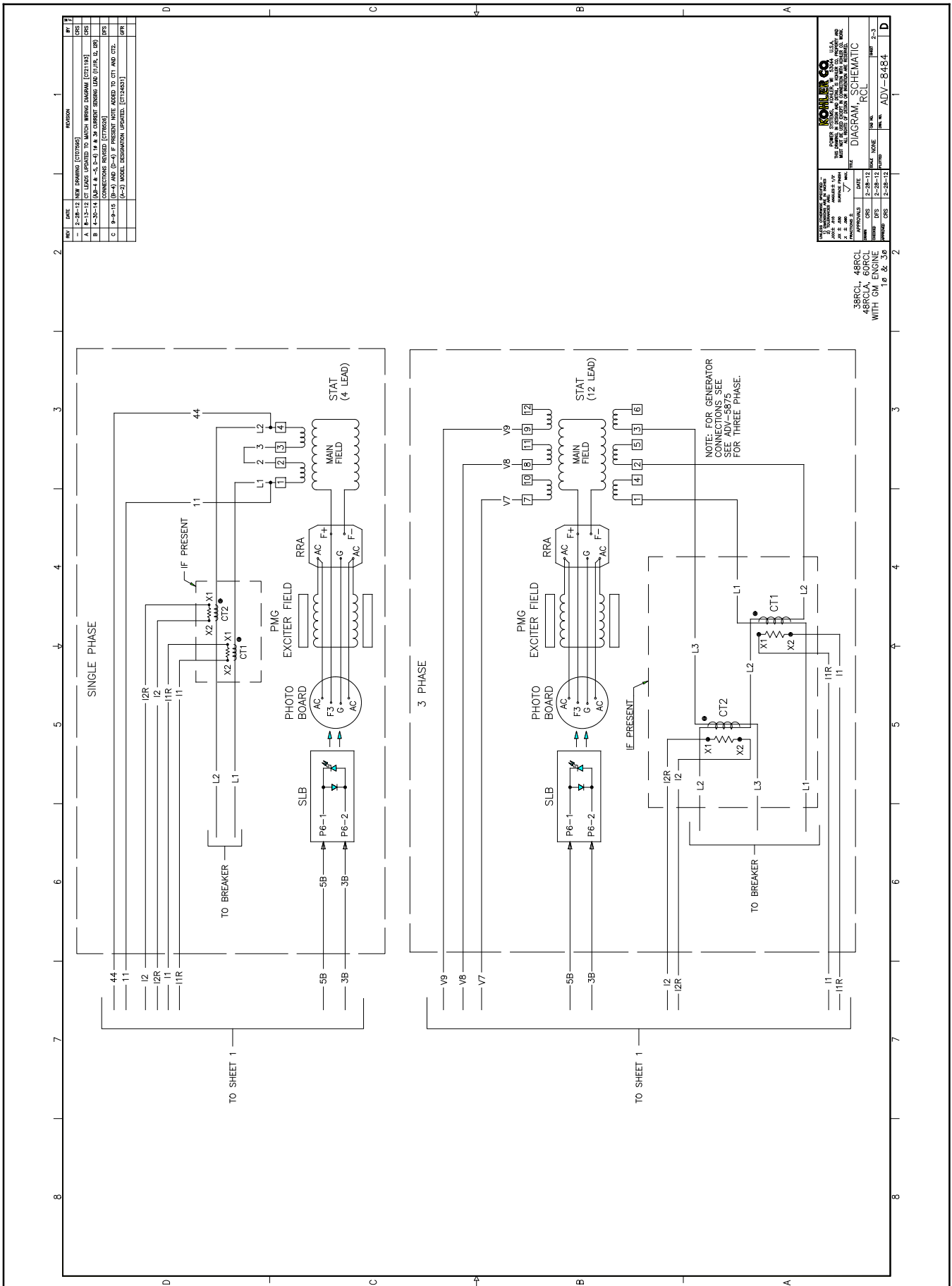

Figure 4-5 Schematic Diagram, ADV-8484, Sheet 2 of 3

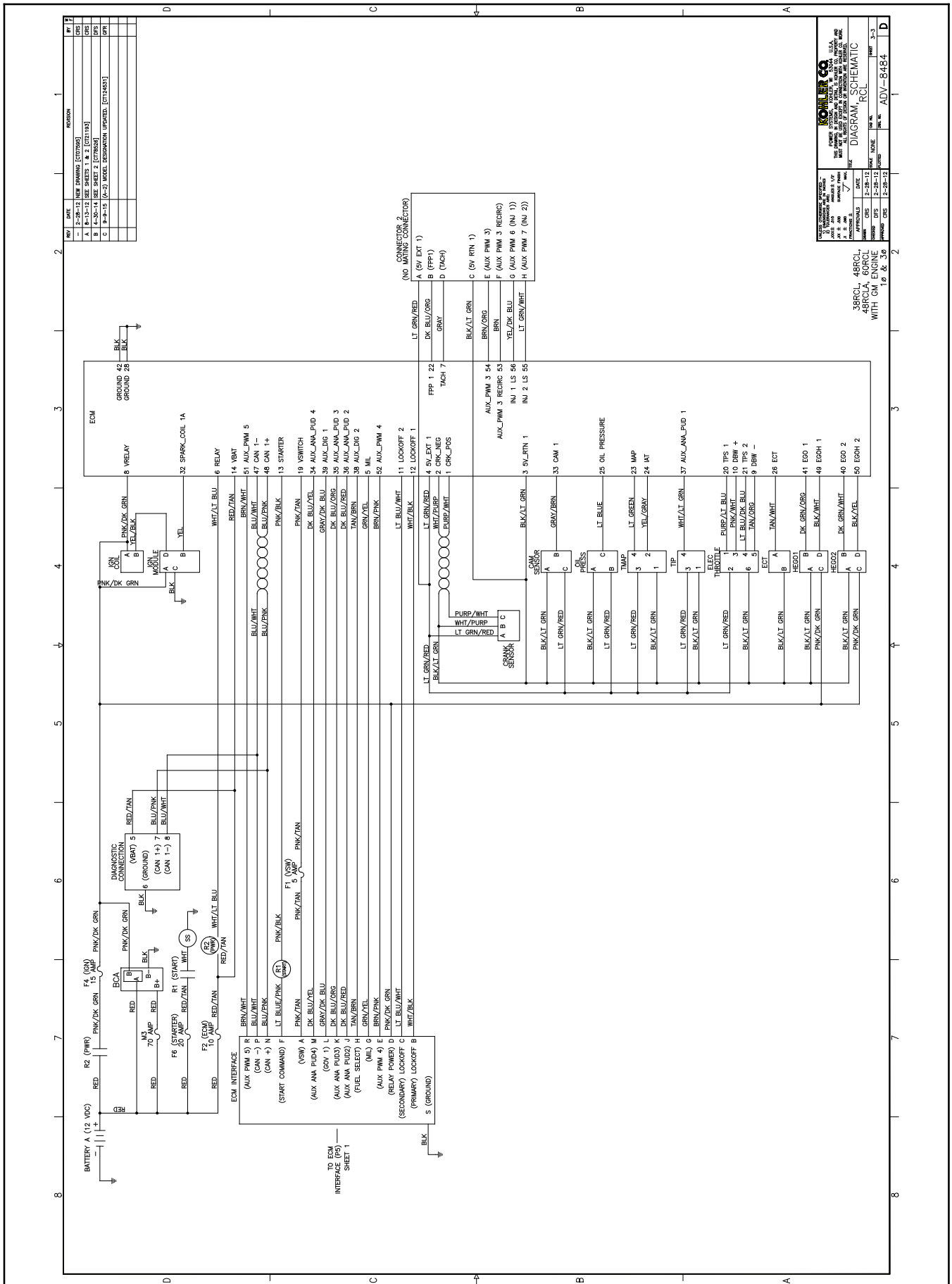

Figure 4-6 Schematic Diagram, ADV-8484, Sheet 3 of 3

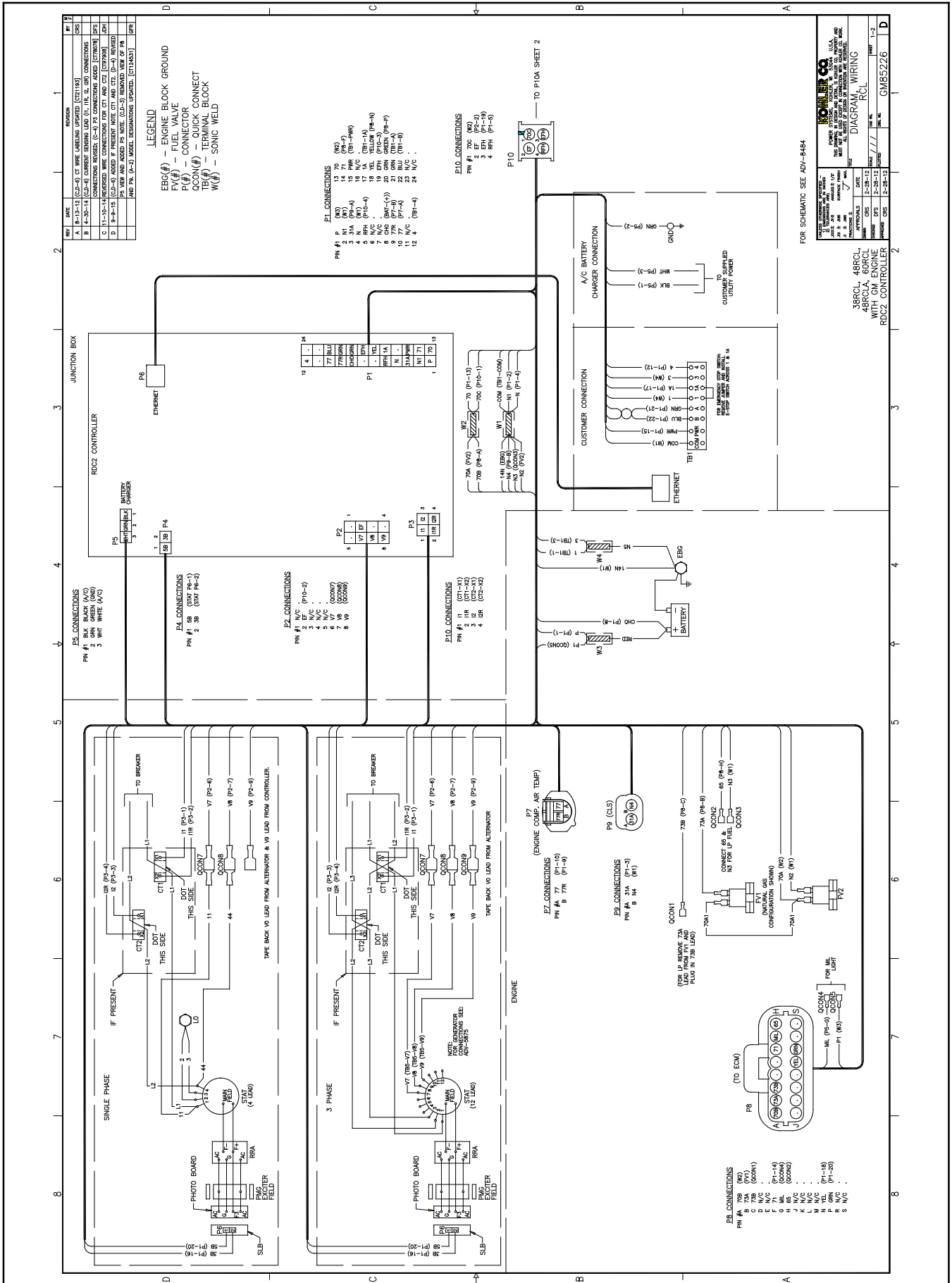

Figure 4-7 Wiring Diagram, GM85226, Sheet 1 of 2

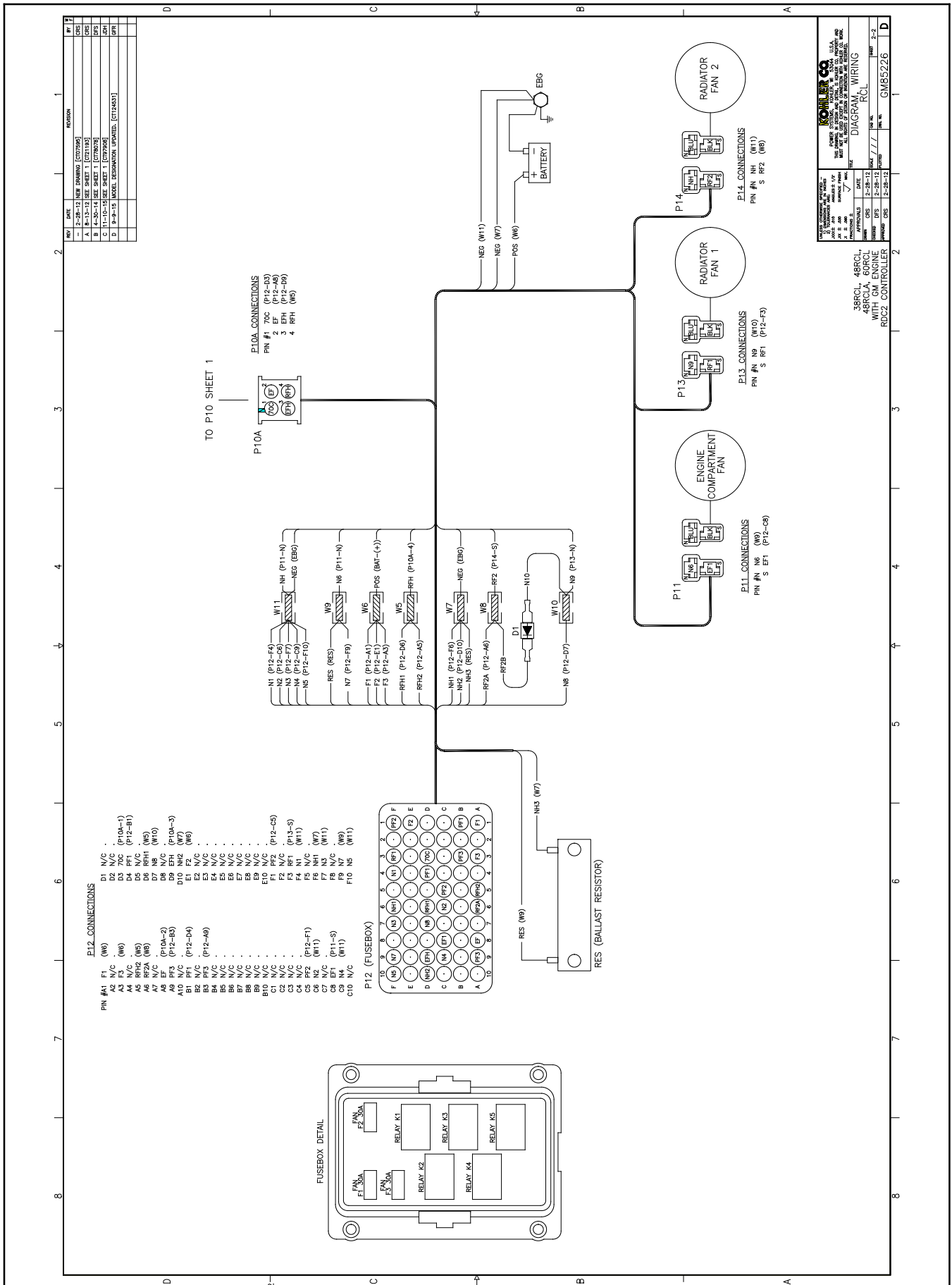

Figure 4-8 Wiring Diagram, GM85226, Sheet 2 of 2

Appendix A Abbreviations

The following list contains abbreviations that may appear in this publication.

A, amp	ampere	cfm	cubic feet per minute	exh.	exhaust
ABDC	after bottom dead center	CG	center of gravity	ext.	external
AC	alternating current	CID	cubic inch displacement	F	Fahrenheit, female
A/D	analog to digital	CL	centerline	FHM	flat head machine (screw)
ADC	advanced digital control; analog to digital converter	cm	centimeter	fl. oz.	fluid ounce
adj.	adjust, adjustment	CMOS	complementary metal oxide substrate (semiconductor)	flex.	flexible
ADV	advertising dimensional drawing	com	communications (port)	freq.	frequency
Ah	amp-hour	coml	commercial	FS	full scale
AHWT	anticipatory high water temperature	Coml/Rec	Commercial/Recreational connection	ft.	foot, feet
AISI	American Iron and Steel Institute	conn.	connection	ft. lb.	foot pounds (torque)
ALOP	anticipatory low oil pressure	cont.	continued	ft./min.	feet per minute
alt.	alternator	CPVC	chlorinated polyvinyl chloride	ftp	file transfer protocol
Al	aluminum	crit.	critical	g	gram
ANSI	American National Standards Institute (formerly American Standards Association, ASA)	CSA	Canadian Standards Association	ga.	gauge (meters, wire size)
AO	anticipatory only	CT	current transformer	gal.	gallon
APDC	Air Pollution Control District	Cu	copper	gen.	generator
API	American Petroleum Institute	cUL	Canadian Underwriter's Laboratories	genset	generator set
approx.	approximate, approximately	CUL	Canadian Underwriter's Laboratories	GFI	ground fault interrupter
APU	Auxiliary Power Unit	cu. in.	cubic inch	GND, ⊕	ground
AQMD	Air Quality Management District	cw.	clockwise	gov.	governor
AR	as required, as requested	CWC	city water-cooled	gph	gallons per hour
AS	as supplied, as stated, as suggested	cyl.	cylinder	gpm	gallons per minute
ASE	American Society of Engineers	D/A	digital to analog	gr.	grade, gross
ASME	American Society of Mechanical Engineers	DAC	digital to analog converter	GRD	equipment ground
assy.	assembly	dB	decibel	gr. wt.	gross weight
ASTM	American Society for Testing Materials	dB(A)	decibel (A weighted)	H x W x D	height by width by depth
ATDC	after top dead center	DC	direct current	HC	hex cap
ATS	automatic transfer switch	DCR	direct current resistance	HCHT	high cylinder head temperature
auto.	automatic	deg., °	degree	HD	heavy duty
aux.	auxiliary	dept.	department	HET	high exhaust temp., high engine temp.
avg.	average	dia.	diameter	hex	hexagon
AVR	automatic voltage regulator	DI/EO	dual inlet/end outlet	Hg	mercury (element)
AWG	American Wire Gauge	DIN	Deutsches Institut fur Normung e. V. (also Deutsche Industrie Normenausschuss)	HH	hex head
AWM	appliance wiring material	DIP	dual inline package	HHC	hex head cap
bat.	battery	DPDT	double-pole, double-throw	HP	horsepower
BBDC	before bottom dead center	DPST	double-pole, single-throw	hr.	hour
BC	battery charger, battery charging	DS	disconnect switch	HS	heat shrink
BCA	battery charging alternator	DVR	digital voltage regulator	hsg.	housing
BCI	Battery Council International	E ² PROM, EEPROM	electrically-erasable programmable read-only memory	HVAC	heating, ventilation, and air conditioning
BDC	before dead center	E, emer.	emergency (power source)	HWT	high water temperature
BHP	brake horsepower	ECM	electronic control module, engine control module	Hz	hertz (cycles per second)
blk.	black (paint color), block (engine)	EDI	electronic data interchange	IBC	International Building Code
blk. htr.	block heater	EFR	emergency frequency relay	IC	integrated circuit
BMEP	brake mean effective pressure	e.g.	for example (<i>exempli gratia</i>)	ID	inside diameter, identification
bps	bits per second	EG	electronic governor	IEC	International Electrotechnical Commission
br.	brass	EGSA	Electrical Generating Systems Association	IEEE	Institute of Electrical and Electronics Engineers
BTDC	before top dead center	EIA	Electronic Industries Association	IMS	improved motor starting
Btu	British thermal unit	EI/EO	end inlet/end outlet	in.	inch
Btu/min.	British thermal units per minute	EMI	electromagnetic interference	in. H ₂ O	inches of water
C	Celsius, centigrade	emiss.	emission	in. Hg	inches of mercury
cal.	calorie	eng.	engine	in. lb.	inch pounds
CAN	controller area network	EPA	Environmental Protection Agency	Inc.	incorporated
CARB	California Air Resources Board	EPS	emergency power system	ind.	industrial
CAT5	Category 5 (network cable)	ER	emergency relay	int.	internal
CB	circuit breaker	ES	engineering special, engineered special	int./ext.	internal/external
CC	crank cycle	ESD	electrostatic discharge	I/O	input/output
cc	cubic centimeter	est.	estimated	IP	internet protocol
CCA	cold cranking amps	E-Stop	emergency stop	ISO	International Organization for Standardization
ccw.	counterclockwise	etc.	et cetera (and so forth)	J	joule
CEC	Canadian Electrical Code			JIS	Japanese Industry Standard
cert.	certificate, certification, certified			k	kilo (1000)
cfh	cubic feet per hour			K	kelvin
				kA	kiloampere
				KB	kilobyte (2 ¹⁰ bytes)
				KBus	Kohler communication protocol
				kg	kilogram

kg/cm ²	kilograms per square centimeter	NC	normally closed	RTU	remote terminal unit
kgm	kilogram-meter	NEC	National Electrical Code	RTV	room temperature vulcanization
kg/m ³	kilograms per cubic meter	NEMA	National Electrical Manufacturers Association	RW	read/write
kHz	kilohertz	NFPA	National Fire Protection Association	SAE	Society of Automotive Engineers
kJ	kilojoule	Nm	newton meter	scfm	standard cubic feet per minute
km	kilometer	NO	normally open	SCR	silicon controlled rectifier
kOhm, kΩ	kilo-ohm	no., nos.	number, numbers	s, sec.	second
kPa	kilopascal	NPS	National Pipe, Straight	SI	<i>Systeme international d'unites</i> , International System of Units
kph	kilometers per hour	NPSC	National Pipe, Straight-coupling	SI/EO	side in/end out
kV	kilovolt	NPT	National Standard taper pipe thread per general use	sil.	silencer
kVA	kilovolt ampere	NPTF	National Pipe, Taper-Fine	SMTP	simple mail transfer protocol
kVAR	kilovolt ampere reactive	NR	not required, normal relay	SN	serial number
kW	kilowatt	ns	nanosecond	SNMP	simple network management protocol
kWh	kilowatt-hour	OC	overcrank	SPDT	single-pole, double-throw
kWm	kilowatt mechanical	OD	outside diameter	SPST	single-pole, single-throw
kWth	kilowatt-thermal	OEM	original equipment manufacturer	spec	specification
L	liter	OF	overfrequency	specs	specification(s)
LAN	local area network	opt.	option, optional	sq.	square
L x W x H	length by width by height	OS	oversize, overspeed	sq. cm	square centimeter
lb.	pound, pounds	OSHA	Occupational Safety and Health Administration	sq. in.	square inch
lbm/ft ³	pounds mass per cubic feet	OV	overvoltage	SMS	short message service
LCB	line circuit breaker	oz.	ounce	SS	stainless steel
LCD	liquid crystal display	p., pp.	page, pages	std.	standard
LED	light emitting diode	PC	personal computer	stl.	steel
Lph	liters per hour	PCB	printed circuit board	tach.	tachometer
Lpm	liters per minute	pF	picofarad	TB	terminal block
LOP	low oil pressure	PF	power factor	TCP	transmission control protocol
LP	liquefied petroleum	ph., ∅	phase	TD	time delay
LPG	liquefied petroleum gas	PHC	Phillips® head CrimpTite® (screw)	TDC	top dead center
LS	left side	PHH	Phillips® hex head (screw)	TDEC	time delay engine cooldown
L _{wa}	sound power level, A weighted	PHM	pan head machine (screw)	TDEN	time delay emergency to normal
LWL	low water level	PLC	programmable logic control	TDES	time delay engine start
LWT	low water temperature	PLC	programmable logic control	TDNE	time delay normal to emergency
m	meter, milli (1/1000)	PMG	permanent magnet generator	TDOE	time delay off to emergency
M	mega (10 ⁶ when used with SI units), male	pot	potentiometer, potential	TDON	time delay off to normal
m ³	cubic meter	ppm	parts per million	temp.	temperature
m ³ /hr.	cubic meters per hour	PROM	programmable read-only memory	term.	terminal
m ³ /min.	cubic meters per minute	psi	pounds per square inch	THD	total harmonic distortion
mA	milliampere	psig	pounds per square inch gauge	TIF	telephone influence factor
man.	manual	pt.	pint	tol.	tolerance
max.	maximum	PTC	positive temperature coefficient	turbo.	turbocharger
MB	megabyte (2 ²⁰ bytes)	PTO	power takeoff	typ.	typical (same in multiple locations)
MCCB	molded-case circuit breaker	PVC	polyvinyl chloride	UF	underfrequency
MCM	one thousand circular mils	qt.	quart, quarts	UHF	ultrahigh frequency
megggar	megohmmeter	qty.	quantity	UIF	user interface
MHz	megahertz	R	replacement (emergency)	UL	Underwriter's Laboratories, Inc.
mi.	mile	rad.	radiator, radius	UNC	unified coarse thread (was NC)
mil	one one-thousandth of an inch	RAM	random access memory	UNF	unified fine thread (was NF)
min.	minimum, minute	RBUS	RS-485 proprietary communications	univ.	universal
misc.	miscellaneous	RDO	relay driver output	URL	uniform resource locator (web address)
MJ	megajoule	ref.	reference	US	undersize, underspeed
mJ	millijoule	rem.	remote	UV	ultraviolet, undervoltage
mm	millimeter	Res/Coml	Residential/Commercial	V	volt
mOhm, mΩ	milliohm	RFI	radio frequency interference	VAC	volts alternating current
MOhm, MΩ	megohm	RH	round head	VAR	voltampere reactive
MOV	metal oxide varistor	RHM	round head machine (screw)	VDC	volts direct current
MPa	megapascal	rly.	relay	VFD	vacuum fluorescent display
mpg	miles per gallon	rms	root mean square	VGA	video graphics adapter
mph	miles per hour	rnd.	round	VHF	very high frequency
MS	military standard	RO	read only	W	watt
ms	millisecond	ROM	read only memory	WCR	withstand and closing rating
m/sec.	meters per second	rot.	rotate, rotating	w/	with
mtg.	mounting	rpm	revolutions per minute	WO	write only
MTU	Motoren-und Turbinen-Union	RS	right side	w/o	without
MW	megawatt	RTDs	Resistance Temperature Detectors	wt.	weight
mW	milliwatt			xfmr	transformer
μF	microfarad				
N, norm.	normal (power source)				
NA	not available, not applicable				
nat. gas	natural gas				
NBS	National Bureau of Standards				

KOHLER[®] Power Systems

KOHLER CO. Kohler, Wisconsin 53044
Phone 920-457-4441, Fax 920-459-1646

Kohler Power Systems
Asia Pacific Headquarters
7 Jurong Pier Road
Singapore 619159
Phone (65) 6264-6422, Fax (65) 6264-6455

**For the nearest KOHLER authorized
installation, service, and sales dealer in
the US and Canada:
Call 1-800-544-2444 or visit
KOHLERPower.com**

TP-6809 7/16d

Original Instructions (English)

© 2012, 2013, 2015, 2016 by Kohler Co. All rights reserved.