

INSTALLATION INSTRUCTIONS

Original Issue Date: **8/04**

Model: **80-500 kW Diesel Generator Sets**

Market: **Industrial**

Subject: **Remote Speed Adjusting Control Kits GM31214-KP1 and GM31214-KP2**

Introduction

This kit provides remote engine speed adjustments with an approximate range of $\pm 5\%$ at 1800 rpm.

Read the entire installation procedure and compare the kit parts with the parts list in this publication before beginning installation. Perform the steps in the order shown.

Observe applicable local and national electrical codes when installing the wiring system.

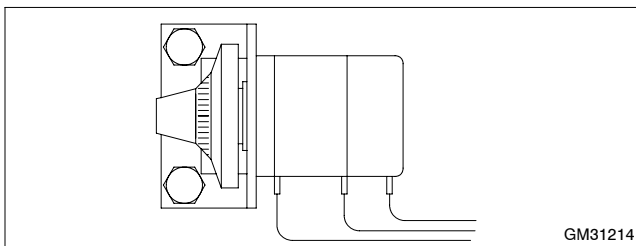

Figure 1 Remote Speed Adjusting Control

Safety Precautions

Observe the following safety precautions when installing the kit.

⚠ WARNING

Accidental starting. Can cause severe injury or death.

Disconnect the battery cables before working on the generator set. Remove the negative (-) lead first when disconnecting the battery. Reconnect the negative (-) lead last when reconnecting the battery.

Disabling the generator set. Accidental starting can cause severe injury or death. Before working on the generator set or connected equipment, disable the generator set as follows: (1) Move the generator set master switch to the

OFF position. (2) Disconnect the power to the battery charger. (3) Remove the battery cables, negative (-) lead first. Reconnect the negative (-) lead last when reconnecting the battery. Follow these precautions to prevent starting of the generator set by an automatic transfer switch, remote start/stop switch, or engine start command from a remote computer.

⚠ WARNING

Hazardous voltage. Moving parts. Can cause severe injury or death.

Operate the generator set only when all guards and electrical enclosures are in place.

Short circuits. Hazardous voltage/current can cause severe injury or death. Short circuits can cause bodily injury and/or equipment damage. Do not contact electrical connections with tools or jewelry while making adjustments or repairs. Remove all jewelry before servicing the equipment.

Battery short circuits. Explosion can cause severe injury or death. Short circuits can cause bodily injury and/or equipment damage. Disconnect the battery before generator set installation or maintenance. Remove all jewelry before servicing the equipment. Use tools with insulated handles. Remove the negative (-) lead first when disconnecting the battery. Reconnect the negative (-) lead last when reconnecting the battery. Never connect the negative (-) battery cable to the positive (+) connection terminal of the starter solenoid. Do not test the battery condition by shorting the terminals together.

Installation Procedure

- 1. Remove the generator set from service.**
 - 1.1 Place the generator set master switch in the OFF/RESET position.
 - 1.2 Disconnect the power to the battery charger, if equipped.
 - 1.3 Disconnect the generator set engine starting battery(ies), negative (-) lead first.

2. Install the speed potentiometer.

Note: The following instruction describes mounting the potentiometer in the junction box. Some switchgear applications may require the potentiometer kit installed with the switchgear components.

- 2.1 Remove the junction box panel(s) and screws.
- 2.2 Select a location on the junction box for mounting the kit. Recommended locations are shown in Figure 2, Figure 3, and Figure 4.
- 2.3 Use the bracket (GM30860) as a template and drill two 6.4 mm (0.25 in.) holes in junction box.
- 2.4 Remove burrs from holes and clean up metal chips.

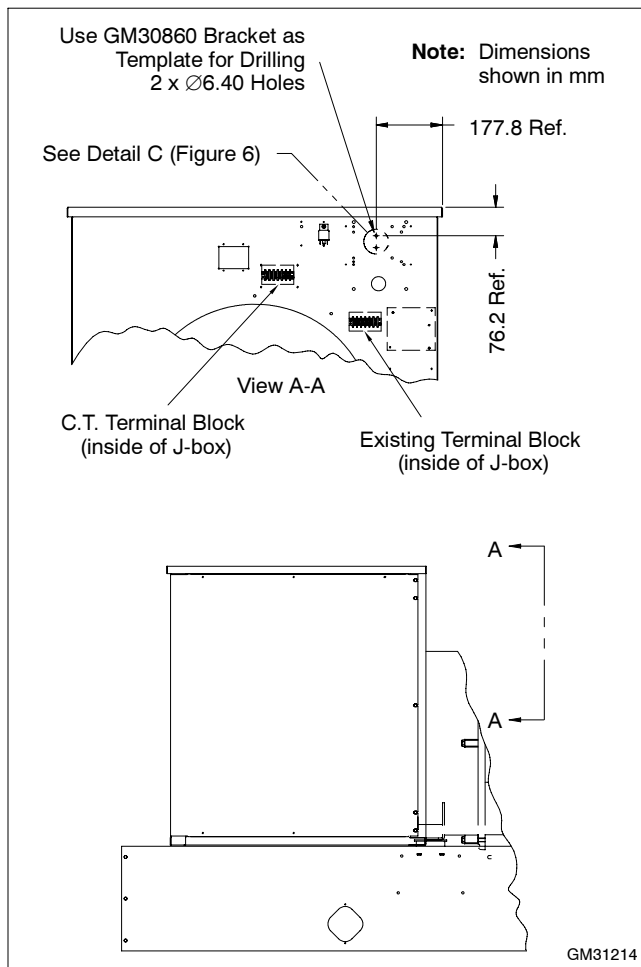

Figure 2 Kit GM31214-KA1, 80-300 kW

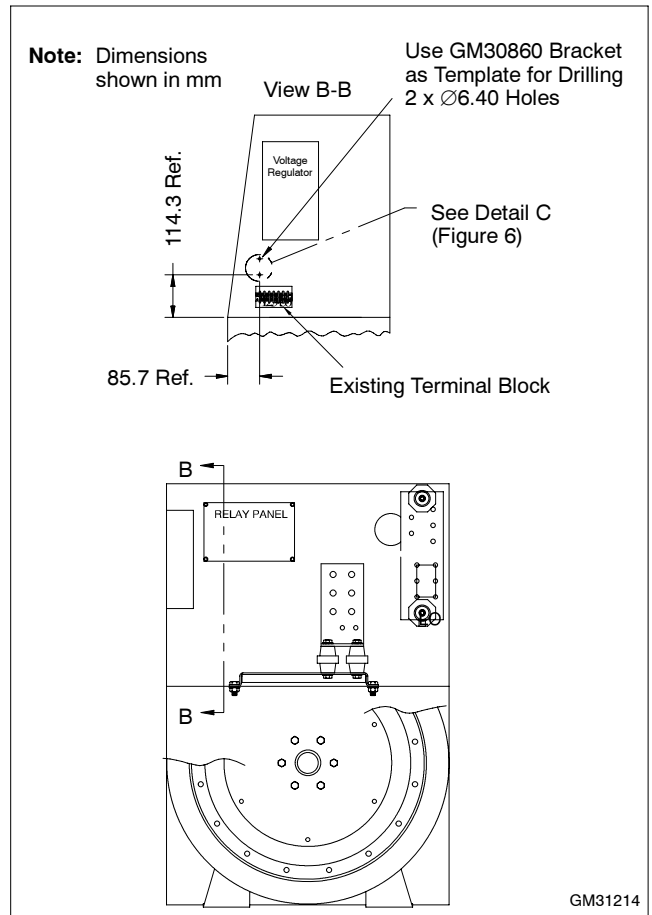

Figure 3 Kit GM31214-KA1, 350/400 kW

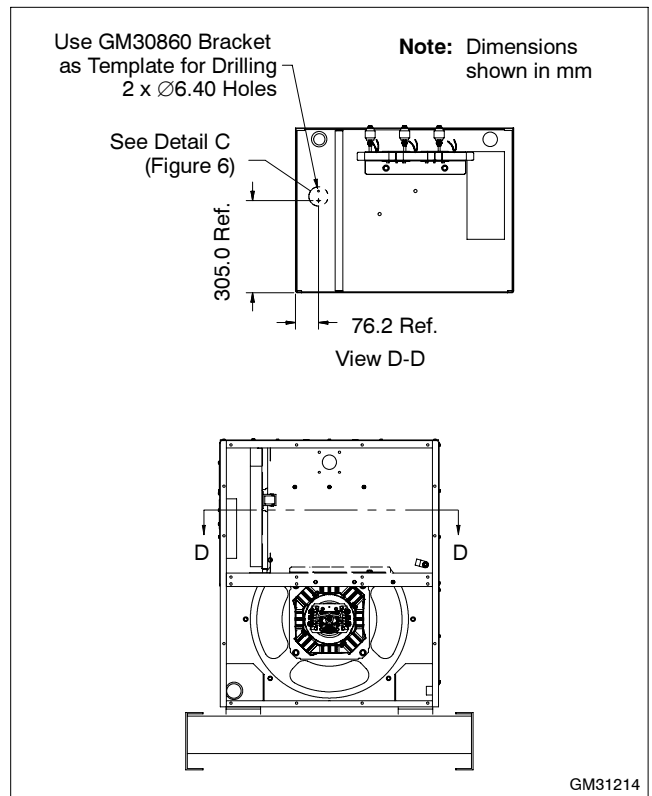

Figure 4 Kit GM31214-KA2, 450/500 kW

- 2.5 With bracket (GM30860) surfaces clean and dry, attach decal (GM30862) as shown in Figure 5.

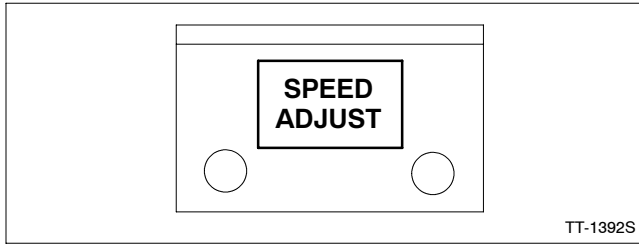

Figure 5 Bracket with Decal Attached

- 2.6 Attach the bracket (GM30860) to the inside of the junction box using two screws (M933-06014-60) and nuts (M6923-06-80) as shown in Figure 6. Mount the bracket so the decal side of the bracket is facing toward the user.
- 2.7 Remove the knob/dial and locknut from the potentiometer shaft.
- 2.8 Place the potentiometer shaft through the bracket hole with the shaft end on the decal side of the bracket and install locknut. Rotate the potentiometer assembly so that the potentiometer metal tab aligns with the bracket index hole and tighten the locknut.
- 2.9 Install the knob/dial on the potentiometer shaft. Tighten the knob/dial set screw.
- 2.10 Rotate the knob/dial to the approximate midpoint of the adjustment range.

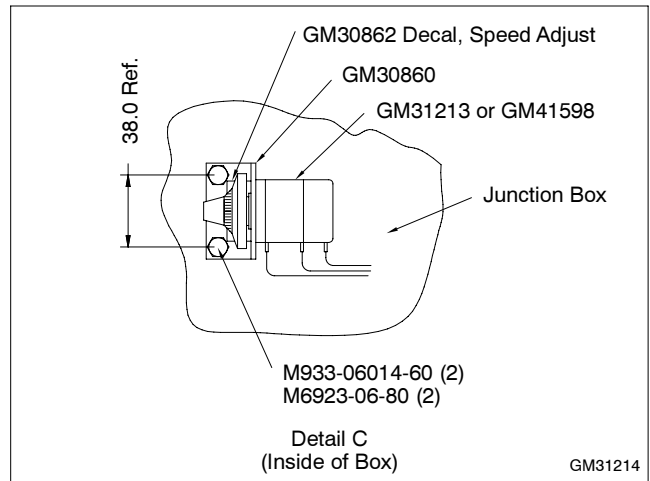

Figure 6 Remote Speed Potentiometer and Bracket

3. Attach the wiring harness.

- 3.1 Route the wiring harness attached to the potentiometer to the existing terminal block mounted in the junction box (or to the 550 controller on the 450/500REOZVB models only).
- 3.2 Connect the red, black, and white leads to the governor controller terminal strip as shown in Figure 7 (or see Figure 8 for terminal strip connections on the 550 controller with 450/500REOZVB models only).
- 3.3 Coil the excess wiring harness and secure to the engine wiring harness with a cable tie or electrical tape (not supplied).

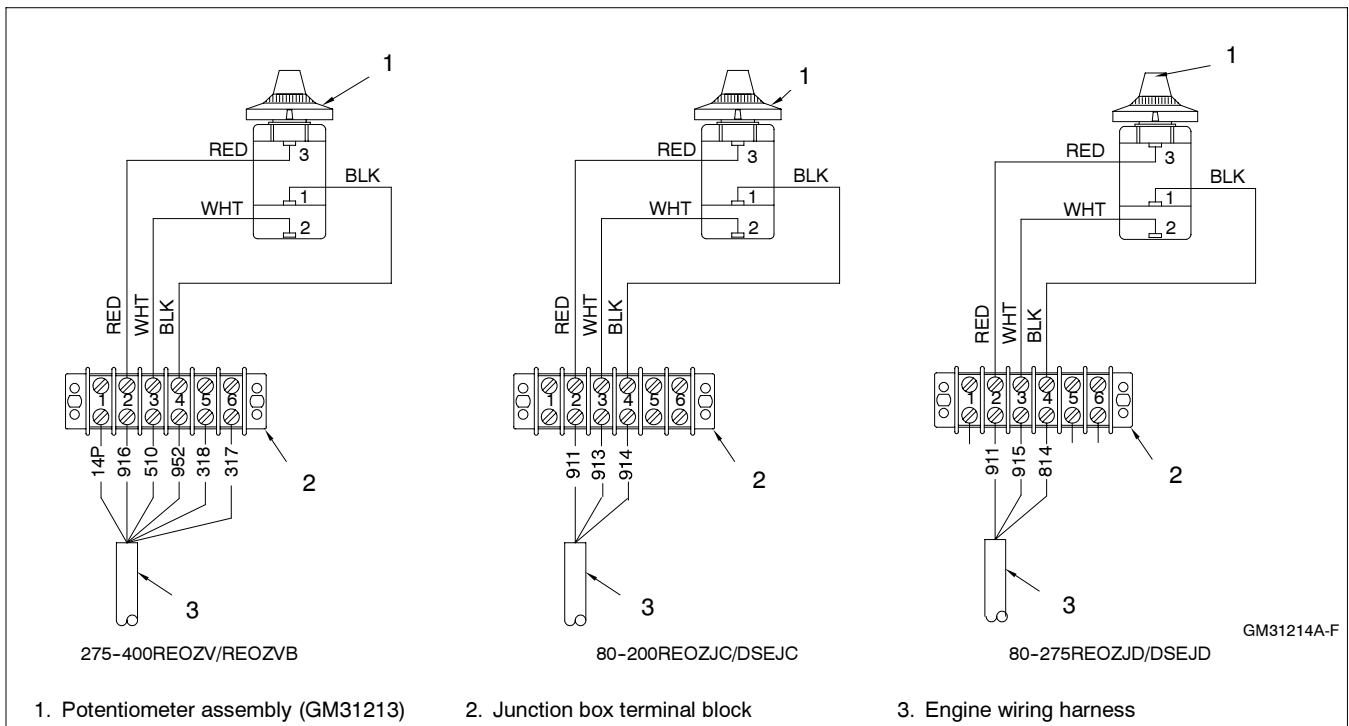

Figure 7 Speed Adjusting Control Wiring Diagram

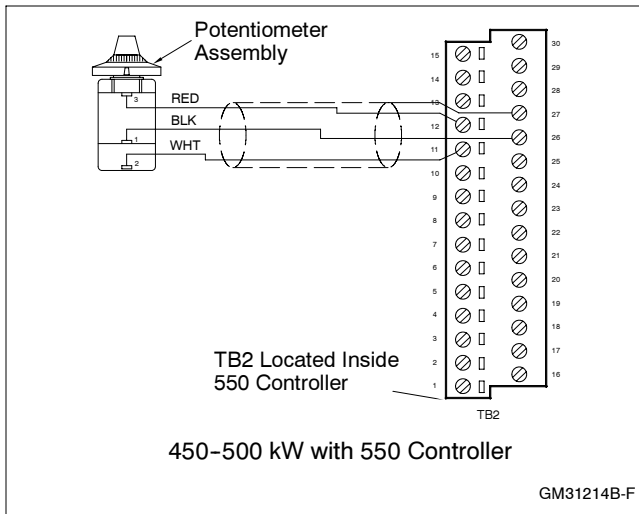

Figure 8 Speed Adjusting Control Wiring Diagram

4. Place the generator set into service.

- 4.1 Place the generator set master switch in the OFF/RESET position.
- 4.2 Reconnect the generator set engine starting battery(ies), negative (-) lead last.
- 4.3 Reconnect the power to the battery charger, if equipped.
- 4.4 Move the generator set master switch to AUTO for startup by remote transfer switch or remote start/stop switch.

5. Reset the engine controls (275-400REOZV models only).

- 5.1 Locate the engine control box in the junction box. See Figure 9.

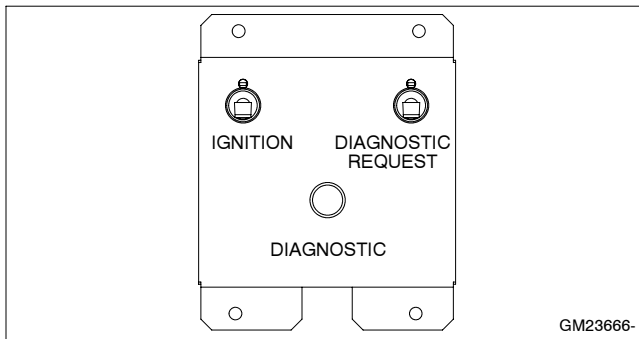

Figure 9 Engine Control Box

- 5.2 First press and hold down the DIAGNOSTIC REQUEST switch and then press and hold down the IGNITION switch. Keep the switches held down at least 6 seconds and then release the switches.
- 5.3 Install the junction box panel(s) and screws.

6. Calibrate 550 controller analog input 06 (450/500REOZVB models only).

Refer to the 550 Controller Operation Manual, TP-6200, as needed.

- 6.1 Go to Menu 14, Programming Mode.
- 6.2 Press the down arrow key to Programming Mode. Press the arrow right key to Programming Mode—Local and press the Yes key.
- 6.3 Go to Menu 12, Calibration.
- 6.4 Press the down arrow to Scale AC Analog Inputs.
- 6.5 Press right arrow to Scale Aux. Analog Inputs.
- 6.6 Press the down arrow to Zero Aux. Analog Inputs.
- 6.7 Disconnect the P2 ribbon cable from the interconnection circuit board on controller back panel. See Figure 10 and Figure 11.

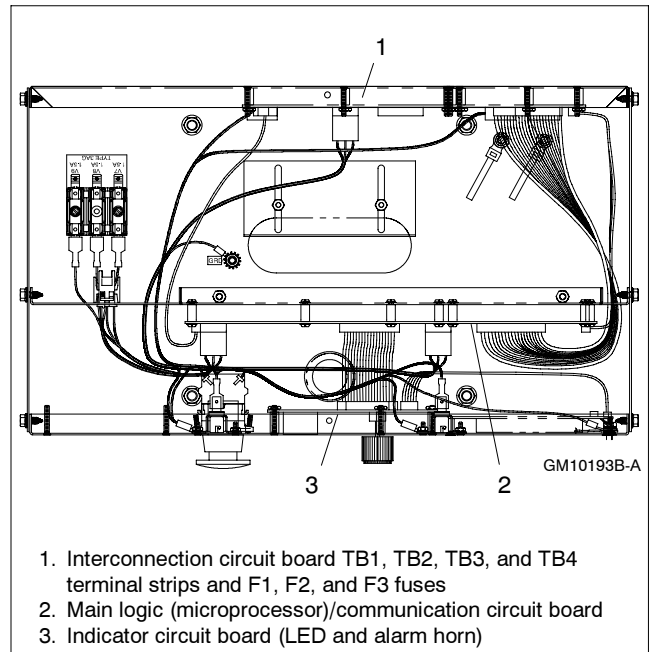

Figure 10 Controller Circuit Boards and Fuses (Controller Top View)

- 6.8 Press the Yes key.
- 6.9 Press the Enter key.
- 6.10 Reattach P2 ribbon cable to the interconnection circuit board.
- 6.11 Press the down arrow key, as needed, to Analog (Input) 06, Scale Value 1.

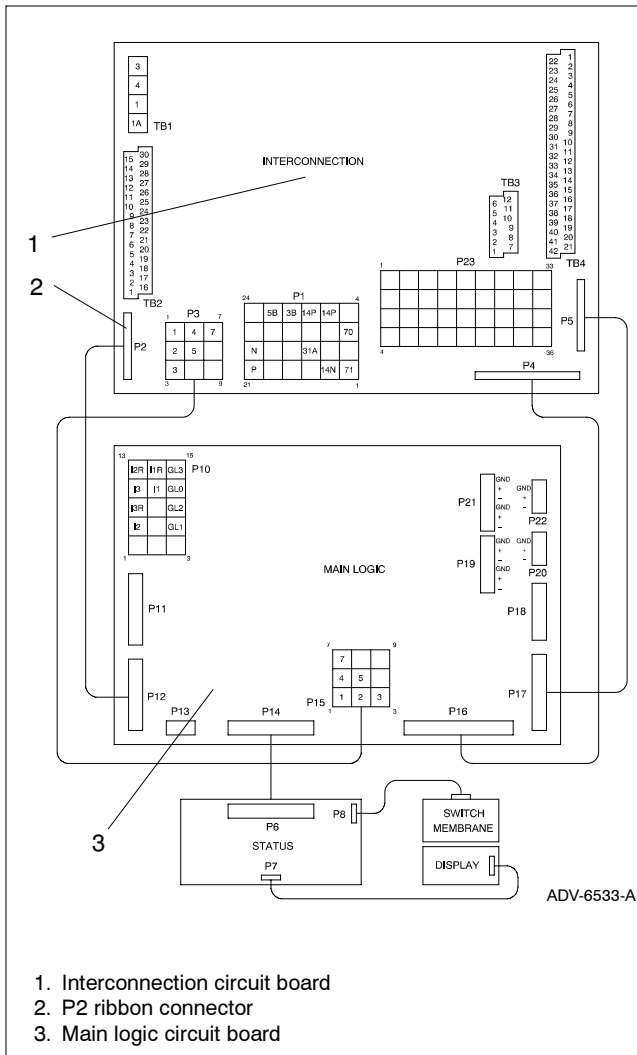

Figure 11 Interconnection Circuit Board Ribbon Connector P2 (Top View of Circuit Board)

- 6.12 Turn the speed adjusting potentiometer fully counterclockwise to approximately 0.5 volts as shown in the SCAL 1 display and enter 1250 using the controller keypad.
- 6.13 Press the Enter key.
- 6.14 Turn the speed adjusting potentiometer fully clockwise to approximately 4.5 volts as shown in the SCAL 2 display and enter 8750 using the controller keypad.
- 6.15 Press the Enter key.
- 6.16 Go to Menu 9, Input Setup.

- 6.17 Press the down arrow key to Setup Digital Auxiliary Inputs.
- 6.18 Press the right arrow key to Setup Analog Auxiliary Inputs.
- 6.19 Press the down arrow key to Analog Input 06.
- 6.20 Press the right arrow key to check that Warning Enabled indicates No. If Yes is displayed, press the No key and then the Enter key.
- 6.21 Press the right arrow key to check that Analog Input 06 Shutdown Enabled indicates No. If Yes is displayed, press the No key and then the Enter key.
- 6.22 Go to Menu 14, Programming Mode.
- 6.23 Press the down arrow key to Programming Mode. Press the arrow right key to Programming Mode—Off and press the Yes key.

Parts List

Remote Speed Adjusting Control Kit

Kit: GM31214-KP1		
Qty.	Description	Part Number
1	Potentiometer assembly (includes *)	GM31213
1	* Potentiometer	X-6136-19
1	* Knob/dial	X-6136-9
1	* Harness, wiring	—
1	* Nut, lock	—
1	Bracket	GM30860
1	Decal, speed adjust	GM30862
2	Screw, hex cap	M933-06014-60
2	Nut, hex, 6 mm	M6923-06-80
Kit: GM31214-KP2		
Qty.	Description	Part Number
1	Potentiometer assembly (includes *)	GM41598
1	* Potentiometer	X-6136-19
1	* Knob/dial	X-6136-9
1	* Harness, wiring	—
1	* Nut, lock	—
1	Bracket	GM30860
1	Decal, speed adjust	GM30862
2	Screw, hex cap	M933-06014-60
2	Nut, hex, 6 mm	M6923-06-80

