

# Operation and Installation Instructions

## Automatic Battery Chargers

### **Kits:**

PA-320741 through PA-320764 and  
PA-320741-SD through PA-320764-SD

# Table of Contents

<b>SUBJECT</b>	<b>PAGE</b>	<b>SUBJECT</b>	<b>PAGE</b>
<b>Safety Precautions and Instructions</b> .....	1	Charger Voltage Adjustment .....	15
<b>Introduction</b> .....	4	Charger and Battery Maintenance .....	15
<b>Specifications</b> .....	5	<b>Troubleshooting</b> .....	16
<b>Installing Charger</b> .....	8	<b>Standard Accessories</b> .....	17
Mount Charger .....	9	Current Limiting .....	17
Output Connections .....	9	Reverse Polarity Protection .....	17
Input Connections .....	9	Automatic Float Operation .....	17
<b>Disconnecting Charger</b> .....	11	Temperature Compensation .....	17
<b>Battery Charger Operation</b> .....	12	AC Input Fuse .....	17
Charging Lead-Acid Batteries .....	12	DC Output Fuse .....	17
Checking Specific Gravity .....	14	Power On Lamp .....	17
Charging Nickel-Cadmium Batteries .....	14	<b>Wiring Diagrams</b> .....	18
		<b>Parts Lists</b> .....	24

# Safety Precautions and Instructions

A generator set, like any other electro-mechanical device, can pose potential dangers to life and limb if improperly maintained or imprudently operated. The best way to prevent accidents is to be aware of the potential dangers and to always use good common sense. In the interest of safety, some general precautions relating to the operating of a generator set follow. Keep these in mind. This manual contains several types of safety precautions which are explained below.

## DANGER

Danger is used to indicate the presence of a hazard that will cause severe personal injury, death, or substantial property damage if the warning is ignored.

## WARNING

Warning is used to indicate the presence of a hazard that can cause severe personal injury, death, or substantial property damage if the warning is ignored.

## CAUTION

Caution is used to indicate the presence of a hazard that will or can cause minor personal injury or property damage if the warning is ignored.

## NOTE

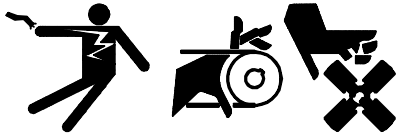
Note is used to notify people of installation, operation, or maintenance information that is important but not hazard-related.

Safety decals are affixed to the generator set in prominent places to advise the operator or service technician of potentially hazardous situations. The decals are reproduced here to improve operator recognition and thereby increase decal effectiveness. For a further explanation of decal information, reference the accompanying safety precautions. Before operating or servicing the generator set, be sure you understand the message of these decals. Replace decals if missing or damaged.

## Accidental Starting

---

### WARNING



#### **Accidental starting.**



#### **Can cause severe injury or death.**

Disconnect battery cables before working on generator set (negative lead first and reconnect it last).

---

**Accidental starting can cause severe injury or death.** Turn generator master switch to OFF position, disconnect power to battery charger, and remove battery cables (remove negative lead first and reconnect it last) to disable generator set before working on any equipment connected to generator. The generator set can be started by automatic transfer switch or remote start/stop switch unless these precautions are followed.

# Hazardous Voltage/Electrical Shock

<b>⚠ WARNING</b>	
	
<b>Hazardous voltage.</b>	<b>Moving rotor.</b>
<b>Can cause severe injury or death.</b>	
Do not operate generator set without all guards and electrical enclosures in place.	

**Hazardous voltage can cause severe injury or death.** De-energize both normal and emergency power sources before proceeding. Move generator master switch on controller to OFF position and disconnect battery negative (-) before working on transfer switch! Turn the transfer switch selector switch to the OFF position.

**Hazardous voltage can cause severe injury or death.** Keep everyone away from the set and take precautions to prevent unqualified personnel from tampering. Have the set and electrical circuits serviced only by qualified technicians. Wiring should be inspected at the recommended interval shown in the service schedule—replace leads that are frayed or in poor condition. Do not operate electrical equipment when standing in water, on wet ground, or when your hands are wet.

**Hazardous voltage can cause severe injury or death.** Electrical shock may occur if battery charger is not properly grounded. Connect battery charger enclosure to ground of a permanent wiring system. As an alternative, run an equipment-grounding conductor with circuit conductors and connect to equipment-grounding terminal or lead on battery charger. Battery charger installation should be performed as prescribed in equipment manual and must comply with all local codes and ordinances.

*(Applies to Optional Battery Charger.)*

**Hazardous voltage can cause severe injury or death.** Improper reconnection may damage charger and battery(ies), and create an electrical shock hazard. Installation must be done by a qualified electrician.

*(Applies to Optional Battery Charger.)*

**Hazardous voltage can cause severe injury or death.** Short circuits can cause bodily injury and/or equipment damage. Do not contact electrical connections with tools or jewelry while adjustments are made. Remove wristwatch, rings, and jewelry that can cause short circuits.

# Battery

---

 **WARNING**

**Sulfuric acid in batteries.  
Can cause severe injury or death.**

Use protective goggles and clothes. Can cause permanent damage to eyes, burn skin, and eat holes in clothing.

---

**Sulfuric acid in batteries can cause severe injury or death.** Sulfuric acid in battery can cause permanent damage to eyes, burn skin, and eat holes in clothing. Always wear splash-proof safety goggles when working around the battery. If battery electrolyte is splashed in the eyes or on skin, immediately flush the affected area for 15 minutes with large quantities of clean water. In the case of eye contact, seek immediate medical aid. Never add acid to a battery once the battery has been placed in service. Doing so may result in hazardous spattering of electrolyte.

**Explosion can cause severe injury or death.** Battery gases can cause an explosion. Do not smoke or permit flame or spark to occur near a battery at any time, particularly when it is being charged. Avoid contacting terminals with tools, etc. to prevent burns and to prevent sparks that could cause an explosion. Remove wristwatch, rings, and any other jewelry before handling battery. Never connect negative (-) battery cable to positive (+) connection terminal of starter solenoid. Do not test battery condition by shorting terminals together or sparks could ignite battery gases or fuel vapors. Any compartment containing batteries must be well ventilated to prevent accumulation of explosive gases. To avoid sparks, do not disturb battery charger connections while battery is being charged and always turn charger off before disconnecting battery connections. When disconnecting battery, remove negative lead first and reconnect it last.

## NOTES

### NOTE

Charge only LEAD-ACID or NICKEL-CADMIUM batteries with battery charger.

### NOTE

Split lock washers may be supplied with some kits. If split lock washers are supplied with kit, their use is optional.

*(use with kits only)*

### NOTE

**HARDWARE DAMAGE!** Engine and generator may make use of both American Standard and metric hardware. Be sure to use the correct size tools to prevent rounding of bolt heads and nuts.

# Introduction

This TT includes the following kits:

PA-320741 through PA-320764 and  
PA-320741-SD through PA-320764-SD

This manual contains important safety and operating instructions for automatic 2-amp battery chargers. Before using the battery charger, read all instructions and cautionary instructions on (1) battery charger, (2) battery, and (3) product using battery. Keep these instructions in mind when operating the battery charger.

The battery chargers are designed for various AC voltage, 50- or 60-Hz input, and capable of charging as follows:

**12-Volt Charger**    Lead-Acid Battery (6-cell)

**24-Volt Charger**    Lead-Acid Battery (12-cell)

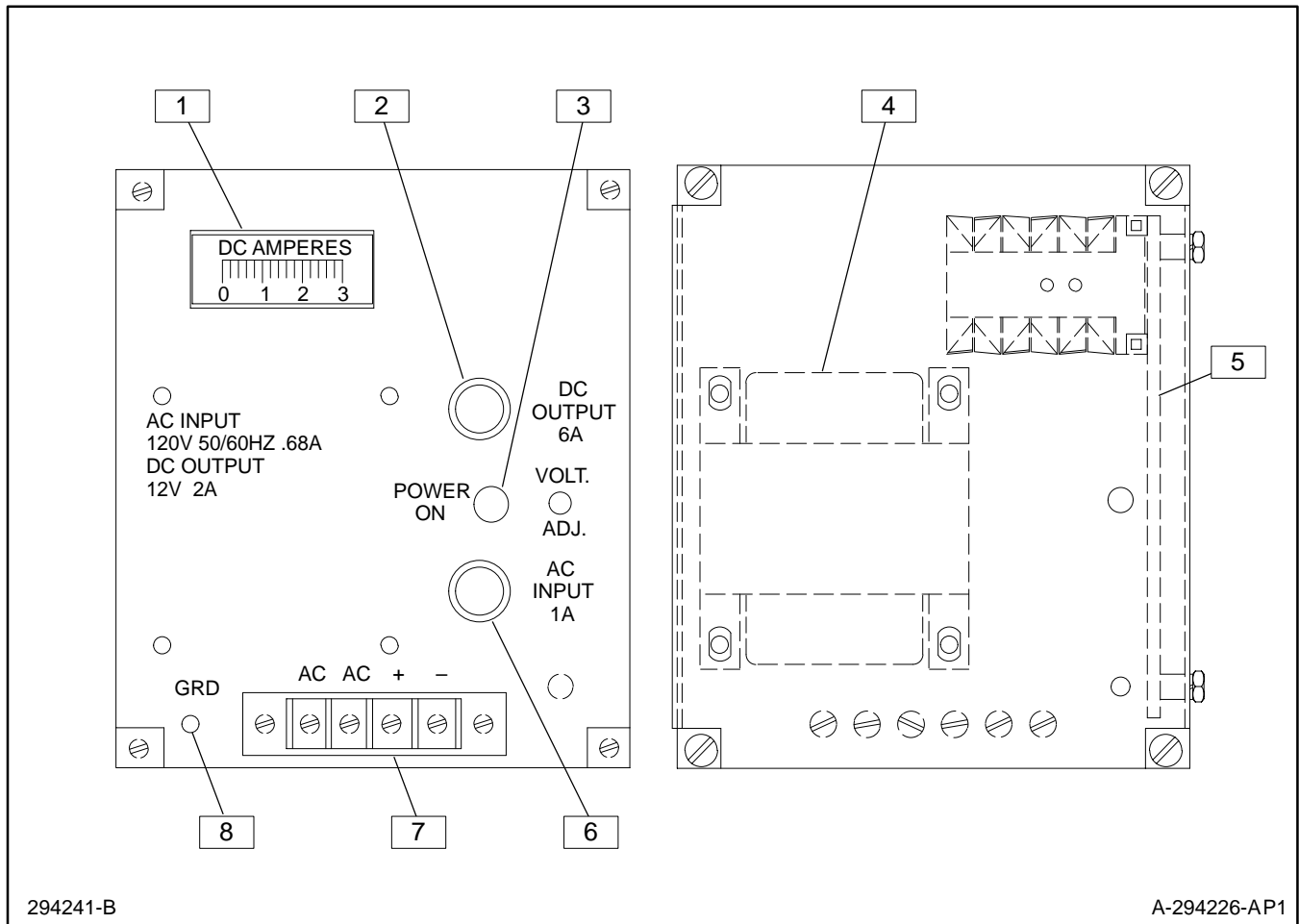
Determine input voltage and type of battery(ies) to be charged. Make any necessary modifications before using charger.

**Grounding Instructions**—Connect the battery charger to a grounded, metal, permanent wiring system or an equipment-grounding conductor with circuit conductors and connect it to equipment-grounding terminal or lead on battery charger. Connections to battery charger should comply with all local codes and ordinances.

# Specifications

The automatic battery charger is designed to charge and maintain lead-acid and nickel-cadmium automotive-type batteries in a fully charged state without any manual intervention. The charger output provided by the power transformer is controlled by the circuit board. The control board provides the charger with current-limiting, AC line compensation, reverse-polarity protection, ambient-temperature compensation, and constant voltage charging mode.

The control circuit board continuously monitors the battery and load conditions to maintain the battery's proper state of charge. Refer to Figure 1 for component identification. The chargers are factory adjusted to maintain the battery at the proper float voltages. The 12-volt charger will maintain a lead-acid (6-cell) battery with no adjustment required. The 24-volt charger will maintain a lead-acid (12-cell) battery with no adjustment required.



1. DC Ammeter
2. DC Output Fuse
3. "Power On" Lamp
4. Transformer

5. Main Circuit Board Assembly
6. AC Input Fuse
7. Terminal Block
8. Ground Terminal (AC)

**Figure 1. Battery Charger Components**

# Battery Charger Kits Selection Table

Descriptions	Loose	Installed	Volts		Input Voltage					
			12	24	120 V 50/60 Hz	240 V 50/60 Hz	220 V 50/60 Hz	480/600 V 50/60 Hz	208 V 50/60 Hz	380/416 V 50/60 Hz
			Transfer Switch Accessory No.		X	X		KA-24-62A	KA-24-64A	KA-24-63A
Battery Charger Kit No. *	X		X		PA-320741	PA-320747	PA-320745	PA-320751	PA-320743	PA-320749
Transfer Switch Accessory No.		X		X	KA-24-62B	KA-24-64B	KA-24-63B	KA-24-60B	KA-24-68B	KA-24-71B
Battery Charger Kit No. *	X			X	PA-320742	PA-320748	PA-320746	PA-320752	PA-320744	PA-320750

\* SATS model transfer switches have an -SD suffix. EXAMPLE: PA-320741-SD

**Figure 2. Battery Chargers for S340 Model Transfer Switch**

Descriptions	Loose	Installed	Volts		Input Voltage					
			12	24	120 V 50/60 Hz	240 V 50/60 Hz	220 V 50/60 Hz	480/600 V 50/60 Hz	208 V 50/60 Hz	380/416 V 50/60 Hz
			Transfer Switch Accessory No.		X	X		DA-24-62A	DA-24-64A	DA-24-63A
Battery Charger Kit No. *	X		X		PA-320741	PA-320747	PA-320745	PA-320751	PA-320743	PA-320749
Transfer Switch Accessory No.		X		X	DA-24-62B	DA-24-64B	DA-24-63B	DA-24-60B	DA-24-68B	DA-24-71B
Battery Charger Kit No. *	X			X	PA-320742	PA-320748	PA-320746	PA-320752	PA-320744	PA-320750

\* SATS+ model transfer switches have an -SD suffix. EXAMPLE: PA-320741-SD

**Figure 3. Battery Chargers for S340+ Model Transfer Switch**

Descriptions	Loose	Installed	Volts		Input Voltage					
			12	24	120 V 50/60 Hz	240 V 50/60 Hz	220 V 50/60 Hz	480/600 V 50/60 Hz	208 V 50/60 Hz	380/416 V 50/60 Hz
			Transfer Switch Accessory No.		X	X		KD-24-62A	KD-24-64A	KD-24-63A
Battery Charger Kit No. *	X		X		PA-320753	PA-320759	PA-320757	PA-320763	PA-320755	PA-320755
Transfer Switch Accessory No.		X		X	KD-24-62B	KD-24-64B	KD-24-63B	KD-24-60B	KD-24-68B	KD-24-71B
Battery Charger Kit No. *	X			X	PA-320754	PA-320760	PA-320758	PA-320764	PA-320756	PA-320756

\* MATS model transfer switches have an -SD suffix. EXAMPLE: PA-320741-SD

**Figure 4. Battery Chargers for M340 Model Transfer Switch**



Descriptions	Loose	Installed	Volts		Input Voltage					
			12	24	120 V 50/60 Hz	240 V 50/60 Hz	220 V 50/60 Hz	480/600 V 50/60 Hz	208 V 50/60 Hz	380/416 V 50/60 Hz
			Transfer Switch Accessory No.	X	X	X		DD-24-62A	DD-24-64A	DD-24-63A
Battery Charger Kit No. *	X		X		PA-320753	PA-320759	PA-320757	PA-320763	PA-320755	PA-320761
Transfer Switch Accessory No.		X		X	DD-24-62B	DD-24-64B	DD-24-63B	DD-24-60B	DD-24-68B	DD-24-71B
Battery Charger Kit No. *	X			X	PA-320754	PA-320760	PA-320758	PA-320764	PA-320756	PA-320762

\* MATS+ model transfer switches have an -SD suffix. EXAMPLE: PA-320741-SD

**Figure 5. Battery Chargers for M340+ Model Transfer Switch**

Descriptions	Loose	Installed	Volts		Input Voltage					
			12	24	120 V 50/60 Hz	240 V 50/60 Hz	220 V 50/60 Hz	480/600 V 50/60 Hz	208 V 50/60 Hz	380/416 V 50/60 Hz
			Transfer Switch Accessory No.		X	X		—	KD-24-64A	KD-24-63A
Battery Charger Kit No.	X		X		—	—	—	—	—	—
Transfer Switch Accessory No.		X		X	—	KD-24-64B	KD-24-63B	—	—	—
Battery Charger Kit No.	X			X	—	—	—	—	—	—

**Figure 6. Battery Chargers for R33 Model Transfer Switch**

Descriptions	Input Voltage					
	120 V 50/60 Hz	240 V 50/60 Hz	220 V 50/60 Hz	480/600 V 50/60 Hz	208 V 50/60 Hz	380/416 V 50/60 Hz
<b>Primary Circuit Protection</b>	1 Amp 12 V 1.5 Amp 24 V	0.5 Amp 12 V 1 Amp 24 V	0.5 Amp 12 V 1 Amp 24 V	0.2 Amp 12 V 0.4 Amp 24 V	0.5 Amp 12 V 1 Amp 24 V	0.3 Amp 12 V 0.5 Amp 24 V
<b>Secondary Circuit Protection</b>	6 Amp Slo-Blo					
<b>Output Level Preset at Factory</b>	12-Volt Charger—13.2 Volt, 2 Amp Current Limiting 24- Volt Charger—26.4 Volt, 2 Amp Current Limiting					

**Figure 7. Battery Charger Specifications**

# Installing Charger

---

 **WARNING**



**Sulfuric acid in batteries.  
Can cause severe injury or death.**

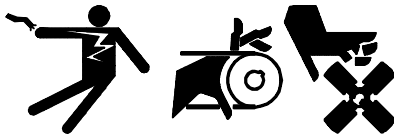
Use protective goggles and clothes. Can cause permanent damage to eyes, burn skin, and eat holes in clothing.

---

**Sulfuric acid in batteries can cause severe injury or death.** Sulfuric acid in battery can cause permanent damage to eyes, burn skin, and eat holes in clothing. Always wear splash-proof safety goggles when working around the battery. If battery electrolyte is splashed in the eyes or on skin, immediately flush the affected area for 15 minutes with large quantities of clean water. In the case of eye contact, seek immediate medical aid. Never add acid to a battery once the battery has been placed in service. Doing so may result in hazardous spattering of electrolyte.

---

 **WARNING**



**Accidental starting.  
Can cause severe injury or death.**

Disconnect battery cables before working on generator set (negative lead first and reconnect it last).

---

**Accidental starting can cause severe injury or death.** Turn generator master switch to OFF position, disconnect power to battery charger, and remove battery cables (remove negative lead first and reconnect it last) to disable generator set before working on any equipment connected to generator. The generator set can be started by automatic transfer switch or remote start/stop switch unless these precautions are followed.

**NOTE**

**CHARGER DAMAGE!** Connect battery charger only to a battery with the same DC voltage as the battery charger output rating.

 **WARNING**



**Explosion.  
Can cause severe injury or death. Relays in  
battery charger cause arcs or sparks.**

Locate in a well ventilated area. Keep explosive fumes away.

**Explosion can cause severe injury or death.** Battery gases can cause an explosion. Do not smoke or permit flame or spark to occur near a battery at any time, particularly when it is being charged. Avoid contacting terminals with tools, etc. to prevent burns and to prevent sparks that could cause an explosion. Remove wristwatch, rings, and any other jewelry before handling battery. Never connect negative (-) battery cable to positive (+) connection terminal of starter solenoid. Do not test battery condition by shorting terminals together or sparks could ignite battery gases or fuel vapors. Any compartment containing batteries must be well ventilated to prevent accumulation of explosive gases. To avoid sparks, do not disturb battery charger connections while battery is being charged and always turn charger off before disconnecting battery connections. When disconnecting battery, remove negative lead first and reconnect it last.

# Mount Charger

1. Move generator master switch to OFF position. Disconnect battery cables, negative lead first. Open circuit breaker of AC power source to be applied.
2. Turn automatic transfer switch selector to OFF position.
3. Open automatic transfer switch enclosure.
4. Install four captive nuts (298811) in the transfer switch inner panel and install battery charger. See Figure 8.
5. The battery charger is factory set to maintain the proper output for the battery voltage for which it is rated. No customer adjustments are required.

## Output Connections

### NOTE

For DC connections use stranded copper wire, 600 Volt, 105°C vinyl plastic insulation UL style 1015, CSA type TEW.

1. Due to the variety of generator installations, battery cables are not provided. To make battery connections, cut red (+) 10-gauge stranded wire to proper length and strip insulation from both ends. To one end of wire attach a post-type connector. Route other end of battery cable and connect to output positive (+) terminal on charger DC terminal block. See Figure 8. Tighten terminal block lock screw to secure battery cable. Repeat

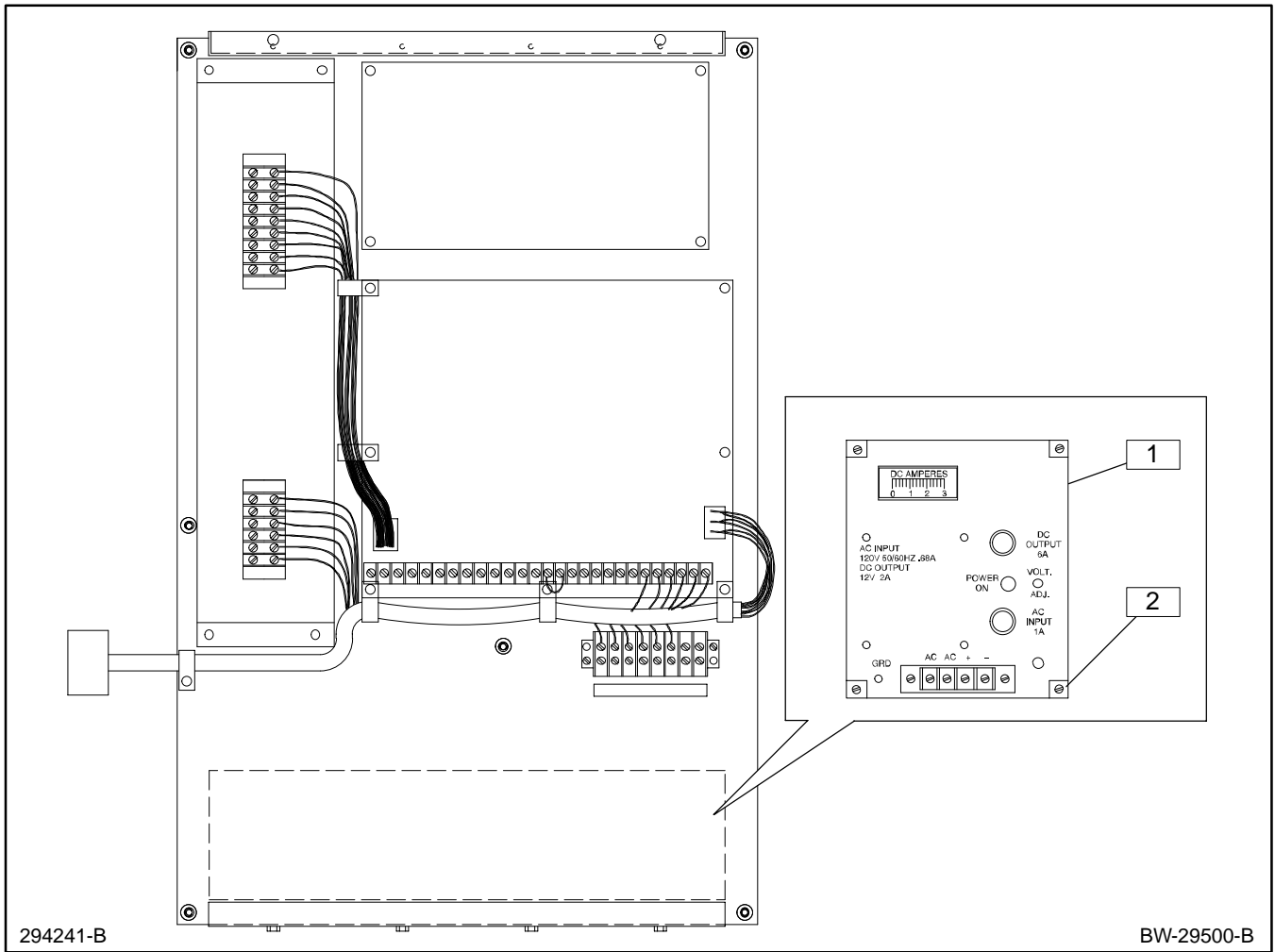
procedure with black (–) 10-gauge stranded wire; connect black wire to output negative (–) terminal on DC terminal block and secure with lock screw.

2. Connect red charger lead(s) to battery positive (+) terminal and black charger lead(s) to battery negative (–) terminal.

**Grounding Instructions**—This battery charger should be connected to a grounded, metal, permanent wiring system. An equipment-grounding conductor could also be run with circuit conductors and connected to equipment-grounding terminal on battery charger. Connections to battery charger should comply with all local codes and ordinances.

## Input Connections

1. Connect the correct voltage, 50/60 Hz, AC power source as indicated by nameplate or transfer switch wiring diagram.
2. Turn AC power on. Power On lamp will light and ammeter will show charging current.



1. Battery Charger Assembly (see parts lists)

2. Captive Nuts (298811) qty. 4

**Figure 8. Battery Charger Installation—Solid-State Transfer Switch**

# Disconnecting Charger (When Replacing or Servicing Battery)

## **WARNING**



**Explosion.**  
**Can cause severe injury or death. Relays in battery charger cause arcs or sparks.**

Locate in a well ventilated area. Keep explosive fumes away.

**Explosion can cause severe injury or death.** Battery gases can cause an explosion. Do not smoke or permit flame or spark to occur near a battery at any time, particularly when it is being charged. Avoid contacting terminals with tools, etc. to prevent burns and to prevent sparks that could cause an explosion. Remove wristwatch, rings, and any other jewelry before handling battery. Never connect negative (-) battery cable to positive (+) connection terminal of starter solenoid. Do not test battery condition by shorting terminals together or sparks could ignite battery gases or fuel vapors. Any compartment containing batteries must be well ventilated to prevent accumulation of explosive gases. To avoid sparks, do not disturb battery charger connections while battery is being charged and always turn charger off before disconnecting battery connections. When disconnecting battery, remove negative lead first and reconnect it last.

## **WARNING**

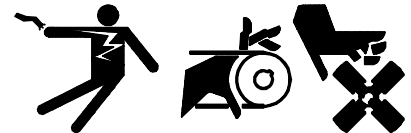
**Sulfuric acid in batteries.**  
**Can cause severe injury or death.**

Use protective goggles and clothes. Can cause permanent damage to eyes, burn skin, and eat holes in clothing.



**Sulfuric acid in batteries can cause severe injury or death.** Sulfuric acid in battery can cause permanent damage to eyes, burn skin, and eat holes in clothing. Always wear splash-proof safety goggles when working around the battery. If battery electrolyte is splashed in the eyes or on skin, immediately flush the affected area for 15 minutes with large quantities of clean water. In the case of eye contact, seek immediate medical aid. Never add acid to a battery once the battery has been placed in service. Doing so may result in hazardous spattering of electrolyte.

## **WARNING**



**Accidental starting.**

**Can cause severe injury or death.**

Disconnect battery cables before working on generator set (negative lead first and reconnect it last).

**Accidental starting can cause severe injury or death.** Turn generator master switch to OFF position, disconnect power to battery charger, and remove battery cables (remove negative lead first and reconnect it last) to disable generator set before working on any equipment connected to generator. The generator set can be started by automatic transfer switch or remote start/stop switch unless these precautions are followed.

1. Move generator master switch to OFF position.
2. Remove AC power supply from battery charger.
3. Remove charger connectors from battery, negative lead first.

# Battery Charger Operation

## Charging Lead-Acid Batteries

### WARNING

**Sulfuric acid in batteries.  
Can cause severe injury or death.**

Use protective goggles and clothes. Can cause permanent damage to eyes, burn skin, and eat holes in clothing.



**Sulfuric acid in batteries can cause severe injury or death.** Sulfuric acid in battery can cause permanent damage to eyes, burn skin, and eat holes in clothing. Always wear splash-proof safety goggles when working around the battery. If battery electrolyte is splashed in the eyes or on skin, immediately flush the affected area for 15 minutes with large quantities of clean water. In the case of eye contact, seek immediate medical aid. Never add acid to a battery once the battery has been placed in service. Doing so may result in hazardous spattering of electrolyte.

### WARNING



**Hazardous voltage.**

**Can cause severe injury or death.**

Do not operate generator set without all guards and electrical enclosures in place.



**Moving rotor.**

**Hazardous voltage can cause severe injury or death.** Electrical shock may occur if battery charger is not properly grounded. Connect battery charger enclosure to ground of a permanent wiring system. As an alternative, run an equipment-grounding conductor with circuit conductors and connect to equipment-grounding terminal or lead on battery charger. Battery charger installation should be performed as prescribed in equipment manual and must comply with all local codes and ordinances.

*(Applies to Optional Battery Charger.)*

### WARNING



**Explosion.**

**Can cause severe injury or death. Relays in battery charger cause arcs or sparks.**

Locate in a well ventilated area. Keep explosive fumes away.

**Explosion can cause severe injury or death.** Battery gases can cause an explosion. Do not smoke or permit flame or spark to occur near a battery at any time, particularly when it is being charged. Avoid contacting terminals with tools, etc. to prevent burns and to prevent sparks that could cause an explosion. Remove wristwatch, rings, and any other jewelry before handling battery. Never connect negative (-) battery cable to positive (+) connection terminal of starter solenoid. Do not test battery condition by shorting terminals together or sparks could ignite battery gases or fuel vapors. Any compartment containing batteries must be well ventilated to prevent accumulation of explosive gases. To avoid sparks, do not disturb battery charger connections while battery is being charged and always turn charger off before disconnecting battery connections. When disconnecting battery, remove negative lead first and reconnect it last.

Charge 6- or 12-cell lead-acid batteries according to the following procedure.

1. Inspect battery for defective cables, loose posts, or loose terminals. Battery terminals and battery charger clips must be tight and cleaned of all corrosion for efficient charging.
2. Check the fluid level in each cell. If fluid level is low, add distilled water until fluid is at proper level. (No maintenance is required for sealed batteries.) When using a dry-charge battery, the battery must be given a conditioning charge immediately after the electrolyte fluid has been added. An automatic charger will not operate properly on this type of battery unless it has been given a conditioning charge. Follow the battery manufacturer's recommendations for length of charge.

3. The charge rate the charger is delivering to the battery is indicated on the ammeter. The charger control circuit limits the maximum charging current to 2 amps. No cranking disconnect is required due to the current-limit protection feature. A battery is almost fully charged when one of the following occurs:

**Charging rate will taper to zero.** This occurs as a battery becomes charged and the battery voltage approaches the control voltage setting. The ammeter needle may fluctuate, indicating a continuous supply of pulsating current that automatically keeps the battery in a charged condition.

**Specific gravity reading (using a hydrometer) should be between 1.250 and 1.285 at an electrolyte temperature of 80°F (26.7°C).** This hydrometer reading indicates a battery that is in good condition.

**Bubbles appear at the surface of the battery fluid.** This indicates a battery that is 80 to 85% charged. Vigorous bubbling occurs when the battery is near full charge.

- As a battery becomes charged and the battery voltage approaches the control voltage setting, the charging rate will taper to zero. The ammeter needle may fluctuate, indicating a continuous supply of pulsating current that automatically keeps the battery in a charged condition.
- A battery in good condition should have a specific gravity reading (using a hydrometer) between 1.250 and 1.285 at an electrolyte temperature of 80°F (26.7°C). See "Checking Specific Gravity."
- When a battery reaches 80-85% of full charge, bubbles appear on the surface of fluid. Vigorous bubbling occurs when the battery is near full charge.

# Checking Specific Gravity (Lead-Acid Batteries)

Use a battery hydrometer to check the specific gravity of the electrolyte in each battery cell. While holding the hydrometer vertically, read the number on the glass bulb at the top of the electrolyte level. The battery is fully charged if the specific gravity is 1.260 at an electrolyte temperature of 80°F (26.7°C). The difference between specific gravities of each cell should not exceed 0.01. The battery should be charged if the specific gravity is below 1.215 at an electrolyte temperature of 80°F (26.7°C). **The temperature of the battery electrolyte will affect the specific gravity reading and must be taken into consideration when checking battery specific gravity. If the hydrometer used does not have a temperature correction table, use the one shown in Figure 9.**

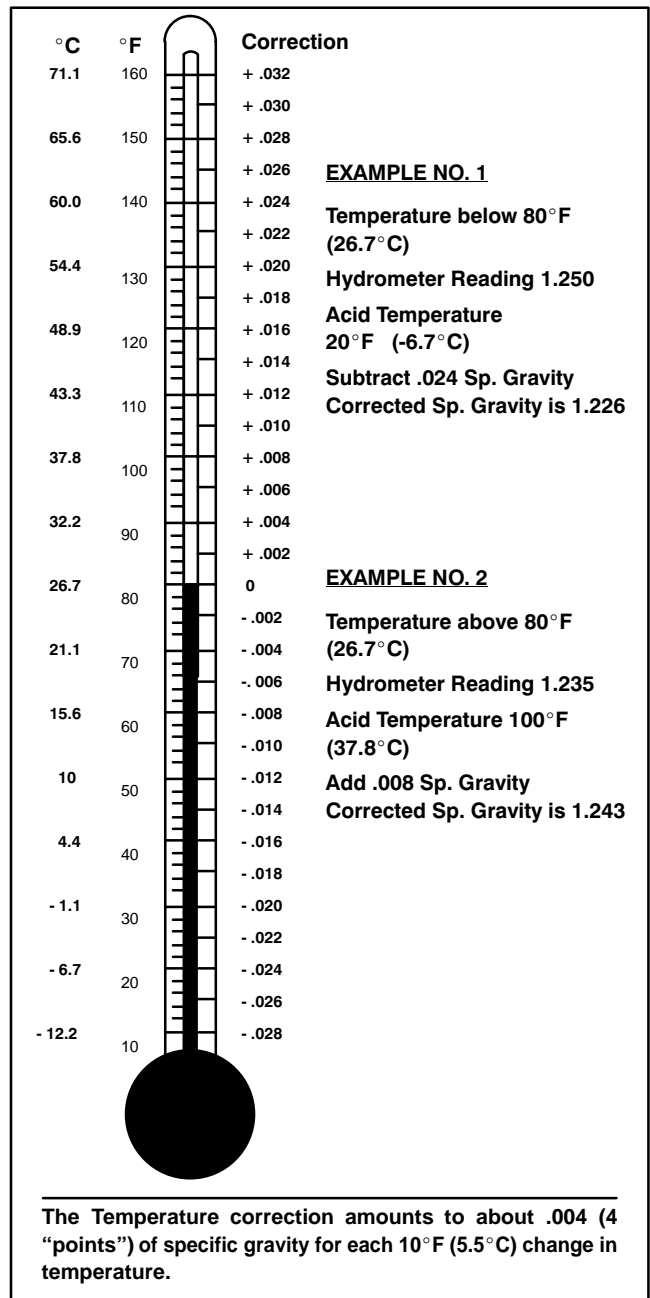


Figure 9. Specific Gravity Temperature Correction

## Charging Nickel-Cadmium Batteries

Since charging recommendations vary between manufacturers of nickel-cadmium batteries, specific nickel-cadmium battery charging instructions are not provided in this manual. Contact the manufacturer of the nickel-cadmium battery for specific charging and

maintenance instructions. If the voltage setting recommended by the battery manufacturer is different from the battery charger's factory setting, call battery charger manufacturer for the procedure for properly adjusting the battery charger.






# Charger Voltage Adjustment

The battery charger's output settings are factory set and normally require no customer adjustment. If adjustment is required, contact an authorized distributor for service or service literature. The factory settings are listed below.

Factory Output Settings		
Charger Voltage	Float Voltage	Current Limit
12 V	13.2 V	2 A
24 V	26.4 V	2 A

## Charger and Battery Maintenance

 <b>WARNING</b>	
 <b>Hazardous voltage.</b> <b>Can cause severe injury or death.</b>	 <b>Moving rotor.</b> <b>Can cause severe injury or death.</b>
Do not operate generator set without all guards and electrical enclosures in place.	

**Hazardous voltage can cause severe injury or death.** Electrical shock may occur if battery charger is not properly grounded. Connect battery charger enclosure to ground of a permanent wiring system. As an alternative, run an equipment-grounding conductor with circuit conductors and connect to equipment-grounding terminal or lead on battery charger. Battery charger installation should be performed as prescribed in equipment manual and must comply with all local codes and ordinances.

*(Applies to Optional Battery Charger.)*

**Hazardous voltage can cause severe injury or death.** Improper reconnection may damage charger and battery(ies), and create an electrical shock hazard. Installation must be done by a qualified electrician.

*(Applies to Optional Battery Charger.)*

**Hazardous voltage can cause severe injury or death.** Short circuits can cause bodily injury and/or equipment damage. Do not contact electrical connections with tools or jewelry while adjustments are made. Remove wristwatch, rings, and jewelry that can cause short circuits.

### **WARNING**

**Sulfuric acid in batteries.**  
**Can cause severe injury or death.**



Use protective goggles and clothes. Can cause permanent damage to eyes, burn skin, and eat holes in clothing.

**Sulfuric acid in batteries can cause severe injury or death.** Sulfuric acid in battery can cause permanent damage to eyes, burn skin, and eat holes in clothing. Always wear splash-proof safety goggles when working around the battery. If battery electrolyte is splashed in the eyes or on skin, immediately flush the affected area for 15 minutes with large quantities of clean water. In the case of eye contact, seek immediate medical aid. Never add acid to a battery once the battery has been placed in service. Doing so may result in hazardous spattering of electrolyte.

### **NOTE**

Warranty repairs must be made through an authorized dealer.

1. Check battery terminals and charger connectors for clean contact surfaces. Clean battery terminals and charger connectors as necessary with a mild baking soda/water solution. If battery charger does not work, see Troubleshooting section.
2. Check battery fluid level regularly; maintain battery fluid at proper level.

# Troubleshooting

Problem	Remedy
<b>No Ammeter Reading</b>	<ol style="list-style-type: none"><li>1. Check charger connections to battery for correct polarity.</li><li>2. Turn off AC supply prior to rechecking the battery charger for clean, tight connections.</li><li>3. Check for AC at the charger terminal strip.</li><li>4. Check AC input and DC output fuses.</li><li>5. Check secondary voltage at transformer: 24 volts across secondary, with 12 volts to center tap.</li><li>6. With AC supply disconnected, check DC output lead connections from circuit board to DC output terminal block.</li></ol>
<b>Needle Remains at 2 Amps Indefinitely</b>	<ol style="list-style-type: none"><li>1. Battery charger not matched to battery voltage.</li><li>2. Battery may be severely discharged or have shorted cells.</li></ol>

# Standard Accessories

## Current Limiting

The charger is protected from overload by its current-limiting circuitry. This circuitry continuously monitors the charger output current and is set to limit the

current to 2 amps from full load to short circuit. Therefore, no crank disconnect is required when the plant is exercised.

## Reverse Polarity Protection

When the charger is connected to the battery, the reverse polarity protection circuit determines if the connection is of the proper polarity. If the polarity is

incorrect, the charger will not turn on when AC input is connected.

## Automatic Float Operation

When the charger is properly connected to the battery and AC power is applied to the charger, the charger operates in the constant-current mode until the battery voltage rises to the preset float level. At the preset float level, the charger will switch to the constant-voltage

float mode. The charger will operate in constant-voltage float mode until AC input power is lost or the current required to maintain the battery at the float voltage setting exceeds 2 amps.

## Temperature Compensation

The charger will provide temperature compensation of  $-2 \text{ mV}/^\circ\text{C}$  per cell over the ambient temperature range of  $-40^\circ\text{C}$  ( $-40^\circ\text{F}$ ) to  $+60^\circ\text{C}$  ( $+140^\circ\text{F}$ ). This feature will automatically adjust the float voltage setting to prevent

the battery from being overcharged at high ambient temperatures and undercharged at low ambient temperatures.

## AC Input Fuse

When AC input is applied, the AC input fuse will open to protect the power transformer from damage due to a short circuit condition. The fuse may also open if

subjected to vibration for an extended period of time. Replace the fuse to return the charger to operation. See charts in "Specifications" section for fuse value.

## DC Output Fuse

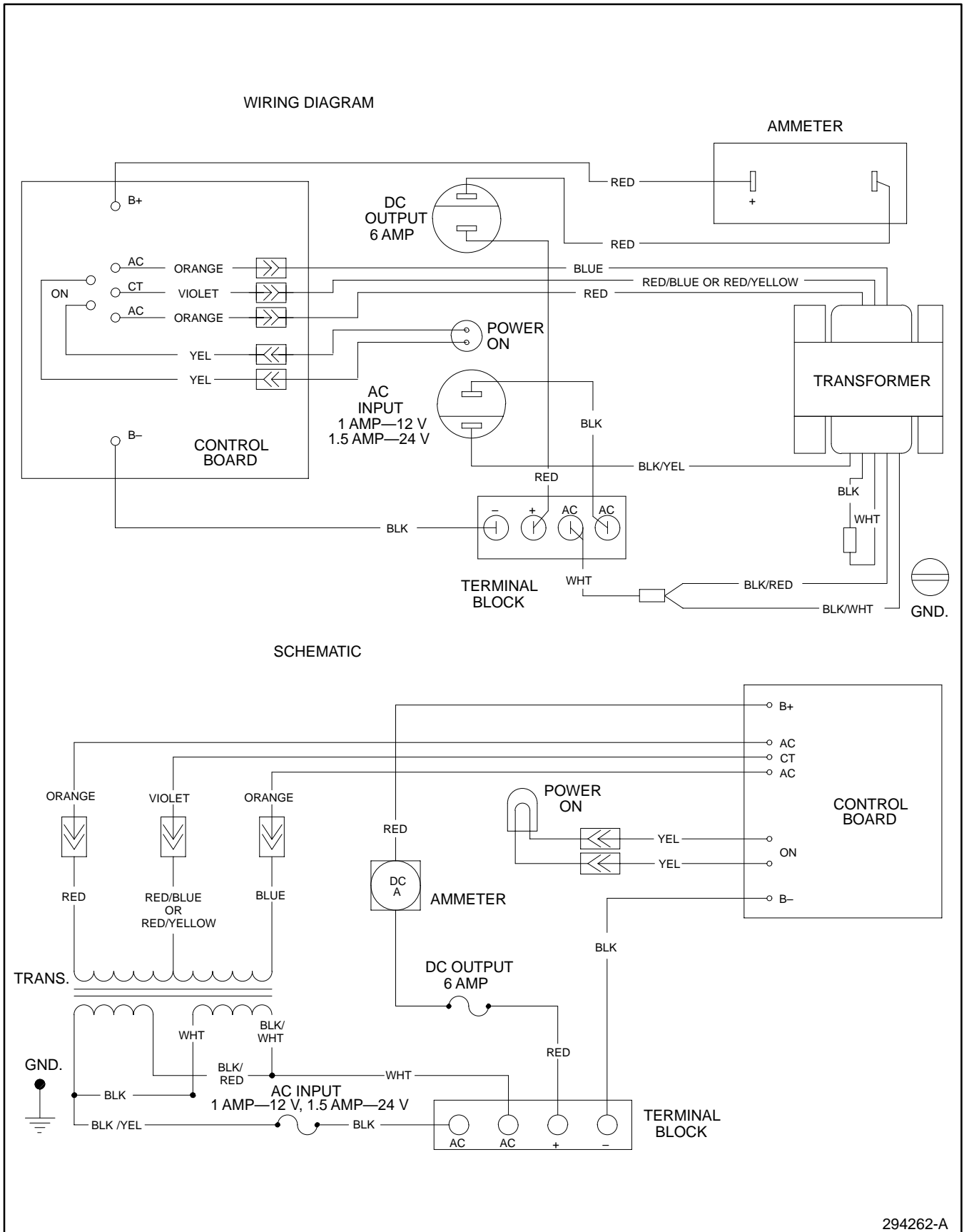
The DC output fuse will open and protect the power transformer from damage if the current limit setting has been disabled or set to its maximum. It will also open if

the charger output leads are shorted together for an extended period of time.

## Power On Lamp

The Power On lamp is connected across the power transformer's primary winding and indicates when AC power is present.

# Wiring Diagrams



294262-A

Figure 10. Wiring Diagram, Schematic—120-Volt Battery Charger

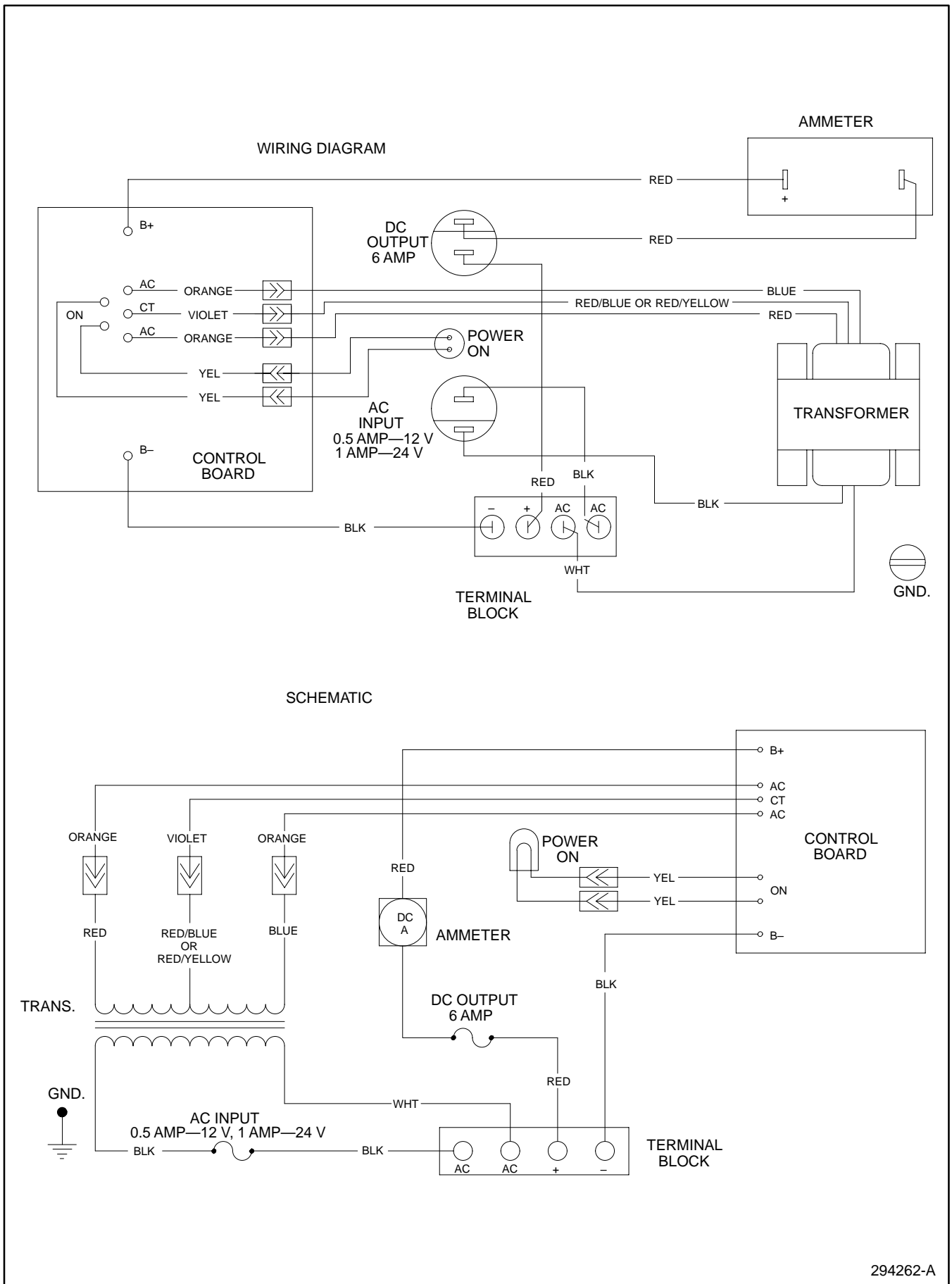
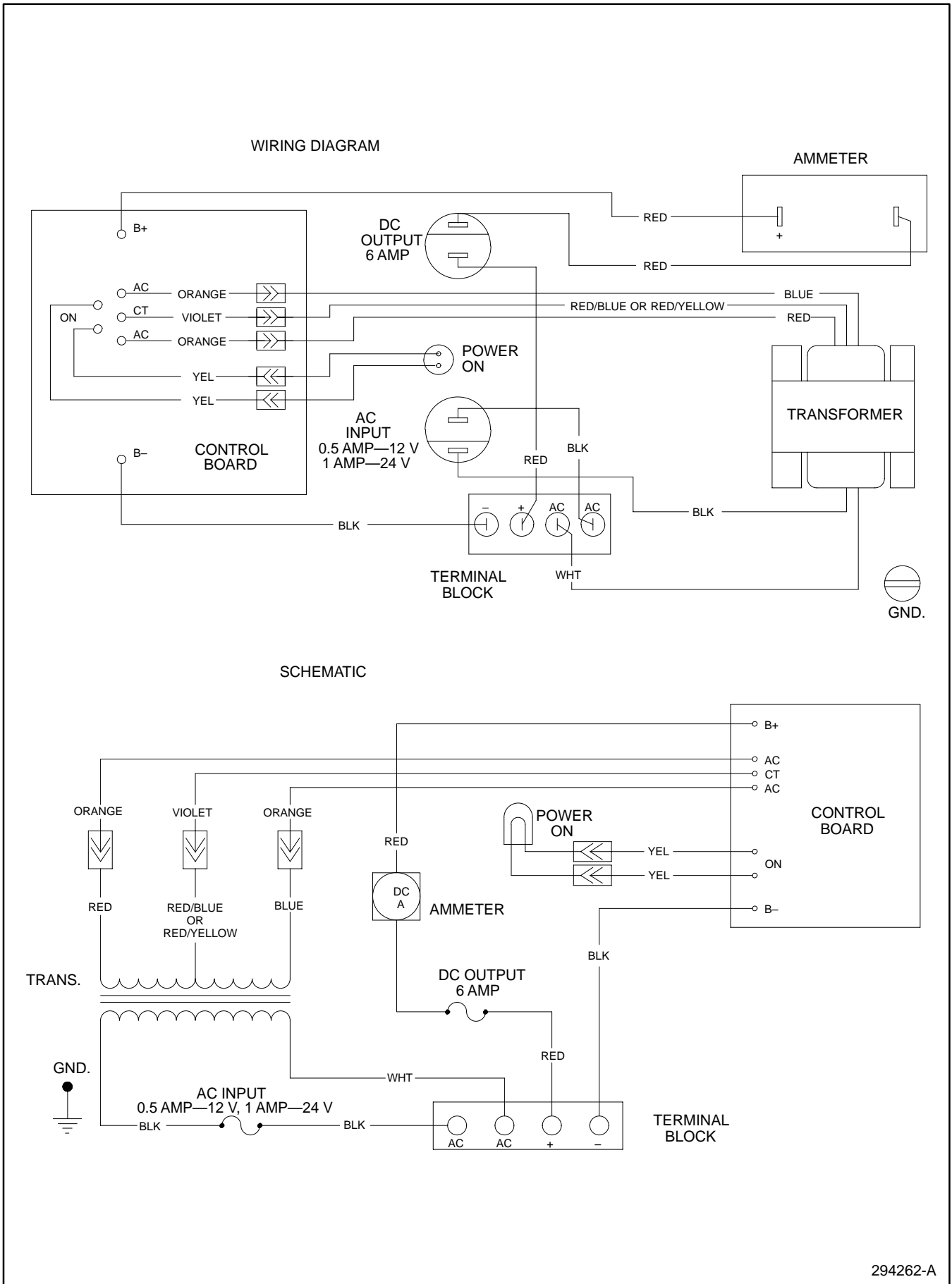
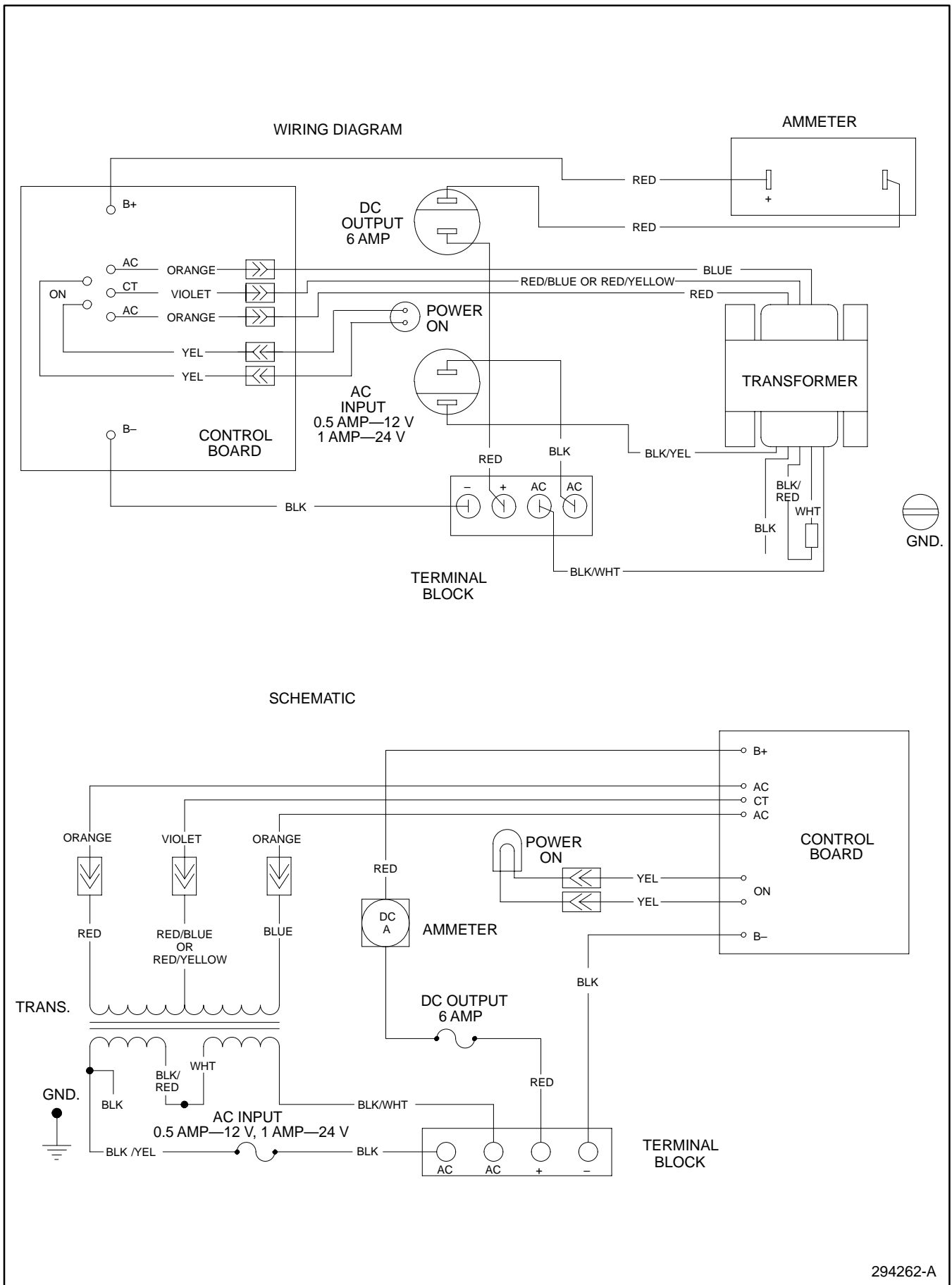


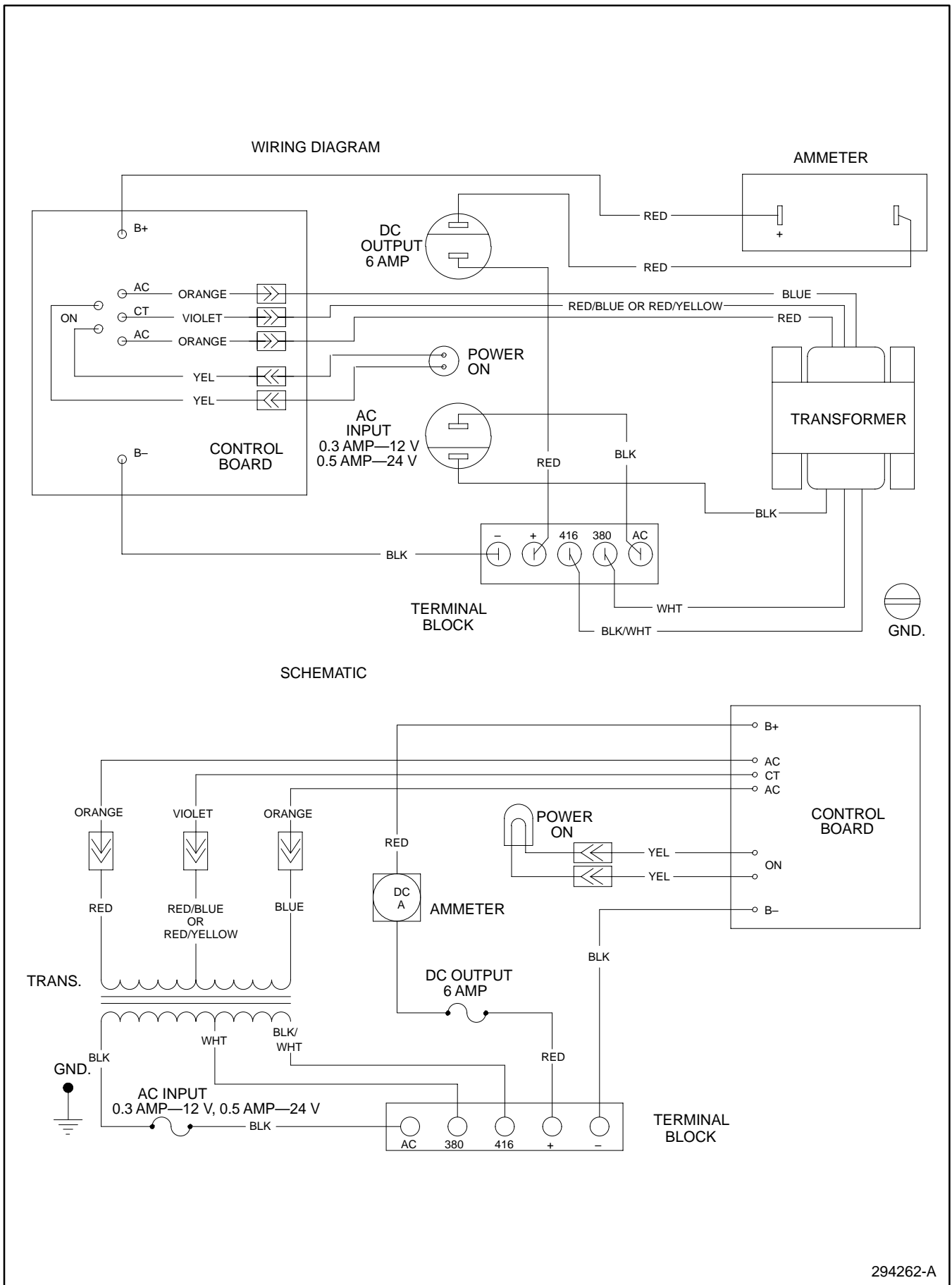
Figure 11. Wiring Diagram, Schematic—208-Volt Battery Charger



**Figure 12. Wiring Diagram, Schematic—220-Volt Battery Charger**

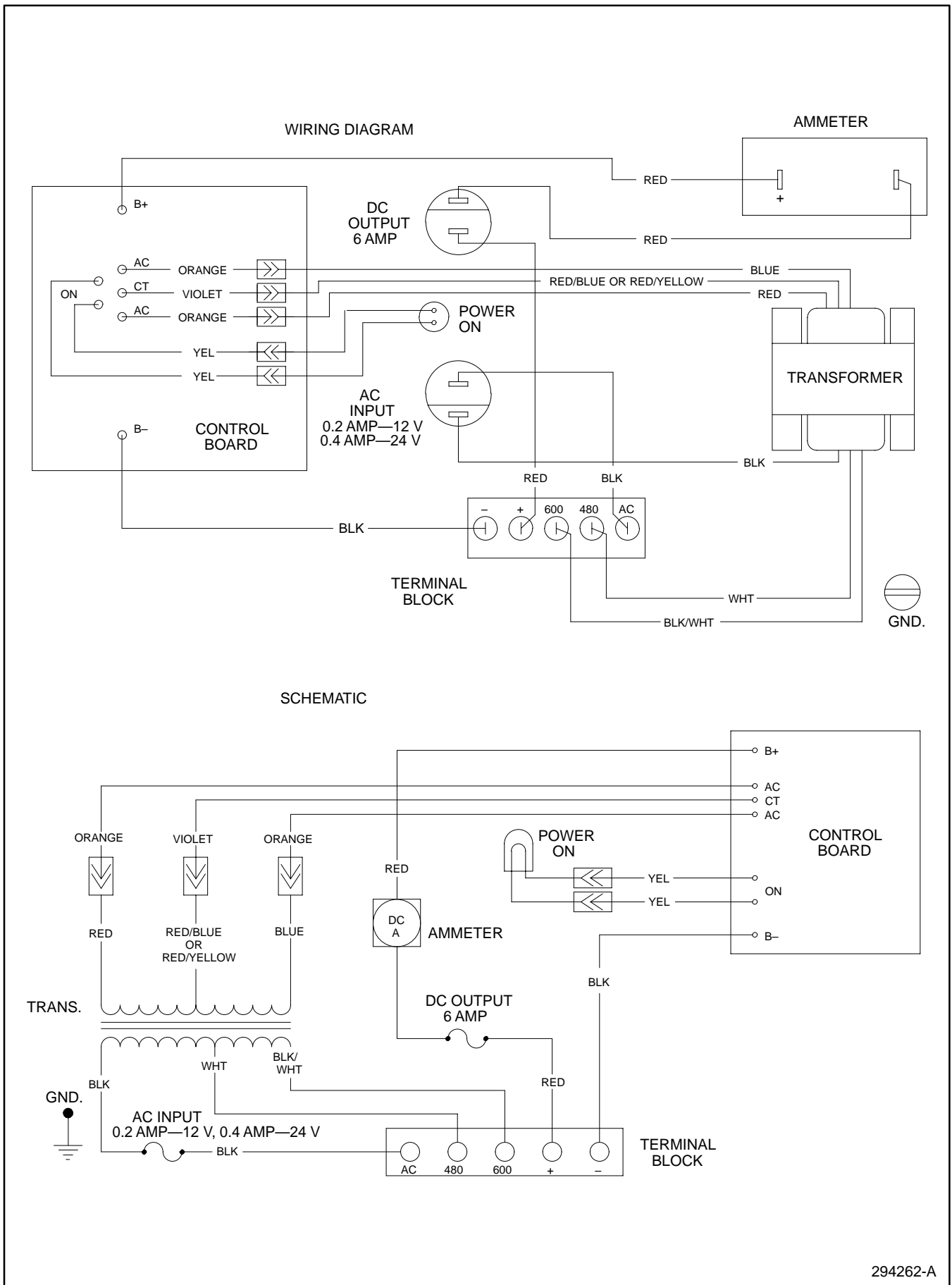


**Figure 13. Wiring Diagram, Schematic—240-Volt Battery Charger**



**Figure 14. Wiring Diagram, Schematic—380/416-Volt Battery Charger**





**Figure 15. Wiring Diagram, Schematic—480/600-Volt Battery Charger**

## Parts List

<b>Kits PA-320741 and PAB-320741-SD</b>		
<b>Description</b>	<b>Qty.</b>	<b>Part Number</b>
Charger Assembly, 120/12-volt battery (includes *)	1	A-294226
Circuit Board Assembly, 12-volt ATS battery *	1	A-294239
Lead *	1	LB-1806-15457
Lead *	1	LR-1806-5757
Lead *	1	LR-1808-15457
Lead *	1	LW-1803-15400
Washer, #6 lock *	6	X-22-6
Washer, #8 lock *	2	X-22-7
Insulink Terminal *	1	X-367-3
Insulink Terminal *	1	X-367-4
Terminal *	1	X-431-25
Terminal *	2	X-431-29
Terminal *	3	X-431-30
Screw, 6-32 x 0.875 in. *	2	X-49-3
Screw, 8-32 x 0.500 in. *	4	X-51-15
Screw, 8-32 x 0.625 in. *	1	X-51-53
Spacer, fiber *	4	X-712-13
Fuse *	1	226520
Fuse *	1	226525
Holder, fuse *	2	238426
Ammeter *	1	293278
Transformer *	1	293279
Strip, terminal *	1	293281
Lamp *	1	293655
Cover, terminal block *	1	294214
Box, silkscreen *	1	294241
Decal, barrier *	1	294742
Retainer *	4	294759
Lead	1	T078-1814-1313
Lead	1	T079-1814-1313
Nut, captive	4	298811
* Indicates parts that are included with the charger assembly.		

## Parts List

### Kits PA-320742 and PAB-320742-SD

Description	Qty.	Part Number
Charger Assembly, 120/24-volt battery (includes *)	1	A-294227
Circuit Board Assembly, 24-volt ATS battery *	1	A-294240
Lead *	1	LB-1806-15457
Lead *	1	LR-1806-5757
Lead *	1	LR-1808-15457
Lead *	1	LW-1803-15400
Washer, #6 lock *	6	X-22-6
Washer, #8 lock *	2	X-22-7
Insulink Terminal *	1	X-367-3
Insulink Terminal *	1	X-367-4
Terminal *	1	X-431-25
Terminal *	2	X-431-29
Terminal *	3	X-431-30
Screw, 6-32 x 0.875 in. *	2	X-49-3
Screw, 8-32 x 0.500 in. *	4	X-51-15
Screw, 8-32 x 0.625 in. *	1	X-51-53
Spacer, fiber *	4	X-712-13
Fuse *	1	226520
Holder, fuse *	2	238426
Fuse, 1.5 amp *	1	291207
Ammeter *	1	293278
Transformer *	1	293279
Strip, terminal *	1	293281
Lamp *	1	293655
Cover, terminal block *	1	294214
Box, silkscreen *	1	294242
Decal, barrier *	1	294742
Retainer *	4	294759
Lead	1	T078-1814-1313
Lead	1	T079-1814-1313
Nut, captive	4	298811

\* Indicates parts that are included with the charger assembly.

## Parts List

<b>Kits PA-320743 and PAB-320743-SD</b>		
<b>Description</b>	<b>Qty.</b>	<b>Part Number</b>
Charger Assembly, 208/12-volt battery (includes *)	1	A-294228
Circuit Board Assembly, 12-volt ATS battery *	1	A-294239
Lead *	1	LB-1806-15457
Lead *	1	LR-1806-15457
Lead *	1	LR-1808-5757
Washer, #6 lock *	6	X-22-6
Washer, #8 lock *	2	X-22-7
Terminal *	1	X-431-25
Terminal *	2	X-431-29
Terminal *	3	X-431-30
Terminal *	1	X-431-46
Screw, 6-32 x 0.875 in. *	2	X-49-3
Screw, 8-32 x 0.500 in. *	4	X-51-15
Screw, 8-32 x 0.625 in. *	1	X-51-53
Spacer, fiber *	4	X-712-13
Fuse *	1	226520
Fuse *	1	226521
Holder, fuse *	2	238426
Ammeter *	1	293278
Strip, terminal *	1	293281
Lamp *	1	293655
Transformer *	1	293659
Cover, terminal block *	1	294214
Box, silkscreen *	1	294243
Decal, barrier *	1	294742
Retainer *	4	294759
Lead	1	T078-1814-1313
Lead	1	T079-1814-1313
Nut, captive	4	298811
* Indicates parts that are included with the charger assembly.		

## Parts List

<b>Kits PA-320745 and PAB-320745-SD</b>		
<b>Description</b>	<b>Qty.</b>	<b>Part Number</b>
Charger Assembly, 240/12-volt battery (includes *)	1	A-294230
Circuit Board Assembly, 12-volt ATS battery *	1	A-294239
Lead *	1	LB-1806-15457
Lead *	1	LR-1806-15457
Lead *	1	LR-1808-5757
Washer, #6 lock *	6	X-22-6
Washer, #8 lock *	2	X-22-7
Terminal *	1	X-431-25
Terminal *	2	X-431-29
Terminal *	3	X-431-30
Terminal *	1	X-431-46
Screw, 6-32 x 0.875 in. *	2	X-49-3
Screw, 8-32 x 0.500 in. *	4	X-51-15
Screw, 8-32 x 0.625 in. *	1	X-51-53
Spacer, fiber *	4	X-712-13
Fuse *	1	226520
Fuse *	1	226521
Holder, fuse *	2	238426
Ammeter *	1	293278
Strip, terminal *	1	293281
Lamp *	1	293655
Cover, terminal block *	1	294214
Box, silkscreen *	1	294245
Decal, barrier *	1	294742
Retainer *	4	294759
Transformer *	1	295092
Lead	1	T078-1814-1313
Lead	1	T079-1814-1313
Nut, captive	4	298811
* Indicates parts that are included with the charger assembly.		

## Parts List

<b>Kits PA-320746 and PAB-320746-SD</b>		
<b>Description</b>	<b>Qty.</b>	<b>Part Number</b>
Charger Assembly, 220/24-volt battery (includes *)	1	A-294231
Circuit Board Assembly, 24-volt ATS battery *	1	A-294240
Lead *	1	LB-1806-15457
Lead *	1	LR-1806-15457
Lead *	1	LR-1808-5757
Washer, #6 lock *	6	X-22-6
Washer, #8 lock *	2	X-22-7
Terminal *	1	X-431-25
Terminal *	2	X-431-29
Terminal *	3	X-431-30
Terminal *	1	X-431-46
Screw, 6-32 x 0.875 in. *	2	X-49-3
Screw, 8-32 x 0.500 in. *	4	X-51-15
Screw, 8-32 x 0.625 in. *	1	X-51-53
Spacer, fiber *	4	X-712-13
Fuse *	1	226520
Fuse *	1	226525
Holder, fuse *	1	238426
Ammeter *	1	293278
Strip, terminal *	1	293281
Lamp *	1	293655
Cover, terminal block *	1	294214
Box, silkscreen *	1	294246
Decal, barrier *	1	294742
Retainer *	4	294759
Transformer *	1	295092
Lead	1	T078-1814-1313
Lead	1	T079-1814-1313
Nut, captive	4	298811
* Indicates parts that are included with the charger assembly.		

## Parts List

### Kits PA-320747 and PAB-320747-SD

Description	Qty.	Part Number
Charger Assembly, 240/12-volt battery (includes *)	1	A-294232
Circuit Board Assembly, 12-volt ATS battery *	1	A-294239
Lead *	1	LB-1806-15457
Lead *	1	LR-1806-15457
Lead *	1	LR-1808-5757
Washer, #6 lock *	6	X-22-6
Washer, #8 lock *	2	X-22-7
Insulink Terminal *	1	X-367-3
Terminal *	1	X-431-25
Terminal *	2	X-431-29
Terminal *	3	X-431-30
Terminal *	1	X-431-46
Screw, 6-32 x 0.875 in. *	2	X-49-3
Screw, 8-32 x 0.500 in. *	4	X-51-15
Screw, 8-32 x 0.625 in. *	1	X-51-53
Spacer, fiber *	4	X-712-13
Fuse *	1	226520
Fuse *	1	226521
Holder, fuse *	2	238426
Ammeter *	1	293278
Transformer *	1	293279
Strip, terminal *	1	293281
Lamp *	1	293655
Cover, terminal block *	1	294214
Box, silkscreen *	1	294247
Decal, barrier *	1	294742
Retainer *	4	294759
Lead	1	T078-1814-1313
Lead	1	T079-1814-1313
Nut, captive	4	298811
* Indicates parts that are included with the charger assembly.		

## Parts List

<b>Kits PA-320748 and PAB-320748-SD</b>		
<b>Description</b>	<b>Qty.</b>	<b>Part Number</b>
Charger Assembly, 240/24-volt battery (includes *)	1	A-294233
Circuit Board Assembly, 24-volt ATS battery *	1	A-294240
Lead *	1	LB-1806-15457
Lead *	1	LR-1806-15457
Lead *	1	LR-1808-5757
Washer, #6 lock *	6	X-22-6
Washer, #8 lock *	2	X-22-7
Insulink Terminal *	1	X-367-3
Terminal *	1	X-431-25
Terminal *	2	X-431-29
Terminal *	3	X-431-30
Terminal *	1	X-431-46
Screw, 6-32 x 0.875 in. *	2	X-49-3
Screw, 8-32 x 0.500 in. *	4	X-51-15
Screw, 8-32 x 0.625 in. *	1	X-51-53
Spacer, fiber *	4	X-712-13
Fuse *	1	226520
Fuse *	1	226525
Holder, fuse *	2	238426
Ammeter *	1	293278
Transformer *	1	293279
Strip, terminal *	1	293281
Lamp *	1	293655
Cover, terminal block *	1	294214
Box, silkscreen *	1	294248
Decal, barrier *	1	294742
Retainer *	4	294759
Lead	1	T078-1814-1313
Lead	1	T079-1814-1313
Nut, captive	4	298811
* Indicates parts that are included with the charger assembly.		



## Parts List

### Kits PA-320749 and PAB-320749-SD

Description	Qty.	Part Number
Charger Assembly, 380/416/12-volt battery (includes *)	1	A-294234
Circuit Board Assembly, 12-volt ATS battery *	1	A-294239
Lead *	1	LB-1806-15457
Lead *	1	LR-1806-15457
Lead *	1	LR-1808-5757
Washer, #6 lock *	6	X-22-6
Washer, #8 lock *	2	X-22-7
Terminal *	1	X-431-25
Terminal *	2	X-431-29
Terminal *	3	X-431-30
Terminal *	2	X-431-46
Screw, 6-32 x 0.875 in. *	2	X-49-3
Screw, 8-32 x 0.500 in. *	4	X-51-15
Screw, 8-32 x 0.625 in. *	1	X-51-53
Spacer, fiber *	4	X-712-13
Fuse *	1	226520
Fuse *	1	226526
Holder, fuse *	1	238426
Ammeter *	1	293278
Holder, fuse *	1	293652
Strip, terminal *	1	293653
Lamp *	1	293655
Cover, terminal block *	1	294215
Box, silkscreen *	1	294249
Decal, barrier *	1	294742
Retainer *	4	294759
Transformer *	1	295089
Lead	1	T078-1814-1313
Lead	1	T079-1814-1313
Nut, captive	4	298811
* Indicates parts that are included with the charger assembly.		

## Parts List

### Kits PA-320750 and PAB-320750-SD

Description	Qty.	Part Number
Charger Assembly, 380/416/24-volt battery (includes *)	1	A-294235
Circuit Board Assembly, 24-volt ATS battery *	1	A-294240
Lead *	1	LB-1806-15457
Lead *	1	LR-1806-15457
Lead *	1	LR-1808-5757
Washer, #6 lock *	6	X-22-6
Washer, #8 lock *	2	X-22-7
Terminal *	1	X-431-25
Terminal *	2	X-431-29
Terminal *	3	X-431-30
Terminal *	2	X-431-46
Screw, 6-32 x 0.875 in. *	2	X-49-3
Screw, 8-32 x 0.500 in. *	4	X-51-15
Screw, 8-32 x 0.625 in. *	1	X-51-53
Spacer, fiber *	4	X-712-13
Fuse *	1	226520
Holder, fuse *	1	238426
Ammeter *	1	293278
Holder, fuse *	1	293652
Strip, terminal *	1	293653
Lamp *	1	293655
Cover, terminal block *	1	294215
Box, silkscreen *	1	294250
Fuse *	1	294552
Decal, barrier *	1	294742
Retainer *	4	294759
Transformer *	1	295089
Lead	1	T078-1814-1313
Lead	1	T079-1814-1313
Nut, captive	4	298811
* Indicates parts that are included with the charger assembly.		

## Parts List

### Kits PA-320751 and PAB-320751-SD

Description	Qty.	Part Number
Charger Assembly, 480/600/12-volt battery (includes *)	1	A-294236
Circuit Board Assembly, 12-volt ATS battery *	1	A-294239
Lead *	1	LB-1806-15457
Lead *	1	LR-1806-15457
Lead *	1	LR-1808-5757
Washer, #6 lock *	6	X-22-6
Washer, #8 lock *	2	X-22-7
Terminal *	1	X-431-25
Terminal *	2	X-431-29
Terminal *	3	X-431-30
Terminal *	2	X-431-46
Screw, 6-32 x 0.875 in. *	2	X-49-3
Screw, 8-32 x 0.500 in. *	4	X-51-15
Screw, 8-32 x 0.625 in. *	1	X-51-53
Spacer, fiber *	4	X-712-13
Fuse *	1	226520
Fuse *	1	226527
Holder, fuse *	1	238426
Ammeter *	1	293278
Transformer *	1	293649
Holder, fuse *	1	293652
Strip, terminal *	1	293653
Lamp *	1	293655
Cover, terminal block *	1	294215
Box, silkscreen *	1	294251
Decal, barrier *	1	294742
Retainer *	4	294759
Lead	1	T078-1814-1313
Lead	1	T079-1814-1313
Nut, captive	4	298811
* Indicates parts that are included with the charger assembly.		

## Parts List

<b>Kits PA-320752 and PAB-320752-SD</b>		
<b>Description</b>	<b>Qty.</b>	<b>Part Number</b>
Charger Assembly, 480/600/24-volt battery (includes *)	1	A-294237
Circuit Board Assembly, 24-volt ATS battery *	1	A-294240
Lead *	1	LB-1806-15457
Lead *	1	LR-1806-15457
Lead *	1	LR-1808-5757
Washer, #6 lock *	6	X-22-6
Washer, #8 lock *	2	X-22-7
Terminal *	1	X-431-25
Terminal *	2	X-431-29
Terminal *	3	X-431-30
Terminal *	2	X-431-46
Screw, 6-32 x 0.875 in. *	2	X-49-3
Screw, 8-32 x 0.500 in. *	4	X-51-15
Screw, 8-32 x 0.625 in. *	1	X-51-53
Spacer, fiber *	4	X-712-13
Fuse *	1	226520
Fuse *	1	226528
Holder, fuse *	1	238426
Ammeter *	1	293278
Transformer *	1	293649
Holder, fuse *	1	293652
Strip, terminal *	1	293653
Lamp *	1	293655
Cover, terminal block *	1	294215
Box, silkscreen *	1	294252
Decal, barrier *	1	294742
Retainer *	4	294759
Lead	1	T078-1814-1313
Lead	1	T079-1814-1313
Nut, captive	4	298811
* Indicates parts that are included with the charger assembly.		

**TT-855 12/93b**

© 1993. All rights reserved.